

DESIGN **CRITERIA** AND SPECIFICATIONS
FOR U. S. NAVY HYDROFOIL SHIPS

VOLUME I

GENERAL INFORMATION

(Draft: 18 December 1980)

10-016207

HYDROFOIL DESIGN CRITERIA AND SPECIFICATIONS

GENERAL INFORMATION MANUAL

OUTLINE

1. Scope

1.1 Purpose of the Design Criteria

1.2 Criteria Applicability and Use

2. Applicable Documents

2.1 Design Criteria and Specifications for U. S. Navy Hydrofoil Ships

2.2 Other Applicable Documents

3. Requirements

3.1 Overview and Management

3.2 Weight and Center of Gravity Margins

3.2.1 Preliminary Design Weight Margins

3.2.1.1 Margins in Light Ship Weight

3.2.1.2 Margin in Full Load Weight

3.2.2 Contract Design Weight Margin

3.2.2.1 Margins in Light Ship Weight

3.2.2.2 Margin in Full Load Weight

3.2.3 Detail Design Weight Margins

3.2.3.1 Margins in Light Ship Weight

3.2.3.2 Margin in Full Load Weight

3.2.4 Center of Gravity Margins

3.3 Environment

3.3.1 Temperature, Humidity and Barometric Pressure

3.3.2 Sea State

3.3.3 Wind Speed/Direction

3.4 Static Stability

3.5 Materials and Manufacturing Technology

3.5.1 General

3.5.1.1 Material Selection

3.5.1.2 Standardization

3.5.2 Metallic Materials

3.5.2.1 Procurement Specifications

3.5.2.2 Mechanical and Physical Properties

3.5.2.3 Processing

3.5.2.4 Limitations

3.5.2.4.1 Low Alloy Steels

3.5.2.4.2 Corrosion Resistant Steels

3.5.2.4.3 Aluminum Alloys

3.5.2.4.4 Titanium Alloys

3.5.2.4.5 Nickel Alloys

3.5.2.4.6 Copper Alloys

3.5.3 Non-Metallic Materials

3.5.3.1 Coatings

3.5.3.1.1 Usage

3.5.3.1.2 Life Expectancy

3.5.3.1.3 Coating Application

3.5.3.1.4 Limitations

3.5.5.3 Propulsion Components

3.5.5.3.1 Propellers

3.5.5.3.2 Waterjet Pumps

3.5.5.3.3 Water Ducts and Inlets

3.5.5.3.4 Bearings

3.5.5.4 Piping Systems

3.5.5.4.1 Hydraulic

3.5.5.4.2 Seawater Systems

3.5.5.4.3 Fresh Water

3.5.6 Material Accountability

3.6 Shock and Vibration

4. Quality Assurance

4.1 Ship Tests

4.2 Materials Tests

4.2.1 Material Inspection Plan

4.2.2 Material Property Data Generation

4.2.3 Sealant/Fairing Material Qualification

4.2.3.1 Adhesive Strength

4.2.3.2 Erosion Resistance

4.2.3.3 Impact Resistance

4.2.3.4 Flexibility

4.2.3.5 Fluid Resistance

4.2.3.6 Weathering Resistance

4.2.3.7 Shrinkage

4.2.3.8 Ease of Application

4.2.3.9 Repairability

HYDROFOIL CRITERIA

General Information Manual

OUTLINE

1.0 Scope

1.1 Purpose of the Design Criteria

1.2 Criteria Applicability and Use

2.0 Applicable Documents

2.1 Design Criteria and Specifications for U.S. Navy Hydrofoil Ships

2.2 Other Applicable Documents

3.0 Criteria

3.1 Overview and Management

3.2 Weight and Center of Gravity Margins

3.3 Environmental Criteria

3.3.1 Temperature, Humidity, and Barometric Pressure

3.3.2 Sea State

3.3.3 Wind Speed/Direction

3.4 Static Stability Criteria

3.5 Materials and Manufacturing Technology

3.6 Shock and Vibration

4.0 Quality Assurance

5.0 Preparation for Delivery

5.1 Drawings

5.2 Reporting

5.2.1 Weight Reporting

5.2.2 Ship Characteristics Data

5.2.2.1 General Characteristics Data Sheets

5.2.2.2 Detail Characteristics Data Sheets

6.0 Notes

6.1 Glossary and Abbreviations

1. SCOPE

1.1 PURPOSE OF THE DESIGN CRITERIA

The Hydrofoil Design Criteria and Specifications consist of this and thirteen other parts. They provide standardized design criteria and construction specifications for contractual purposes. These are the minimum standards needed to ensure that the safety of the ship or its ability to perform its mission in the desired environment will not be jeopardized.

These criteria document the results of the U.S. Navy Advanced Hydrofoil Development Program. They shall be used by the research, design, production, and operational communities.

These general criteria may be changed. Proposed changes with their substantiation must be submitted to the Naval Sea Systems Command. The Navy shall then issue the appropriate changes.

Section 1 of this volume describes the purpose, applicability, and organization of the design criteria. The contents of the fourteen volumes and a list of other applicable documents are given in Section 2. The third section includes generally applicable information including management, environment, stability, materials, shock and vibration, and reporting. Sections 4 and 5 discuss quality assurance measures and preparation for delivery. Section 6 includes a glossary and abbreviations.

1.2 CRITERIA APPLICABILITY AND USE

These criteria shall be applied to design and construction of U.S. Navy hydrofoils. They shall be used for new construction, original or replacement component systems, and modifications.

These criteria are only applicable to hydrofoil ships with fully-submerged, subcavitating hydrofoils.

All or part of these general criteria may be used for "contractual" purposes in a particular hydrofoil ship acquisition project. This may be accomplished by invoking all or specific sections in the Top Level Requirements (TLR), Top Level Specifications (TLS), the Ship Specification, or other program related documents. Unless stated otherwise in the invoking document, these criteria shall have precedence over all other general ship specifications or standards.

Each of the volumes follows the same general outline as shown in Table 1.2. However, some parts may omit one or more sections because they are not applicable.

Each volume of the criteria is accompanied by a volume of technical substantiation. The substantiation volume follows precisely the same detailed outline as the criteria volume.

2. APPLICABLE DOCUMENTS

2.1 DESIGN CRITERIA AND SPECIFICATIONS FOR U.S. NAVY HYDROFOIL SHIPS

- 1. General Information Manual**
- 2. Hydrodynamics and Performance Prediction Criteria (Ship Characteristics Formulation)**
- 3. Ship Dynamics and Control Systems Criteria**
- 4. Structural Design Criteria**
- 5. Propulsion Systems Criteria**
- 6. Vulnerability/Survivability Criteria**
- 7. Arrangements and Habitability Criteria**
- 8. Combat Systems Integration Criteria**
- 9. Command, Control, Communications and Navigation Systems Criteria**
- 10. Electric Power and Lighting Systems Criteria**
- 11. Auxiliary Systems Criteria**
- 12. Reliability and Maintainability Criteria**
- 13. Detail Design and Construction Specifications**
- 14. Special Requirements for Test and Evaluation of Hydrofoil Ships**

2.2 OTHER APPLICABLE DOCUMENTS

3. REQUIREMENTS

3.1 OVERVIEW AND MANAGEMENT

The criteria in this volume are applicable to several disciplines; which cross discipline boundaries. In some cases the criteria in a specific discipline may differ from those shown here. If so, the specific criteria shall rule, but only within that discipline.

Reports and drawings shall be organized in accordance with the Ship Work Breakdown Structure (SWBS) as expressed in the SWBS document NAVSEA 0900-LP-039-9010.

Report requirements in this and other volumes do not preclude reporting required by the contract or other regulations.

3.2 WEIGHT AND CENTER OF GRAVITY MARGINS

The following weight and center of gravity margins must be applied to the design and construction of hydrofoil ships. In addition, strict control over weight and center of gravity in all axes shall be maintained.

3.2.1 Preliminary Design Weight Margins

3.2.1.1 Margins in Light Ship Weight

Contract Design Margin - This margin shall be reserved for the development of design detail in the subsequent Contract Design Phase. It shall be no less than three percent (3%) of the Light Ship Subtotal throughout Preliminary Design.

Preliminary Design Margin - This margin shall be used to account for uncertainties in the Preliminary Design weights. It shall be no less than seven percent (7%) of the Light Ship Subtotal at the beginning of Preliminary Design. It shall be no less than one percent (1%) of the Light Ship Subtotal at the end of Preliminary Design. This shall convert to Government Furnished Material (GFM) Margin at commencement of Contract Design.

Service Life Margin - This margin shall account for the unidentified growth which occurs in Light Ship Weight during a ship's lifetime. This value shall remain constant throughout design. It shall be no less than four percent (4%) of the Light Ship Subtotal.

Contract Modification Margin - This margin shall be reserved for use during the Detail Design Phase. It shall account for changes which typically occur during Detail Design as a result of changing requirements. It shall be no less than one percent (1%) of the Light Ship Subtotal.

3.2.1.2 Margin in Full Load Weight

These values shall be built into the design at the outset. When they are added to the Full Load Condition, the total shall not exceed the Design Full Load Weight.

Future Growth Margin - This margin shall be reserved for depletion during the service life of the ship to account for formally controlled changes which will occur at that time. Its value shall be specified by the Chief of Naval Operations.

3. 2. 2 Contract Design Weight Margins

3. 2. 2. 1 Margins in Light Ship Weight

Contract Design Margin - This value shall be equal to that retained through Preliminary Design. It shall be no less than 1.5% of the Light Ship Subtotal at the end of Contract Design. It shall become Building Margin and Detail Design Margin during Detail Design.

GFM Margin - This margin shall be reserved for depletion during the Detail Design Phase. It shall be an allowance for error in the listed weight of Government Furnished Material. It shall be equal to the terminal value of the Preliminary Design Margin.

Service Life Margin - This value shall be the same as during Preliminary Design.

Contract Modification Margin - This value shall be the same as during Preliminary Design.

3. 2. 2. 1 Margin in Full Load Weight

Future Growth Margin - This value shall be the same as during Preliminary Design.

3. 2. 3 Detail Design Weight Margins

3. 2. 3. 1 Margins in Light Ship Weight

GFM Margin - This margin shall be depleted during the Detail Design phase.

Detail Design Margin - This margin shall account for changes in weight resulting from working drawing development, growth of Contractor Furnished Material, and errors in the Accepted Weight Estimate. It shall be no less than one percent (1%) of the Light Ship Subtotal at the beginning of Detail Design and should terminate at zero.

Building Margin - This margin shall account for differing ship building practices, omissions and errors in the working drawings, unknown mill tolerances, outfitting, details, variation between the actual ship and its curves of form and similar differences. This value shall be no less than 0.5% of the Light Ship Subtotal and shall be depleted during construction.

Contract Modification Margin - This margin shall be depleted during the Detail Design and construction phases.

Service Life Margin - This value shall be the same as during the earlier design phases.

3.2.3.2 Margin in Full Load Weight

Future Growth Margin - This margin shall be the same as during the earlier design phases.

3.2.4 Center of Gravity Margins

All margin weights to be included in the Light Ship Weight shall be assumed to be located above the Light Ship Subtotal KG (Height of the center

of gravity above the keel) by no less than the following percentages of the Light Ship Subtotal KG:

Contract Design Margin-----	Z%
Preliminary Design Margin-----	Z%
Service Life Margin-----	10%
Contract Mbd. Margin-----	10%
GFM Margin-----	2%
Detail Design Margin-----	2%
Building Margin-----	2%

All margin weights to be included in the Light Ship Weight shall be assumed to be removed from the Light Ship Subtotal Longitudinal Center of Gravity in the direction of the smaller lift foil system Their distance from the Light Ship Subtotal Longitudinal Center of gravity shall be the following percentages of the Length Between Perpendiculars:

Contract Design Margin-----	Z%
Preliminary Design Margin-----	Z%
Service Life Margin-----	10%
Contract Mbd. Margin-----	10%
GFM Margin-----	2%
Detail Design Margin-----	2%
Building Margin-----	2%

All margin weights to be included as part of the Full Loads Weights shall be assumed to be located midway between the main deck and the 0-1 Level at midships on the centerline.

3.3 ENVIRONMENT

This section describes environmental criteria which are generally applicable across disciplinary lines. These relate to the natural, external environment, not to combat-related conditions. Any criterion not defined in this volume or in the appropriate discipline volume shall be taken from MIL-STD-210B.

3.3.1 TEMPERATURE, HUMIDITY, AND BAROMETRIC PRESSURE

The ship (including all necessary equipments and its crew) shall be capable of operating in the following external conditions:

Maximum air temperature	115 F (46 C)
Minimum air temperature	0 F (-18 C)
Maximum water temperature	90 F (32 C)
Minimum water temperature	40 F (4 C)
Maximum barometric pressure	31.6 in (802 mm) Mercury
Minimum barometric pressure	28.0 in (711 mm) Mercury
Maximum relative humidity	100%
Minimum relative humidity	20%

The performance of the ship and its equipments shall be rated at the following conditions:

Air temperature	100 F (38 C)
Water temperature	85 F (29 C)
Barometric pressure	30.3 in (769 mm) Mercury
Relative humidity	90%

The ship shall be capable of taking off with the specified thrust margin in the specified sea state in the rated conditions. It must be capable of taking off in all operating conditions discussed above, in the specified sea state.

3.3.2 SEA STATE

The sea state requirements for a particular ship shall be given in the requirements. The International Ship Structures Congress modification of the Bretschneider two-parameter spectrum formulation shall be used in all designs.

3.3.3 WIND SPEED/DIRECTION

The wind speed as associated with static stability is discussed in Section 3.4 "Static Stability Criteria."

The wind speed used for performance calculations, of all types, shall be that associated with the design sea state as stipulated in the ship requirements. It shall be assumed at the most disadvantageous direction.

3.4 STATIC STABILITY

Hydrofoil ships shall meet the static intact and damaged stability criteria of "Design Data Sheet - Stability and Buoyancy of U.S. Naval Surface Ships" DDS-079-1, with the following reservations.

The ship shall satisfy the wind conditions for unlimited "ocean" service, which includes service in tropical cyclones, with foils down. If the ship is permitted to operate at sea with foils up, it shall also meet the unlimited "ocean" service requirement in this condition. It shall be required to meet the "harbor" service condition with foils up, and down.

Intact and damaged static stability shall be reported in the following weight conditions (as defined in section 5.1).

- * Full Load**
- * Minimum Operating**
- * Light Ship**

In addition, if any weight condition exists which is more severe than those conditions listed above, intact static stability shall be reported in that condition.

The Center of Lateral Resistance shall be equal to one-half of the ship draft in the foils up condition.

In the foils down condition, the Center of Lateral Resistance shall be the centroid of the underwater portion of the hull plus the struts, pods, and foils. No shadowing of one strut another no-one pod by another shall be assumed. Any section of a foil which would be "shadowed" by a pod, a strut, or another section of foil shall be assumed to be shadowed.

3.5 MATERIALS AND MANUFACTURING TECHNOLOGY

This specification contains the materials criteria that shall be used for the design and fabrication of hydrofoil structures and components. Processing and inspection criteria are included as applicable.

3.5.1 GENERAL

3.5.1.1 MATERIAL SELECTION

The selection of materials for hydrofoil usage shall be based on a comparison between the material's design engineering properties and limitations and the operational requirements for each specific application. A rationale shall be prepared documenting the selection of materials for critical applications (see Section 3.5.5). The rationale can be based on the service history of an established material under similar operating conditions, a comprehensive tradeoff study, or a combination of experience and tradeoff data. The rationale as a minimum shall compare candidate materials on the basis of:

- a) Strength-to-weight ratio**
- b) Fracture toughness and fatigue**
- c) Susceptibility to environmental degradation**
- d) Estimated system acquisition and maintenance costs**

3.5.1.2 STANDARDIZATION

Particular attention shall be given to the selection of materials and standard parts such as aluminum alloys, steels, tubing, bolts, nuts, rivets, lubricants, greases, sealing compounds, etc. to facilitate interchangeability,

stocking, and replacement in service. The number of different types, sizes, strengths, and consumable bulk maintenance materials shall be kept to a minimum (NAVSEA approved standard sizes and gauges shall be used where available and applicable. Requests for deviations from preferred sizes, standard parts or materials, or conditions thereof to facilitate design, procurement, or shop processing shall be accompanied by complete substantiating data on the benefits to be derived from such departures). Materials also shall be chosen on the basis of suitability and availability in this country in quantity, and from consideration of the additional restrictions created during a national emergency. Noncritical materials shall be used wherever practicable when performance, interchangeability, reliability, or safety will not be adversely affected, or production significantly altered.

3.5.2 METALLIC MATERIALS

3.5.2.1 PROCUREMENT SPECIFICATIONS

Metallic alloys shall be procured to the latest issue of the specifications shown in Table 3.5.1 unless specifically noted otherwise. Deviations must be approved by NAVSEA.

3.5.2.2 MECHANICAL AND PHYSICAL PROPERTIES

Design values for accepted materials shall be as shown in MIL-HDBK-5 or the specification minimums found in the Table 3.5.1 specifications. If design data are not available in MIL-HDBK-5 or the referenced specifications, or design data are required for materials not contained in this specification, they shall be generated in accordance with Section 4.2.2 of this specification and submitted for NAVSEA approval.

3.5.2.3 PROCESSING

Table 3.5.2 contains acceptable processes and specifications for metallic hydrofoil materials. Deviations or additions to the table require NAVSEA approval.

3.5.2.4 LIMITATIONS

The following limitations shall apply to the use of the following materials:

3.5.2.4.1 Low Alloy Steels

- a) **Low alloy steels require coatings for marine use. Organic coatings as specified in Section 3.5.3.1 are preferred over metallic coatings such as nickel plate or chrome plate because of the detrimental galvanic couple formed at any breaks in the plate. Aluminum or zinc plating may be used for short-term protection if approved by NAVSEA.**
- b) **The HY series steels shall not be stress relieved unless approval is obtained from NAVSEA.**
- c) **Avoid fabrication processes such as localized heating or machining operations that may cause decarburization or the formation of untempered martensite on the surfaces of 4000 series steel parts.**

TABLE 3.5.1

HYDROFOIL MATERIAL FORMS AND SPECIFICATIONS

Steels (Low Alloy)

HY-80 and HY-100

Sheet, Strip, and Plate	MIL-S-16216
Rolled Shapes	ML-S-22958
Bars	ML-S-21952
Forgings	ML-S-23009
Extrusions	ML-S-22664
Castings	ML-S-23008

HY-130

Plate	ML-S-24371
Bars and Forgings	ML-S-24512

AISI 4130

Sheet, Strip, and Plate	MIL-S-18729
Tubing	ML-T-6736
Castings	ML-S-22141

AISI 4330 Nod.

Bars and Forging Stock	ML-S-8699
------------------------	-----------

AISI 4340

Sheet, Strip, and Plate	AMS 6359
Bars and Reforging Stock	ML-S-5000
Tubing	AMS 6415

Steels (Corrosion Resistant)

17-4PH

Sheet, Strip, and Plate	ML-S-81506
Bars and Forgings	ML-C-24111
Castings	

(Investment, SHI)	AMS 5355
(Sand and Centri., SHI)	AMS 5398
(Investment, 130,000 psi prem)	AMS 5342
	AMS 5343
(Investment, 180,000 psi prem)	AMS 5344

TABLE 3.5.1 (Continued)

15-5PH

Sheet, Strip, and Plate
Bars and Forgings

AMS 5862
A M S 5 6 5 9

316t

T u b i n g

AMS 5573

22-13-5 (Nitronic 50)

Bars, Forgings, Extrusions, and Rings

AMS 5764

Aluminum Alloys

5456

Sheet and Plate H116/H117
H 3 2 3
Rod, Bar, Shapes, and Tube, extruded

QQ-A-250/20
QQ-A-250/9
QQ-A-200/7

5083

Sheet and Plate H323
Rod, Bar, Shapes, and Tube, extruded
Forgings and Forging Stock

QQ-A-250/6
QQ-A-200/4
QQ-A-367

5086

Sheet and Plate H116/H117
H323
Rod, Bar, Shapes, and Tube, extruded
Tube, drawn, seamless

QQ-A-250/19
QQ-A-250/7
QQ-A-200/5
VW T-700/5

5052

Sheet and Plate
Wire, Rod, and Bar, rolled or cold finished
Tube, drawn, seamless

QQ-A-250/8
QQ-A-225/7
VW T-700/4

6061

Sheet and Plate
Rod, Bar, Shapes, and Tube, extruded
Tube, drawn, seamless
Forgings and Forging Stock.

QQ-A-250/11
QQ-A-200/8
VW T-700/6
QQ-A-367

TABLE 3.5.1 (Continued)

5454-H34		
Plate		QQ - A - 250 / 10
H111		QQ - A - 200/6
7075		
Sheet and Plate		QQ - A - 250 / 12
Rod, Bar, Shapes, and Tube,	extruded	QQ - A - 200/11
Forgings and Forging Stock		QQ - A - 367
A356		
Castings (sand)		QQ - A - 601
		- C l a s s 3M
		QQ - A - 596
Castings (high strength)		ML - A - 21180
<u>Titanium</u>		
Ti-6Al-4V		
Sheet, Strip, and Plate (ELI)		MIL-T-9046
		Type III,
		Comp. D*
Bars and Forgings		ML-T-9047*
		AMS 4928**
Extrusions		AMS 4935**
Castings		ASTM B367-69**
Ti-6Al-1Cb-1Ta-0.8Mo		
Sheet, Strip, and Plate		ML-T-9046
		Type II,
		Comp. G
Commercially Pure		
Tubing (welded)		AMS 4941
Castings		ASTM B367-69

*Beta annealing not specified -- must be added requirement.

**Beta annealing and ELI grade not specified -- must be added requirements.

TABLE 3.5.1 (Continued)

Nickel Base Alloys-

Inconel 625

**Sheet, Strip, and Plate
Bars and Forgings
Tubing and Pipe**

**AMS 5599
AMS 5666
A S T M . 8 4 4 4**

Inconel 718

Sheet, Strip, and Plate

**AMS 5596 or
AMS 5597**

Bars and Forgings

-AMS 5 6 6 2

Tube and Pipe

. AMS 5589-90

MP35N

AMS 5758

Copper Alloys

90Cu-10Ni (CA 706) and 70Cu-30Ni (CA 715)

**Tubes, Condenser and Heat Exchanger
Tubing, Welded and Seamless**

**MIL-T-15005
ML-T-16420**

TABLE 3.5.2

FABRICATION CHARACTERISTICS AND SPECIFICATIONS

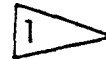

Material	Welding	Machining	Forming	Heat Treatment	Finishing
HY 80	A (6) 	A (6)	A (6)	C	A (8)
HY 100	A (6)	A (6)	A (6)	c	A (8)
HY 130	B (5)	A	A	C	A (8)
4130	B (5)	A	B (5)	A (1)	A (8)
4330	B (5)	B	B (5)	A (1)	A (8)
4340	B (5)	B	B (5)	A (1)	A (8)
17-4PH	A (5)	B	B	B (1)	B (8)
15-5PH	A (5)	B	B	B (1)	B (8)
3161	A (5)	B	A (5)	C	B (8)
22-13-5	A	B	A	C	C
21-6-9	A	B	A	C	c
5456	A (7,5)	A (4)	B (5,4)	C	A (8)
5083	A (7,5)	A (4)	B (5,4)	C	A (8)
5086	A (7,5)	A (4)	A (5,4)	C	A (8)
5052	A (7,5)	A (4)	A (5,4)	C	A (8)
6061	A (7,5)	A	A (5)	A (2)	A (8)
7075	c	A'	A (5)	A (2)	A (8)
A356	A (7,5)	A (4)	C	A (2)	A (8)
Ti-6Al-4V	B	A	A	c (3) 	c
Ti-6Al-2Cb-1Ta-1Mo	B	A	A	c (3) 	c
CP Ti	B	A	A	C (3) 	C
Inconel 625	A	B	A	c	C
Inconel 718	B	B	A	A	C
MP35N	B	B	B	B	C
90Cu-10Ni (Ch 706)	A (5)	A	A	C	C
70Cu-30Ni (CA 715)	A (5)	A	A	C	C

TABLE 3.5.2 (Continued)

NOTES:

D

Process applicability designated as follows:

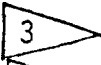
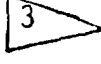
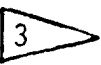
- A = Applicable Process
- B = Process Requires Special Controls
- C = Nonapplicable Process

D

Numbers in parentheses are reference specifications:

- (1) **ML-H-6875**
- (2) **ML-H-6088**
- (3) **MEL-H-81200**
- (4) **NAVSHIPS 0900-029-9010**
- (5) **NAVSHIPS 0900-006-4010**
- (6) **NAVSHIPS 0900-006-9010**
- (7) **NAVSHIPS 0900-000-1000**
- (8) **NAVSHIPS 0902-001-5000 Section 631**

3 

Stress relief only.

3.5.2.4.2 Corrosion Resistant Steels

- a) **When corrosion resistant steels are exposed to constant immersion in quiescent seawater (velocities under 4 ft/sec), they must be protected galvanically or with coatings to prevent crevice and pitting attack. In addition, any constant immersion application of the corrosion resistant steels requires a design that will control crevice attack.**

- b) **Galvanic protection more negative than -0.8 volt may cause hydrogen embrittlement of the PH steels and should be avoided.**

3.5.2.4.3 Aluminum Alloys

- a) **The 5000 series alloys (except for 5052) shall not be exposed to temperatures over 150⁰F. Any exceptions must be approved by NAVSEA. The 5052, 6061-T6, and 7075-T73 alloys shall not be exposed to temperatures over 200⁰F.**

- b) **The 7075 alloy shall be used in the T73 condition and shall not be used for welded or submerged applications.**

- c) **Aluminum hull alloys shall be coated and insulated from more noble materials such as steel and titanium when immersed in, or exposed to, seawater.**

3.5.2.4.4 Titanium Alloys

a) **When 6Al-4V titanium is called out, the extra low interstitial (ELI) or marine grades with a beta anneal shall be used for critical component applications. Standard grade or alpha-beta processed Ti-6Al-4V requires special approval by NAVSEA.**

NOTE: The available specifications do not cover beta annealing and may or may not have the ELI grade. These requirements shall be added to the purchase order as required.

b) **Avoid fabrication processes such as heat treating or welding that would result in oxygen pickup in the titanium. All surface contamination by oxygen must be removed from components prior to service.**

c) **Titanium may cause severe galvanic attack of steels and aluminum and shall be insulated from them for all marine applications. Deviations must be approved by NAVSEA.**

3.5.2.4.5 Nickel Alloys

Nickel alloys may cause severe galvanic attack of steels and aluminum and shall be insulated from them for marine applications. Deviations must be approved by NAVSEA.

3.5.2.4.6 Copper Alloys

a) **The 90-10 and 70-30 alloys shall not be used for applications where the flow velocities exceed 12 ft/sec. Deviations must be approved by NAVSEA.**

- b) Copper can cause severe corrosion of aluminum and shall be insulated from aluminum structure.

3.5.3 NONMETALLIC MATERIALS

3.5.3.1 COATINGS

3.5.3.1.1 Usage

Coatings are required for corrosion protection of alloy steels exposed to the marine environment and for aluminum hull structures when exposed to seawater or salt spray. Note: Aluminum appendages such as skegs, inlets, and pod cones may require only anodizing for adequate protection. In addition, coatings can be used for wear and cavitation/erosion resistance.

Antifoulant coatings shall be used to prevent fouling on continuously immersed components. All coating systems shall be specifically approved by NAVSEA.

3.5.3.1.2 Life Expectancy

- a) Hulls - The coating system shall protect the substrate materials from corrosion for a minimum of 5 years for interior applications and 3 years for external applications. A touch-up allowance for natural degradation of 1 percent of the surface area per year is acceptable. The minimum life of antifoulant coatings shall be 2 years.

- b) **Struts/Foil Systems** - The coating system for struts and foils (where applicable) shall protect the substrate materials from corrosion and fouling for a minimum of 500 foilborne hours. A touch-up allowance of 3 percent of the surface area is acceptable.

3.5.3.1.3 Coating Application

Coatings shall be applied per the requirements of NAVSHIPS 0902-001-5000 Section 631. Deviations require NAVSEA approval. It cannot be overemphasized that coating performance is directly related to the preparation of the substrate metal prior to the coating application.

3.5.3.1.4 Limitations

- a) The laminar X-500 aluminum-filled coating should not be used where impacts are expected.
- b) Polyurethanes such as PR 1654 are degraded by exposure to "Skydrol" hydraulic fluid or equivalent and should be protected from such exposure.

3.5.3.2 SEALANTS AND FAIRING MATERIALS

3.5.3.2.1 Usage

Sealant and fairing material applications for hydrofoils shall be classified into four types:

Type 1 - Sealing mechanically fastened joints

Type 2 - Sealing tankage

Type 3 - Sealing and smoothing hydrodynamic surfaces (fairing)

Type 4 - High-temperature applications (160⁰F to 500⁰F)

The following materials shall be used for the above applications:

Type 1 - Polysulfide sealants PR 14366 or Proseal 870 with chromates for exterior applications. For interior applications, ML-S-8802 can be used in lieu of the above sealants.

Type 2 - ML-S-8802

Type 3 - 3M EC 3517 or, for areas not subject to flexing, Hysol EA 960F.

Type 4 - For firewalls, Dapcicast 18-4. For other high-temperature applications, Dow Corning RTV 731 or G.E. RTV 174.

The use of other materials shall be submitted for NAVSEA approval per Section 4.2.3.

3.5.3.2.2 Application Procedures

Surface Preparation - Substrates shall be prepared for sealing and fairing as shown in Tables 3.5.3 and 3.5.4.

Application Environment and Cure Times and Temperatures - Sealants shall be applied to clean dry surfaces. Moisture on the application surface will cause adhesive failure. The ambient temperature for application should be between

**TABLE 3.5.3
TYPICAL PRIMER USAGE.**

Application Type	Substrate	Dapco 1-100 Primer	Navy Formula 1B53	Epoxy MIL-P-23377	Primer (Grit Blast Only)
1 2 3	Aluminum alloys			x X	X X
1 3	Low alloy steels		X x		
1 3 4	Corrosion resistant steels	X	X		X
1 3 4	Titanium alloys	x		X	X
1 3	Composites				x X

3

TABLE 3. 5. 4

SURFACE PREPARATION FOR SEALING

A. ALUMINUM ALLOYS

All Surfaces to be Sealed

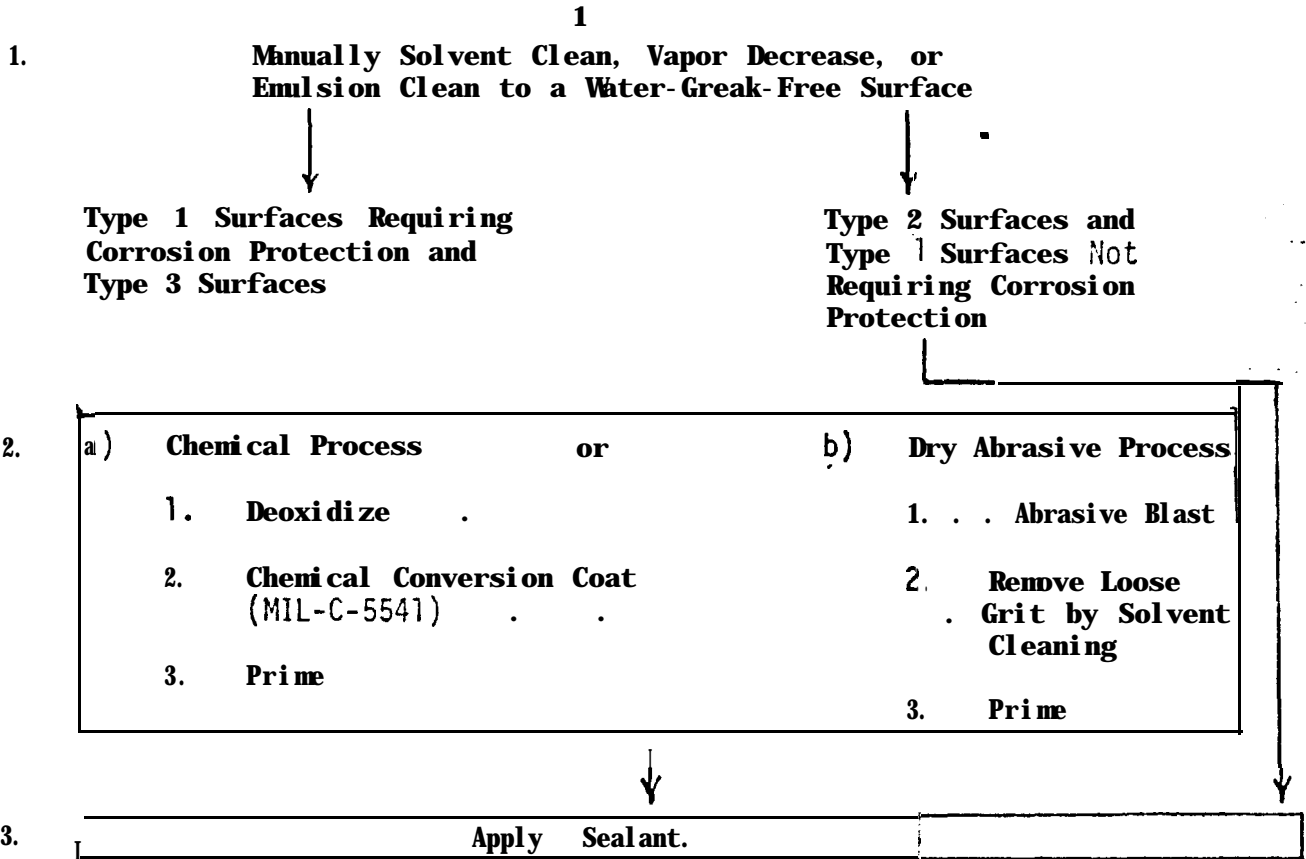

A= 3

3

TABLE 3.5.4 (Continued)

B. STEEL ALLOYS OTHER THAN CRES

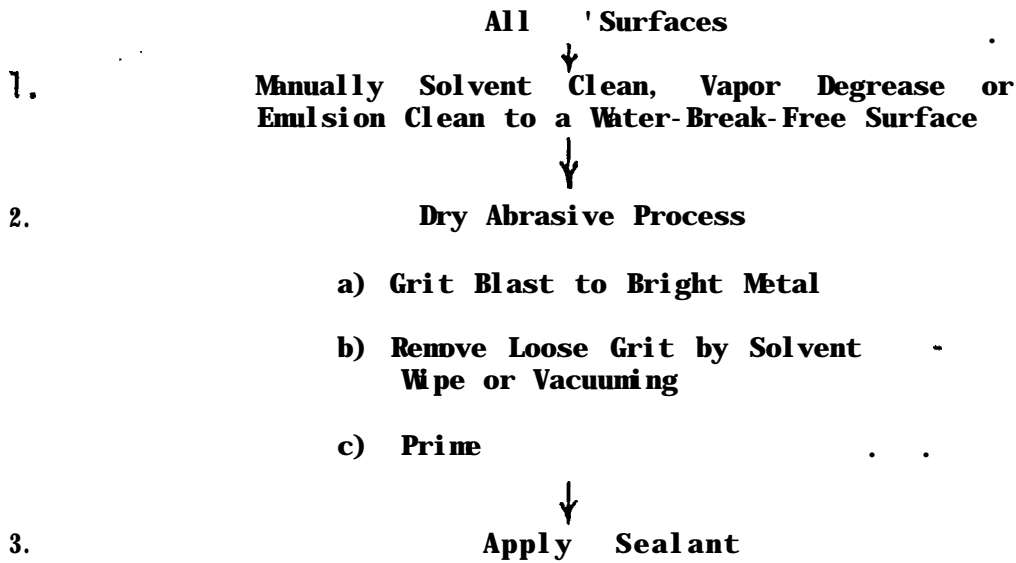

C. CRES ALLOYS

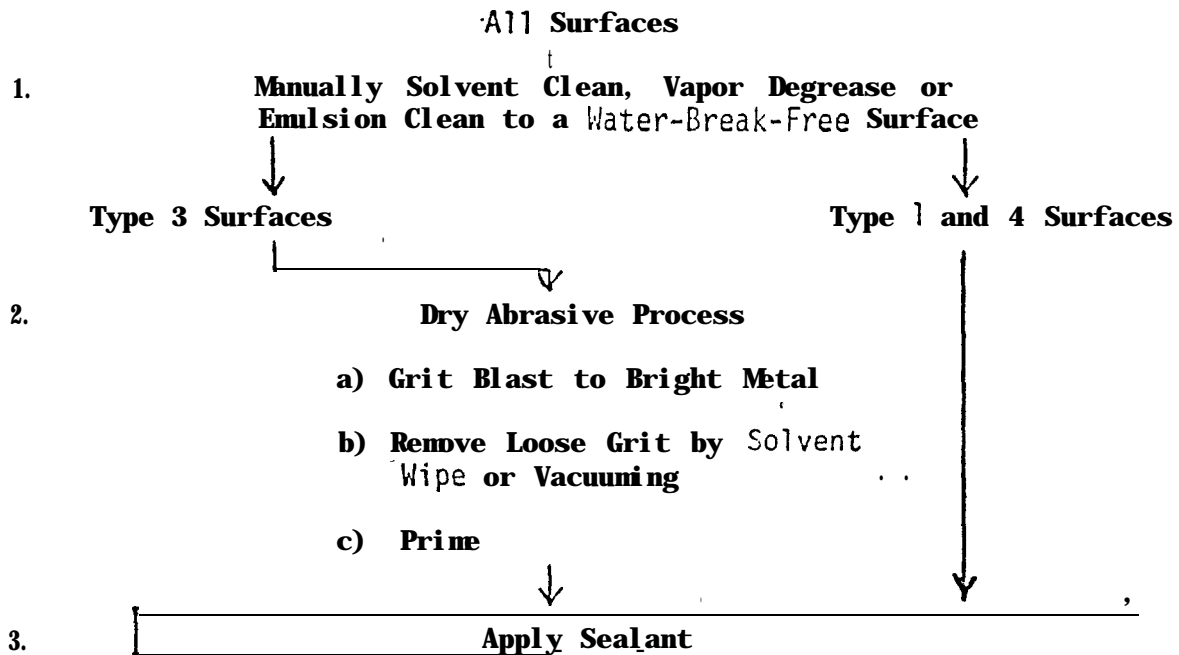
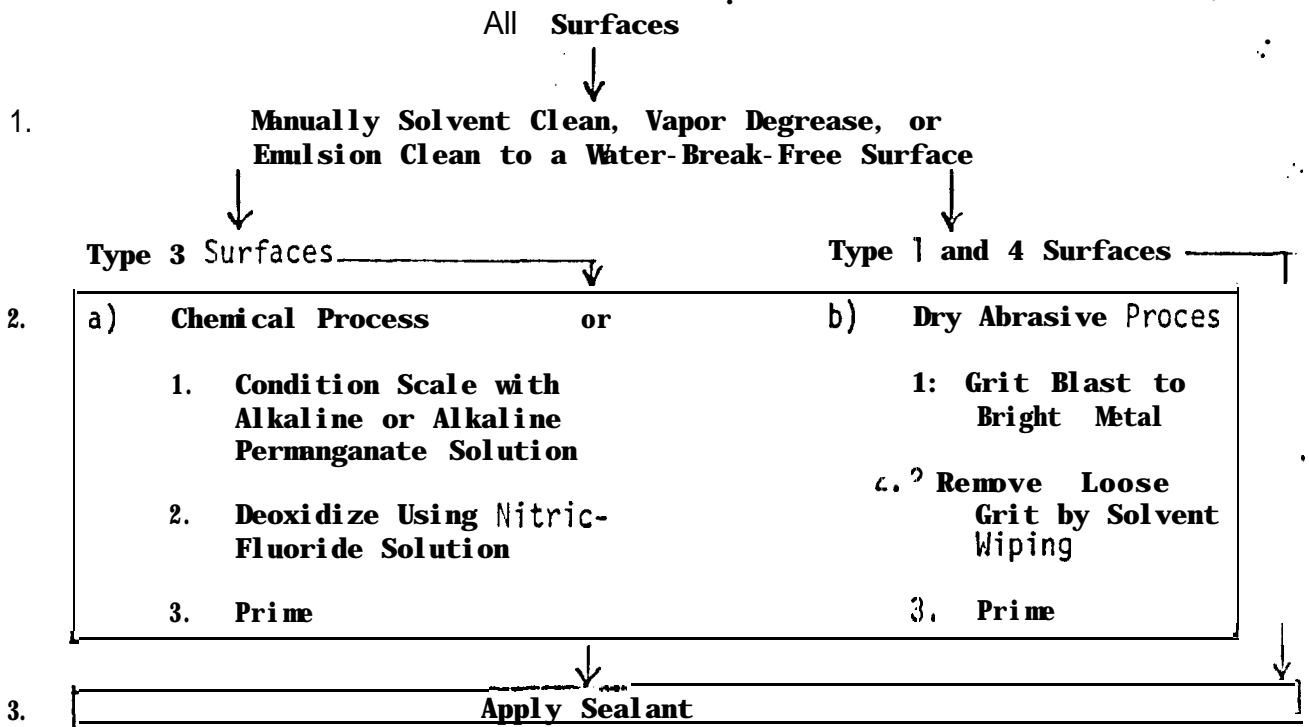
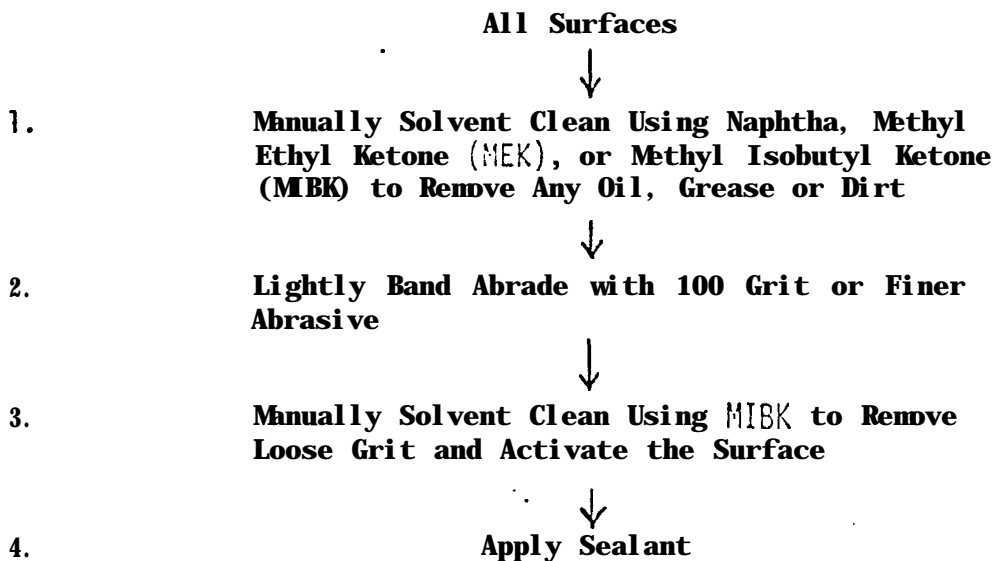

TABLE 3.5.4 (Continued)

D. TITANIUM ALLOYS



E. COMPOSITES



60⁰F and 80⁰F. Below 60⁰F, the sealant may not flow properly and moisture condensation on the application surface may occur. At temperatures above 80⁰F, the sealant application time will be lowered and the sealant may flow excessively.

Cure times and temperatures for the sealants are shown in Table 3.5.5.

Application Techniques - Sealants may be applied by spraying, brushing, rolling, spatula, sealant gun, or as a tape. The manner of application depends on the constraints of structure geometry, manufacturing sequences, and limitations of sealant materials. It also depends on the specific operation to be done such as hole filling, fastener installation, or surface fairing.

3.5.3.2.3 Service Life

Sealants shall retain the required properties for a minimum of 18 months.

3.5.3.2.4 Limitations

- a) Care must be taken to fully cure sealant materials to obtain maximum adhesion.
- b) The Type 4 silicone material will degrade the adhesion of paints.

3.5.3.3 COMPOSITES

3.5.3.3.1 Selection of the Composite Materials

The selection of the materials to be used for structural applications shall take into account all factors that affect required strength, rigidity,

TABLE 3. 5. 5
SEALANT APPLICATION AND CURE TIMES

Specifi- cation	Sealant Material	Temp. (°F)	Cure Time (hrs)	Application. Time or Pot Life (hrs)
<u>Polysulfides</u>				
None	PR1436G	75 ± 5°F		
	Class B1/2		20	1/2
	Class B2		48	2
Class C20	160		20	
	Pro Seal 870			
	Class B2		20	2
	Class C20		180	20
MIL-S- 8802	PR1422			
	Class A1/2		45	1/2
	Class B1/2		45	1/2
	Class A2		72	2
	Class B2		72	2
	PR1440			
	Class A2		72	2
	Class B2		72	2
	Pro Seal 890			
	Class A2		72	2
	Class B2		72	2
	Class C24		168	24
<u>Epoxies</u>				
None	Hysol EA960F	75 ± 5°F	24	1/2
		160 ± 5°F	1	NA
None	3M EC2517	75 ± 5°F	72	1
		150 ± 5°F	2	NA
<u>Silicones</u>				
None	Dapcast 18-4	75 ± 5°F	48	4
None	Daw Corning RTV 731	75 ± 5°F	24	NA
None	G. E. RTV 174	75 ± 5°F	24	NA

TABLE 3.5.5 (Continued)

NOTES:

D

Definition of type designations for polysulfide sealants:

Class -A A low viscosity sealant for brush or roller application.

Class B -- A heavy, thixotropic (low slump) sealant applied by extrusion gun or spatula for fillet or faying surface seals.

Class C -- A heavy type sealant with long squeeze-out life for faying surface sealing.

Class D -- An extra heavy paste type sealant for hole filling.

The dash number following Classes "A," "B," or "D" indicates the application time in hours. The dash number following the Class "C" indicates maximum squeeze-out life.

2

Cure may be accelerated by curing at 120°F maximum to a Rex Durometer reading of 30 when tested per ASTM Method D2240.

3

Cure time based on a thickness of 1/8 inch or less. Thicker applications will take longer to cure.

and structural reliability. Such factors shall include, but are not limited to, manufacturing processes; static, repeated, transient, vibratory, and shock loads; and specific effects of operating environment associated with reduced and elevated temperatures, repeated exposure to climatic, erosive, and scuffing conditions, the use of protective finishes, the effects of stress concentrations, and the effects of fatigue loads on composite endurance limit and ultimate strength. The actual values of properties used for structural design shall include such effects. Appropriate repair procedures shall be established for accepted applications of fibrous-composite construction in structures. Such procedures shall be documented for subsequent incorporation in pertinent structural repair manuals.

3.5.3.3.2 Procurement Specifications

- a) GRP shall be procured to MIL-P-17549.
- b) Advanced composite procurement specifications shall be approved by NAVSEA.

3.5.3.3.3 Properties for Structural Design

In general, reliable materials mechanical and physical properties suitable for use in structural design of fibrous composites shall be of the type that would be (obtained from Military Handbook 5 for the design of conventional-counterpart-metallic structures consistent with the required operating environments. Such properties shall be developed in accordance with procedures described in Chapter 9 of "MIL-HDBK-5 Guidelines for the Presentation of Data." However,

properties that are unique to fibrous composites, due to their special characteristics associated with directionality of fibers and construction variables, shall be included. For purposes of developing mechanical properties of the fibrous composites for use in structural design, sufficient number of specimens shall be tested to arrive at minimum mechanical property values above which at least 90 percent of the population of values is expected to fall with a confidence of 95 percent. For purposes of expeditiously completing a specific structural design, these values may be computed initially based on tests of a reduced number of specimens. Where composite laminate properties are established from single ply properties through analytical techniques, the minimum mechanical properties for the composite laminates shall be substantiated by the performance of a sufficient number of appropriate tests of the composite laminates to permit computation of minimum values by statistical analyses. All test data required to achieve the foregoing 90 percent probability/95 percent confidence level values shall be documented.

3.5.3.3.4 Limitations

Graphite composites can cause serious galvanic corrosion of more anodic materials such as aluminum and such material combinations shall require adequate insulation.

3.5.3.4 HYDRAULIC FLUIDS

Hydraulic systems shall use the MIL-H-83282 hydraulic fluid. A straw color shall be required for the fluid to distinguish it from the MIL-H-5606 fluid. Any use of "Skydrol" type materials requires special justification (see Section 3.5.3.1.4).

3.5.3.5 LUBRICANTS

Lubricants shall be consistent with Section 262 of NAVSHIPS 0902-001-5000.

3.5.3.6 TRANSPARENCIES

Transparent materials shall be as specified in Section 625 of NAVSHIPS 0902-001-5000.

3.5.3.7 THERMAL AND ACOUSTIC INSULATION

Thermal and acoustic insulation materials shall be as specified in Sections 508 and 635 of NAVSHIPS 0902-001-5000. Note: Recent fire insulation tests on aluminum panels have indicated that adequate insulation may be obtained with fiberglass-faced 4 lb/cu ft density refractory fiber board. This and comparable materials should be considered as potential insulation materials pending completion of these tests sponsored by NAVSEC 6101.

3.5.4 FASTENER MATERIALS

The following fastener materials shall be used for hydrofoil structure:

3.5.4.1 STRUTS AND FOILS

For low alloy steel components - 300 series stainless steel or A286

For corrosion resistant steel components - A286, MP35N or titanium

For titanium components - titanium or MP35N

For GRP components - A286, titanium or MP35N

3.5.4.2 HULL

Rivets - 6061 aluminum

Mechanical Fasteners

Internal - 300 series stainless steel

External - A286*

***These fasteners shall be isolated from the aluminum structure.**

3.5.4.3 LIMITATIONS

- a) **300 series stainless steel fasteners are subject to crevice attack when used with stainless steel, composite, or titanium components, and shall not be used for these applications.**
- b) **5000 series aluminum rivets are subject to exfoliation corrosion and shall not be used for exterior applications.**
- c) **A286 fasteners with A286 nuts should be sealed to avoid crevice corrosion under constant immersion conditions.**

3.5.5 COMPONENT APPLICATIONS

The following applications are critical and materials and associated processes selected for their fabrication shall be justified in the rationale required in Section 3.5.1.1. Applications in addition to those itemized below that meet the critical definition (Section 6.1) shall also be included in the rationale. Note: The present state-of-the-art on material applications is summarized in the Substantiation Document, Volume IA.

- 3.5.5.1 STRUTS AND FOILS**
 - 3.5.5.1.1 Linkages**
 - 3.5.5.1.2 Bearings**
 - 3.5.5.1.3 Flaps**
 - 3.5.5.1.4 Coating, Sealant, and Fairing Materials (as applicable)**
- 3.5.5.2 HULL AND SUPERSTRUCTURE**
 - 3.5.5.2.1 Coating, Sealant, and Fairing Materials**
- 3.5.5.3 PROPULSION COMPONENTS (As Applicable)**
 - 3.5.5.3.1 Propellers**
 - 3.5.5.3.2 Waterjet Pumps**
 - 3.5.5.3.3 Water Ducts and Inlets**
 - 3.5.5.3.4 Bearings**
- 3.5.5.4 PIPING SYSTEMS**
 - 3.5.5.4.1 Hydraulic**
 - 3.5.5.4.2 Seawater Systems**
 - 3.5.5.4.3 Fresh Water**

3.5.6 MATERIAL ACCOUNTABILITY

The traceability of materials used for critical component applications (Section 6.1) shall be maintained through records that include the following:

- a) Vendor part number**
- b) Material identification**
- c) Heat lots and chemistries (where applicable)**
- d) Heat treat condition (where applicable)**
- e) Processing sequence**
- f) Inspection sequence**

4. QUALITY ASSURANCE

4.1 SHIP TESTS

Ship tests shall be conducted in accordance with the General Specifications for Ships of the United States Navy, Sections 092 "Shipboard Tests," 094 "Ship Trials," 095 "Test Requirements," and 097 "Inclining Experiment and Trim Dive." Specialized hydrofoil ship tests shall be conducted in accordance with the Hydrofoil Design Criteria and Specifications, Section 14 "Special Requirements for Test and Evaluation of Hydrofoil Ships."

4.2 MATERIALS TESTS

4.2.1 MATERIAL INSPECTION PLAN

An inspection plan shall be prepared and submitted for approval as a section of the material selection rationale (Section 3.5.1.1 of this document). As a minimum, this plan shall include:

- a) Sampling procedure and required tests for incoming material.
- b) Procedure and data that demonstrate the reliability of the test methods to detect unacceptable conditions in the materials.

4.2.2 MATERIAL PROPERTY DATA GENERATION

Mechanical property data that are not available in Section 3.5.2.2 may be generated using the test procedures found in Table 4.2.1 and the properties developed in accordance with the MIL-HDBK-5 Chapter 9 Guidelines for the Presentation of Data. If additional properties are required for design, a data generation plan shall be prepared and submitted to NAVSEA for approval.

4.2.3 SEALANT/FAIRING MATERIAL QUALIFICATION

The following test procedures and evaluations shall be used to qualify sealants. Table 4.2.2 contains the evaluation criteria for sealants applicable to each of the four applications defined in Section 3.5.3.2.1 when tested according to the procedures described below.

4.2.3.1 ADHESIVE STRENGTH

The adhesive strength shall be determined by lap shear tests per Section 4.8.13 and peel tests per Section 4.8.12 of MIL-S-8802.

4.2.3.2 EROSION RESISTANCE

Salt water flow erosion resistance shall be determined by testing in an apparatus described in Appendix II or the NSRDC High-Speed Water Tunnel. Cavitation erosion resistance shall be measured by testing per ASTM method G32-72.

4.2.3.3 IMPACT RESISTANCE

A Gardner Impact Tester or dropping a standard steel ball shall be used to evaluate the effect of impact on the bond between substrate and sealant. A test method using the Gardner Tester is described in Method 6226 of Federal Test Method Standard No. 141, and a dropping ball test is described in Section 4.6.8 of MIL-C-24176.

4.2.3.4 FLEXIBILITY

Flexibility of sealants shall be compared by testing specimens in a flexibility jig per Section 4.8.11 of MIL-S-8802.

4.2.3.5 FLUID RESISTANCE

Specimens consisting of sealant applied to a substrate shall be immersed in the following test fluids: TT-S-735 Type VII standard test fluid, ASTM D1141 standard seawater, and ML-H-5606 hydraulic fluid, at 70⁰F for 30 days per Federal Test Method Standard No. 141, Method 6011. After the 30-day immersion, the specimens should exhibit no softening, swelling, or cracking.

4.2.3.6 WEATHERING RESISTANCE

Resistance of sealants to exposure to rain and sunshine shall be evaluated by testing in the Atlas Weatherometer at 140⁰F with alternate water-spray and sunshine per ASTM method G23.

4.2.3.7 SHRINKAGE

The shrinkage of sealants shall be tested per Appendix I for Types I and II and per Section 4.6.12 of ML-C-24176 for Type III.

4.2.3.8 EASE OF APPLICATION

Sealants shall be evaluated by using hand mixing methods and examining mixed sealants to determine if uniformity is obtained. Samples of sealant stored for 12 months at 70⁰F shall be tested to the criteria in Table 4.2.2 to determine if the material has a shelf life of 12 months.

4.2.3.9 REPAIRABILITY

Samples of representative substrates and sealants should be prepared with repairs made under simulated service conditions and tested against Table 4.2.2 as applicable.

TABLE 4.2.1

Approved Test Procedures For
Mechanical Property Testing

Tensile: Use ASTM E8 plus the following:

Test Temperature - 65⁰ to 75⁰F

Strain Rate - 0.005 in/in/min. to yield.

Yield Strength - The 0.2 percent offset method shall be used to calculate yield strength.

Compression: Use ASTM E9 plus the following:

Test Temperature - 65⁰ to 75⁰F.

Strain Rate - 0.005 in/in/min.

Bearing Use ASTM E238 plus the following:

Test Temperature - 65⁰ to 75⁰F

Strain Rate - The recommended 0.05 in per minute shall be used.

Mdulus Use ASTM E111 for Youngs Mdulus and ASTM E143 for Shear Mdulus plus the following:

Test Temperature - 65⁰ to 75⁰F

Strain Rate - Youngs Mdulus 0.005 in/in/min.

Charpy Use ASTM E23 plus the following:

Test Temperature - 65⁰ to 75⁰F

Fracture Use ASTM E399 plus the following:

Test Temperature - 65⁰ to 75⁰F

Note: The net section stress shall not exceed 80 percent of the yield strength at P_Q.

TABLE 4.2.1 (Cont.)

Dynamic Tear Testing

Use ML-STD-1601

Fatigue Testing

Use ASTM E466 plus the following:

Temperature - 65⁰ to 75⁰F.

Specimen configuration - Figure 3 of E466-72T.

Environments - air and 3 1/2 percent NaCl in distilled water.

Surface Finish - 80 to 125 RHR in test area.

Stress Ratio - 0.06.

Data Presentation - Graphical Plot of max stress vs. 10⁵ to 10⁷ cycles:

Note: Metals subject to work hardening shall be stress relieved after final machining.

Stress Corrosion Cracking



Use NRL Report 7865 plus the following:

o Test Temperature - 65⁰ to 75⁰F

o Environment - 3 1/2 percent NaCl in distilled water..

Note: Net section tension stress shall not exceed 90 percent of Fty.

TABLE 4.2.2 - EVALUATION CRITERIA FOR AHPS SEALANTS

Type	Adhesive Strength	Erosion Resistance	Impact Resistance	Flexibility	Fluid Resistance	Weathering Resistance	Shrinkage
1.	Minimum 20 lb per inch peel	NA	Minimum 60 in.-lb without adhesive failure at 25°F	No adhesive failure at -65°F	No degradation after 30 days in test fluid at 90°F	NA 	Maximum of 1%
2	Minimum 20 lb per inch peel	NA	NA	No adhesive failure at 25°F	No degradation after 30 days in test fluid at 90°F	NA 	Maximum of 1%
3	Minimum 1400 psi lap shear	Minimum 100 hours erosion and 2 hours cavitation erosion. No adhesive or cohesive failure.	Minimum 60 in.-lb without adhesive failure at 25°F	No adhesive failure at -65°F	No degradation after 30 days in test fluid at 90°F	No degradation after 500 hours	Maximum of 0.25%
4	Minimum 150 psi lap shear	NA	NA	No adhesive failure at 70°F after sealant has been exposed to 400°F for 7 days	NA	No degradation after 500 hours	NA after



Test fluids are: (1) TT-S-735 Type III standard hydrocarbon test fluid, (2) ASTM 01141 standard seawater, and (3) MIL-H-5606 hydraulic oil,

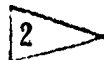

Not considered applicable to Type 1 and 2 materials since they will generally not be exposed to weathering conditions.

5. PREPARATION FOR DELIVERY

This section describes the drawings and reports required for hydrofoil designs. The absence of any drawing or report required by other regulations or specifications does not eliminate the requirement for that drawing or report.

5.1 DRAWINGS

All drawings shall be prepared in accordance with U.S. Government standards (see General Specifications Section 085). Where possible, dimensions shall be given in both International Standard (SI) and U.S. Customary units. If it is not possible to give dimensions in both systems, the SI system shall be used. Each drawing shall state clearly the system in which the calculations were performed.

All drawings required by specification or U.S. Navy practice shall be supplied, as appropriate (see General Specifications Section 085).

A set of foil/strut system drawings shall be included in the Booklet of General Drawings. These shall define the overall dimensions of the struts, foils and pods in three planes. They shall clearly describe, either verbally or diagrammatically, the strut and foil sections. The location of the struts/foils with relation to the hull shall be clearly shown. In particular, the retraction scheme, if applicable, shall be shown.

5.2 REPORTING

The reports described below are required. However, all other reporting requirements defined by contract or specification remain in effect.

5.2.1 WEIGHT REPORTING

Weights shall be reported by Ship Work Breakdown Structure (SWBS). They shall be reported in accordance with the General Specifications for Ships of the United States Navy, Section 096 "Weights for Surface Ships."

The weight and center of gravity values for the Lift Systems (SWBS 567) shall be specifically listed in all weight reports, including those to the one-digit level.

A special "Hydrofoil Weight History Report" shall be prepared. It shall show the time history of each weight group and the total ship, both light ship weight and full load weight. It shall show weight and center of gravity location in all three planes. This shall be to the one-digit level except that SWBS 567 shall be shown. It shall be updated with each weight report. It shall be in both tabular and graphical form

5.2.2 SHIPS CHARACTERISTICS DATA

All hydrofoil ship program activities shall use the General Characteristics Data Sheets and Detail Characteristics Data Sheets for presenting basic and detail ship characteristics data in an easily referred to standard format.

5.2.2.1 GENERAL CHARACTERISTICS DATA SHEETS

A separate set of data sheets shall be maintained and updated periodically for each of the following ship development phases: preliminary design, contract design and detail design.

The ship designation, designer and/or builder shall be clearly indicated in the title block of the data sheet. The specific data shall be presented in the following general categories: Weight Summary, Dimensional Characteristics, and Performance Characteristics.

Weight Summary

The weight summary shall be in tabular form similar to Table 5.2.1 and shall include all weight items shown for the ship operating at the calm water foilborne design waterline.

Dimensional Characteristics

Physical dimensions, locations and reference lines shall be presented on an inboard profile and front view drawing of the ship and shall include the following:

Baseline and forward aft perpendiculars shall be shown as

dimensional references

Length Overall Foilborne (LOF)

Length Overall Hullborne (LOH)

Length Overall Hull Molded (LOA)

Maximum length during foil retraction

Maximum width during foil retraction

Length between perpendiculars

Foil longitudinal locations

Molded beam

Extreme beam foils down

Extreme beam foils up

Hull depth

Mast height

Foil submergence

Hull design waterline

Design waterline foils down

Calm water foilborne design waterline

Rough water foilborne design waterline

Maximum draft hullborne, foils down

Extended range fuel tankage location

Normal fuel tankage location

Location of watertight bulkheads

Outline of deckhouse, mast, and deck equipment

Frame locations and spacing

The fuel capacity of each tank, including normal and extended range fuel, shall be shown in tabular form in units of weight. Locations of longitudinal and vertical centers of gravity, relative to the forward perpendicular and baseline respectively, may be presented in tabular form and shall include locations for the following conditions: minimum operating condition (hullborne and foilborne), delivered full load displacement (hullborne and foilborne).

Performance Characteristics

Performance characteristics presented on the data sheets shall include the following, for the design full load displacement condition:

Calm water foilborne design speed

Calm water foilborne cruise speed

Dash speed

Normal foilborne range
Extended foilborne range
Foilborne turning diameter
Hullborne design speed
Hullborne turning diameter
Rough water foilborne cruise speed
Rough water foilborne design speed
Wind loading

5. 2. 2. 2 DETAIL CHARACTERISTICS DATA SHEETS

These data sheets shall be maintained and periodically updated throughout the detail design and construction phases of each specific ship development.

Detail characteristics shall be presented in tabular form and shall be listed by SWBS groupings for the following categories of data: Category I, Weights; Category II, Dimensions; Category III, Material; Category IV, Design Characteristics; and Category V, Other. The level of detail presented shall include SWBS Group, Sub-Group, and Element. Table 5.2.2 is a typical Detail Characteristic Data Sheet.

REVISION _____	PREPARED BY <u>ALV/AV</u>
DATE <u>9-4-73</u>	CHECKED <u>FLW</u>
SHEET <u>G1</u>	APPROVED _____

ELEMENT _____
ELEMENT TITLE _____
ELEMENT PAGE <u>1</u> OF <u>100</u>

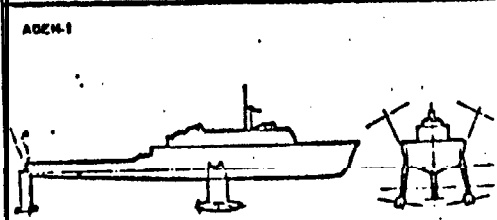
	WEIGHT OF HULL STRUCTURE (100) (TBM/REV)	WEIGHT OF (110)	WEIGHT OF (120)	WEIGHT OF (130)	WEIGHT OF (140)	WEIGHT OF (150)	WEIGHT OF (160)	WEIGHT OF (170)	WEIGHT OF (180)	WEIGHT OF (190)
ADEN-1 	91.30 (204,517)	33.81 (75,742)	10.25 (22,760)	10.98 (24,614)	12.32 (27,608)	5.21 (11,678)	6.18 (13,846)	.57 (1,275)	9.03 (20,233)	2.92 (6,541)
	0.6914	0.6914	0.6914	0.6914	0.6914	0.6914	0.6914	0.6914	0.6914	0.6914

WOS 100 DATA CATEGORY 1

TABLE 5.2.2 - TYPICAL DETAIL CHARACTERISTICS DATA SHEET

APPENDIX I

6.2 SHRINKAGE TEST (TYPE 1 AND 2 SEALANTS - CLASS B ONLY)

6.2.1 TEST CONDITIONS

6.2.1.1 STANDARD TEST CONDITIONS

Standard laboratory testing conditions shall be $77 \pm 2^{\circ}\text{F}$ and $50 \pm 5\%$ relative humidity. Except as otherwise specified hereinafter, all test specimens shall be prepared, cured, and tested under these conditions.

6.2.1.2 CURE CONDITIONS

All references to a Standard Cure in this specification shall mean a cure in a period of time as specified in Table 6.2.1 under standard laboratory testing conditions.

TABLE 6.2.1

<u>Class-Dash No.</u>	<u>Standard Cure</u>
B-1/2	7 days
B-2	7 days
B-4	7 days
B-8	14 days

All tests on the cured specimens shall commence not later than 2 days after completion of the specified cure period.

6.2.2 TEST PROCEDURE

Three strips ($\frac{1}{2}$ x $\frac{1}{2}$ x 6 inches) of sealant shall be prepared in the mold shown in Figure 6.2.1. The mold shall be coated with a suitable parting agent to aid in removal of the cast strips. After standard cure time as listed in Table 6.2.1, the strips shall be removed from the mold, the ends squared, if necessary, and the length measured. The strips shall be stored at standard conditions per Section 30.1.1 for 60 days and the length again measured. The shrinkage shall be reported as percentage of the original length.

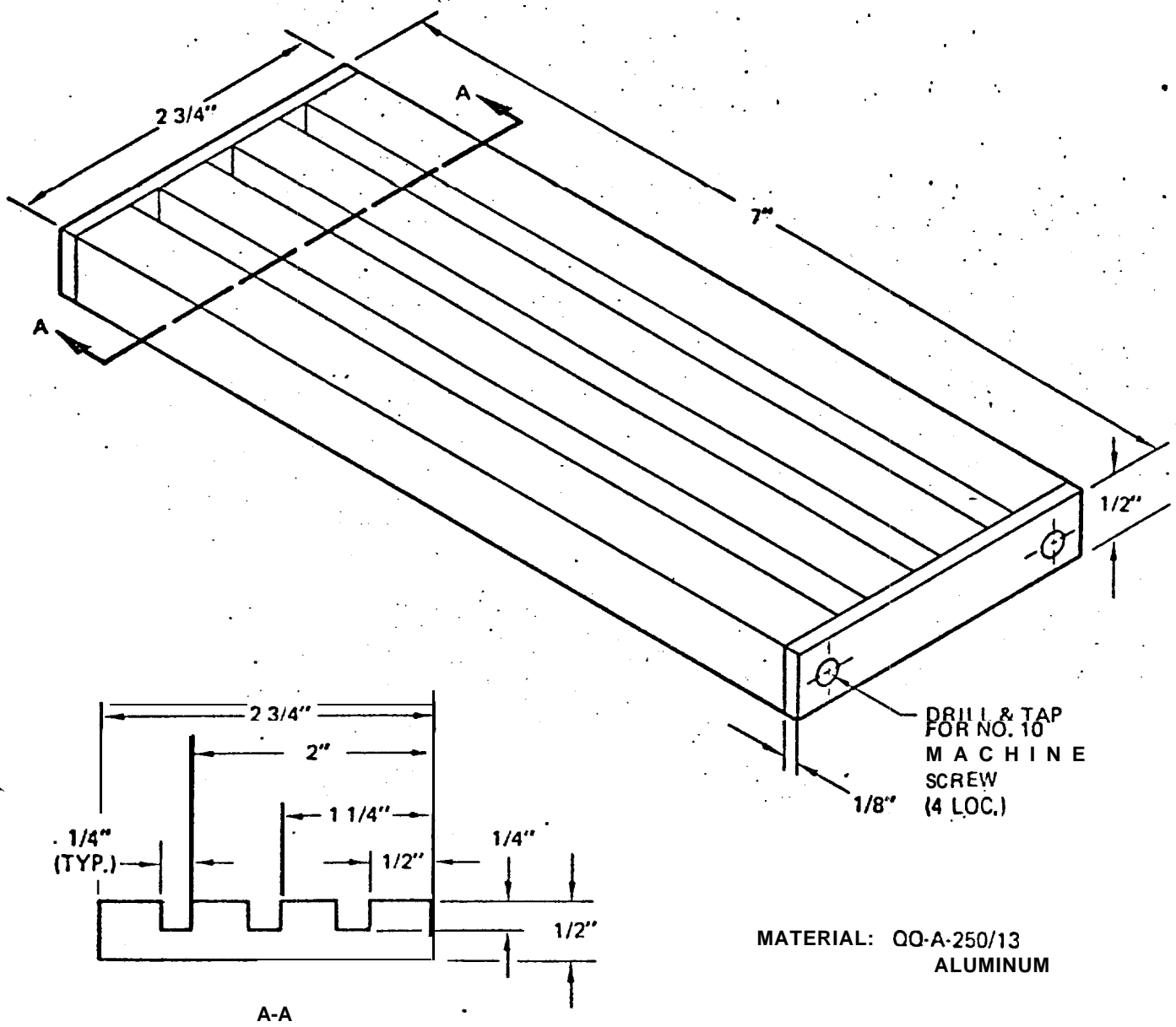

Figure 6.2.1 - Shrinkage Test Jig

APPENDIX II

6.3 SALT WATER IMPINGEMENT EROSION TEST (TYPE 3 SEALANTS)

6.3.1 TEST CONDITIONS

6.3.1.1 STANDARD TEST CONDITIONS

- a) Water temperature - $100 \pm 5^{\circ}\text{F}$
- b) Water velocity - 52 knots
- c) Impingement angle - 45°
- d) Specimen size - 3 x 8 inches
- e) Specimen thickness - 0.050 inch maximum

6.3.1.2 SEALANT CURE CONDITIONS

Sealants shall be cured per manufacturer's recommendations for maximum physical properties.

6.3.2 TEST PROCEDURE

Sealants are applied to test panels to a thickness of 0.125 ± 0.030 inch. After curing per Section 6.3.1.2, the sealant material is cut to base metal in a cross pattern from corner to corner. Then the panel is impacted in the center of the cross using 60 in.-lb and a Gardner Impact Tester. The specimens are then placed in the erosion tester described in Section 6.3.3.

6.3.3 TEST EQUIPMENT

The testing apparatus is shown in Figures 6.3.1 and 6.3.2. The water velocity of the test apparatus is adjusted by controlling the flow through the valve to the cross tee (Figure 6.3.2) to maintain the pressure necessary to obtain 52 knots at the nozzle as shown in the calibration curve in Figure 6.3.3. The water temperature is controlled by a cold water cooling coil in the sump.

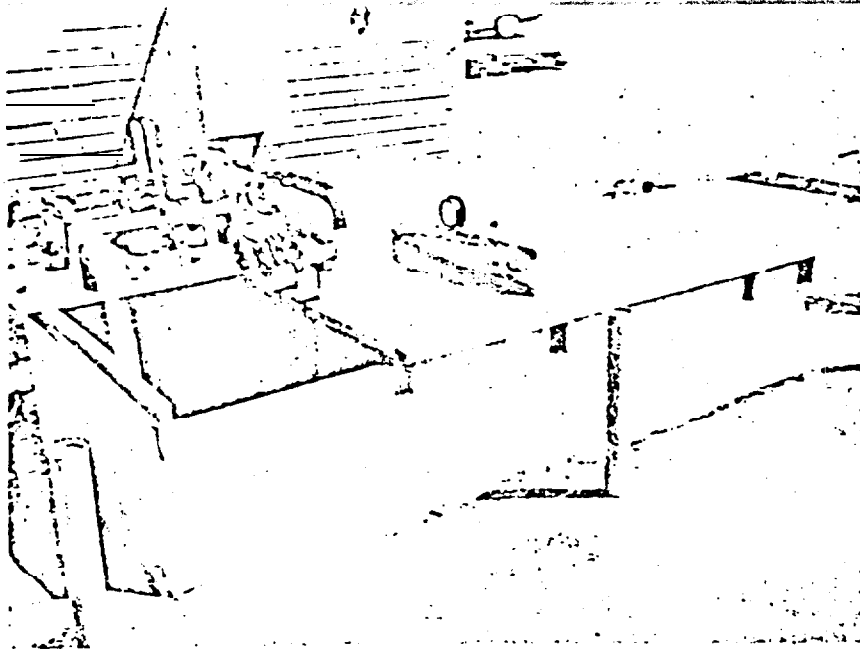

OVERALL VIEW

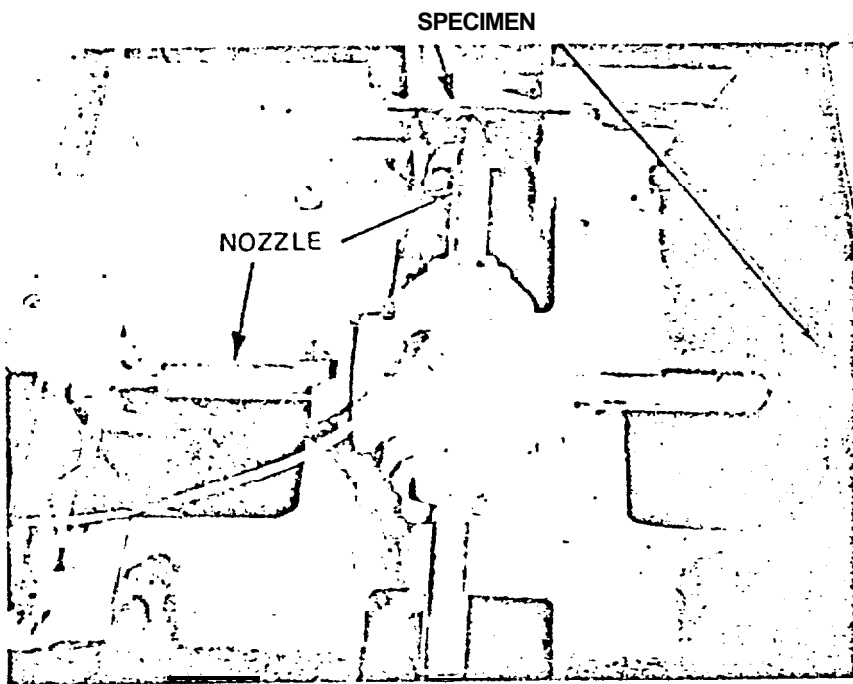

VIEW OF NOZZLES AND SPECIMENS

Figure 6.3.1 - Salt Water Erosion Test Facility

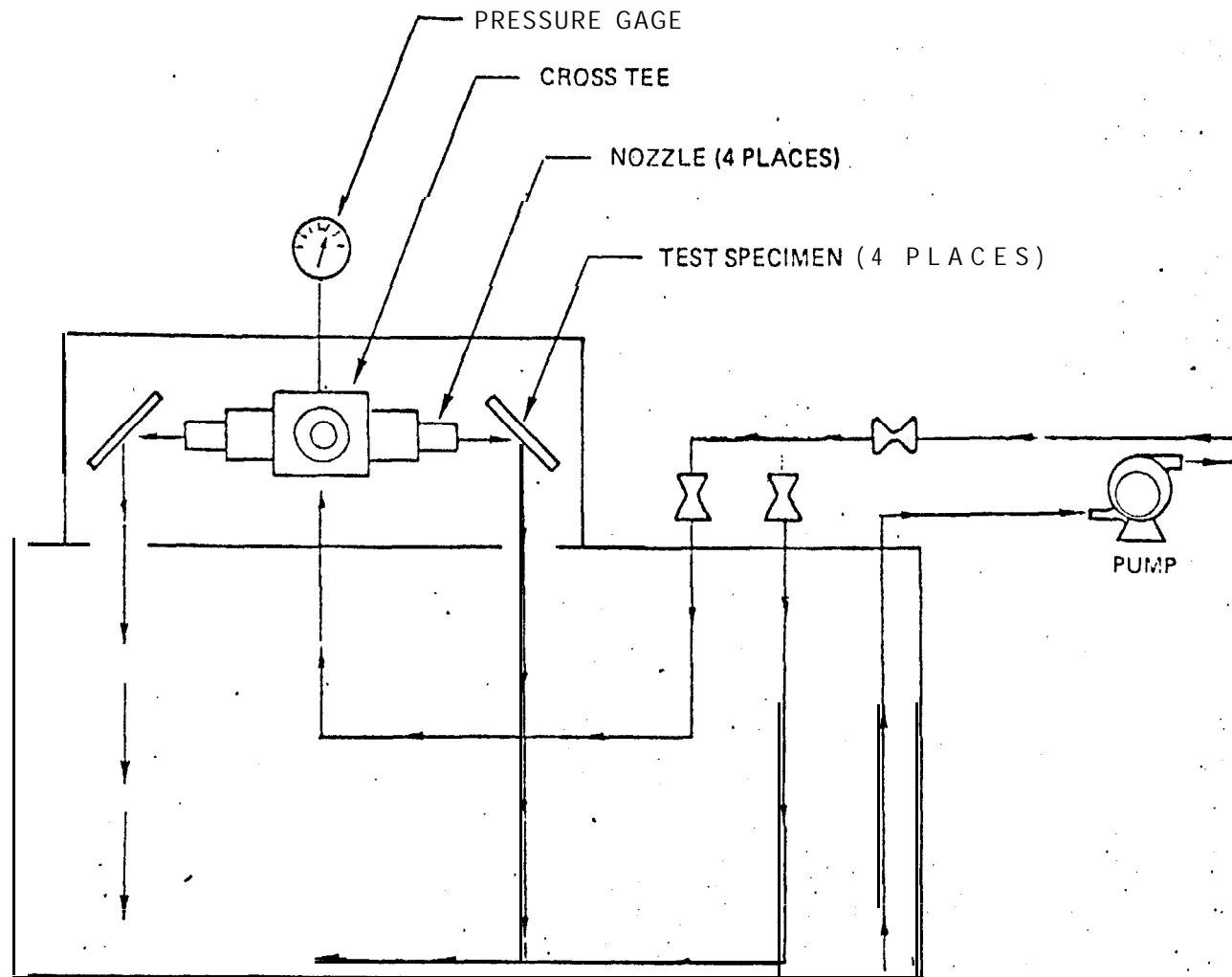

Figure 6.3.2 - Schematic of Salt Water Erosion Test Facility

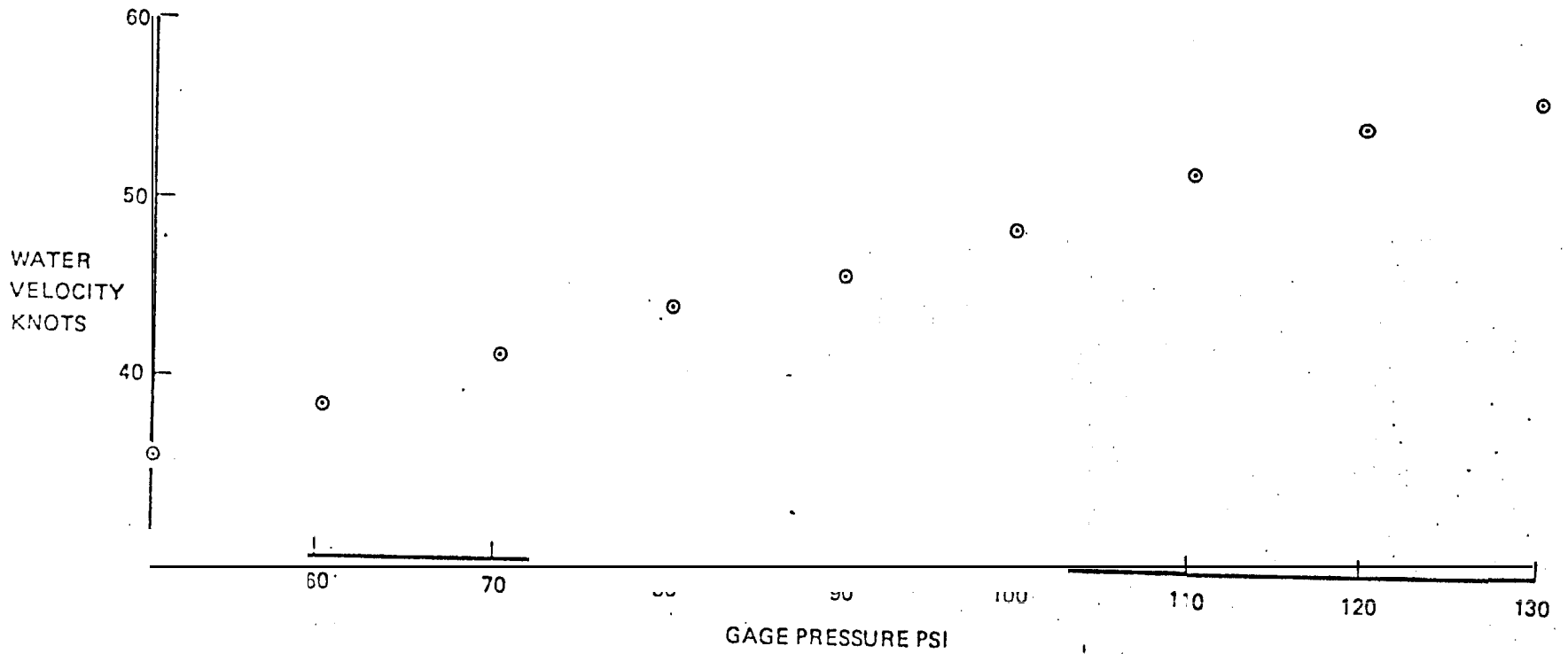

Figure 6.3.3- Gage Pressure versus Water Velocity at Nozzle --
Salt Water Erosion Test Facility

**DESIGN CRITERIA AND SPECIFICATIONS
FOR U. S. NAVY HYDROFOIL SHIPS**

VOLUME IA

GENERAL INFORMATION - SUBSTANTIATION

(Draft: 18 December 1980)

10-V16208

HYDROFOIL DESIGN CRITERIA AND SPECIFICATIONS

GENERAL INFORMATION MANUAL

OUTLINE

1. Scope

1.1 Purpose of the Design Criteria

1.2 Criteria Applicability and Use

2. Applicable Documents

2.1 Design Criteria and Specifications for U.S. Navy Hydrofoil Ships

2.2 Other Applicable Documents

3. Requirements

3.1 Overview and Management

3.2 Weight and Center of Gravity Margins

3.2.1 Preliminary Design Weight Margins

3.2.1.1 Margins in Light Ship Weight

3.2.1.2 Margin in Full Load Weight

3.2.2 Contract Design Weight Margin

3.2.2.1 Margins in Light Ship Weight

3.2.2.2 Margin in Full Load Weight

3.2.3 Detail Design Weight Margins

3.2.3.1 Margins in Light Ship Weight

3.2.3.2 Margin in Full Load Weight

3.2.4 Center of Gravity Margins

3.3 Environment

3.3.1 Temperature, Humidity and Barometric Pressure

3.3.2 Sea State

3.3.3 Wind Speed/Direction

3.4 Static Stability

3.5 Materials and Manufacturing Technology

3.5.1 General

3.5.1.1 Material Selection

3.5.1.2 Standardization

3.5.2 Metallic Materials

3.5.2.1 Procurement Specifications

3.5.2.2 Mechanical and Physical Properties

3.5.2.3 Processing

3.5.2.4 Limitations

3.5.2.4.1 Low Alloy Steels

3.5.2.4.2 Corrosion Resistant Steels

3.5.2.4.3 Aluminum Alloys

3.5.2.4.4 Titanium Alloys

3.5.2.4.5 Nickel Alloys

3.5.2.4.6 Copper Alloys

3.5.3 Non-Metallic Materials

3.5.3.1 Coatings

3.5.3.1.1 Usage

3.5.3.1.2 Life Expectancy

3.5.3.1.3 Coating Application

3.5.3.1.4 Limitations

3.5.3.2 Sealants and Fairing Materials

3.5.3.2.1 Usage

3.5.3.2.2 Application Procedures

3.5.3.2.3 Service Life

3.5.3.2.4 Limitations

3.5.3.3 Composites

3.5.3.3.1 Selection of Composite Materials

3.5.3.3.2 Procurement Specifications

3.5.3.3.3 Properties for Structural Design

3.5.3.3.4 Limitations

3.5.3.4 Hydraulic Fluids

3.5.3.5 Lubricants

3.5.3.6 Transparencies

3.5.3.7 Thermal and Acoustic Insulation

3.5.4 Fastener Materials

3.5.4.1 Struts and Foils

3.5.4.2 Hull

3.5.4.3 Limitations

3.5.5 Component Applications

3.5.5.1 Struts and Foils

3.5.5.1.1 Linkages

3.5.5.1.2 Bearings

3.5.5.1.3 Flaps

3.5.5.1.4 Coating, Sealant, and Fairing Materials

3.5.5.2 Hull and Superstructure

3.5.5.2.1 Coating, Sealant, and Fairing Materials

3.5.5.3 Propulsion Components

3.5.5.3.1 Propellers

3.5.5.3.2 Waterjet Pumps

3.5.5.3.3 Water Ducts and Inlets

3.5.5.3.4 Bearings

3.5.5.4 Piping Systems

3.5.5.4.1 Hydraulic

3.5.5.4.2 Seawater Systems

3.5.5.4.3 Fresh Water

3.5.6 Material Accountability

3.6 Shock and Vibration

4. Quality Assurance

4.1 Ship Tests

4.2 Materials Tests

4.2.1 Material Inspection Plan

4.2.2 Material Property Data Generation

4.2.3 Sealant/Fairing Material Qualification

4.2.3.1 Adhesive Strength

4.2.3.2 Erosion Resistance

4.2.3.3 Impact Resistance

4.2.3.4 Flexibility

4.2.3.5 Fluid Resistance

4.2.3.6 Weathering Resistance

4.2.3.7 Shrinkage

4.2.3.8 Ease of Application

4.2.3.9 Repairability

5. Preparation For Delivery

5.1 Drawings

5.2 Reporting

5.2.1 Weight Reporting

5.2.2 Ships Characteristic Data

5.2.2.1 General Characteristics Data Sheets

5.2.2.2 Detail Characteristics Data Sheets

6. Notes

6.1 Glossary and Abbreviations

6.2 Appendix I - Shrinkage Test (Types 1 and 2 Sealants - Class B Only)

6.2.1 Test Conditions

6.2.1.1 Standard Test Conditions

6.2.1.2 Cure Conditions

6.2.2 Test Procedure

6.3 Appendix II - Salt Water Impingement Erosion Test (Type 3 Sealants)

6.3.1 Test Conditions

6.3.1.1 Standard Test Conditions

6.3.1.2 Sealant Cure Conditions

6.3.2 Test Procedure

6.3.3 Test Equipment

T A

1. SCOPE

1.1 PURPOSE OF THE DESIGN CRITERIA

A number of experimental hydrofoil models were constructed beginning in 1947. The U.S. Navy Hydrofoil Advanced Development Program began in 1960. This resulted in the construction of several large developmental and operational hydrofoil ships (Figure 1.1.1). The Navy has funded series production of PHM class ships. The commercial Jetfoil hydrofoils are in production. Series production of FLAGSTAFF MKII hydrofoils is expected. Many lessons have been learned from these, and other, programs. These lessons have been incorporated into these general criteria. They are expected to be the technical foundation for future hydrofoil programs.

Conventional design and construction practices have been used to the greatest extent possible in these criteria. However, hydrofoils are generally relatively small, light, high-performance ships. They also have specialized lift, propulsion, and control systems. These lead to some variations in equipment, practices, and standards. These deviations from the conventional should be minimized in order to allow better integration of hydrofoils with the rest of the fleet.

These Design Criteria and Specifications are to be "living." They are expected to change as time passes. Just as lessons have been learned from previous programs, each generation of hydrofoil will result in new advances and the development of new technology. Navy needs and practices will also change.

1.2 CRITERIA APPLICABILITY AND USE

U. S. Navy hydrofoil interest has been centered on fully-submerged, sub-cavitating hydrofoils. Since this forms the basis for these criteria, their applicability can only extend to these types. However, some portions may also be usable for surface-piercing or supercavitating hydrofoils. If such use was to be made, careful review would be necessary.

Since these are general criteria, it is possible that some parts may be excluded by future hydrofoil programs. However, this would not be expected to be common.

Most general ship specifications and standards were written for displacement ships. They did not consider the size and weight constraints which are imposed on hydrofoil ships. Many of the conventional standards are invoked in these criteria. However, some of them just cannot be applied to hydrofoils. It is for this reason that the hydrofoil criteria must carry precedence over other standards and specifications, for hydrofoil ships. The conflicts with the displacement ship standards are not expected to be frequent and very few are of large magnitude. As will be discussed later, these new standards will also require more careful design.

Technical substantiation is provided for each element of the criteria. This explains the basis for the criteria and should aid in making changes. It also should help in the understanding and proper application of the criteria.

2. APPLICABLE DOCUMENTS

2.1 DESIGN CRITERIA AND SPECIFICATIONS FOR U.S. NAVY HYDROFOIL SHIPS

Of the fourteen parts which form the hydrofoil criteria, only the first five are complete. Tables of contents of parts two through five are shown in Tables 2.1.1A through 2.1.1D.

Summaries of the contents of criteria and substantiation volumes six through fourteen are shown in Table 2.1.2.

2.2 OTHER APPLICABLE DOCUMENTS

Table 2.2.1 shows all of the documents applicable to parts one through five of the hydrofoil criteria and the parts to which they apply. Those specifically applicable to part one are listed in the criteria volume.

3. REQUIREMENTS

3.1 OVERVIEW AND MANAGEMENT

The criteria in Volume I are those which are applicable to several disciplines. They are included in this volume so that conflicts can be minimized. For instance, these relate to the common, external environmental conditions in which the ship finds itself. The internal environment is covered in the other parts of the criteria.

Similarly, unified terms and definitions are found in the General Information volume. There are no terms which are used in more than one volume with differing meanings.

Certain items not covered in the other criteria are included here. These include weight and center of gravity control, specialized reporting, and materials.

No specific management plan or reporting methods are required except for weight reporting and reporting of key parameters discussed in the "Reporting" section of Volume I and those required by other volumes. The designers and constructors of hydrofoil ships are encouraged to exercise imagination and judgement in these areas. This does not preclude reporting required in the contract or reporting required by other regulations.

The Hydrofoil Analysis and Design (HANDE) program is a computer-aided design tool. It was developed by the U.S. Navy to make the latest hydrofoil state-of-the-art available to hydrofoil ship design teams. HANDE is available for

qualified government and private users. It may be used for designs through early preliminary design. A continual effort is made to incorporate the hydrofoil design criteria and specifications in the program

3.2 WEIGHT AND CENTER OF GRAVITY MARGINS

Hydrofoil ships are "weight critical." Any weight overload and many shifts in center of gravity will have a harmful effect on foilborne performance. This is more serious than would be experienced on a displacement ship. The following paragraphs describe these effects:

Weight Growth - This leads directly to a reduction of payload or fuel which, in turn, leads to a range reduction. It may also cause foil overload, which results in increased resistance and reduced foil life. The increased resistance may result in a speed loss, a required increase in power, increased fuel consumption, and further decreased range. It may also have a negative impact on ship static stability and dynamic control.

Rise in Center of Gravity - This has an obvious impact on static stability. It may also hurt dynamic control.

Longitudinal Change of Center of Gravity - This can lead to overload of one foil system with many of the same problems as discussed under weight growth. These include reduced foil life, increased resistance, power, and fuel consumption, reduced range, speed loss, and control problems.

Some of these problems were present during the design of AGEH-1. Almost all of the effects listed above have been present in the operation of PHM-1. This is due to weight growth and movement of the center of gravity. Control

of the weight and center of gravity of a hydrofoil ship is absolutely necessary. The proper use of weight margins in the design process is fundamental to a successful design. An overview of the entire weight status of a ship from Preliminary Design through scrapping of the ship is helpful to understanding this process.

Figure 3.2.X is a typical simplified weight history. In the example illustrated, the total weight growth occurring during the ship's service life has exceeded its Design Full Load Displacement, resulting in an overload condition and performance which is below specified levels. This overload condition is frequently the direct result of inadequate comprehension of the various margins shown in the design phases of the ship's history.

The weight critical nature of hydrofoil ships and the relatively small size of the margins that are made available require more precise weight estimation than is common. This requires a greater depth of engineering during the early design phases.

3.2.1 Preliminary Design Weight Margins

3.2.1.1 Margins in Light Ship Weight

The assignment of weight margin values is necessarily a compromise and, thus, a cause of controversy. The desire for large margin values is predicated by the wish to cover all possibilities so that growth during design and construction will not threaten performance. Small margin values are desired because margins increase ship size, with all of the resulting effects.

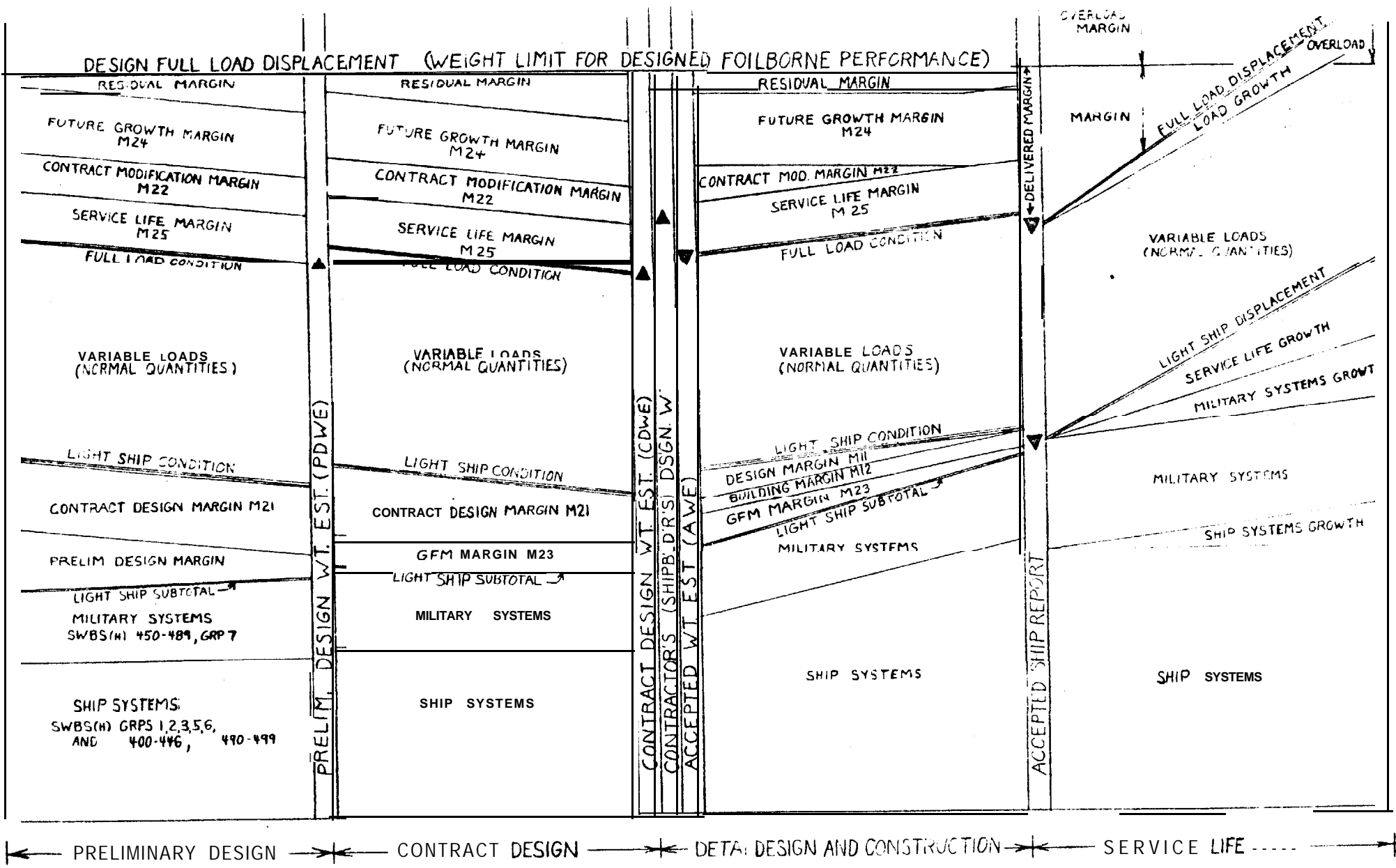

FIGURE 3.2.1 - TYPICAL WEIGHT HISTORY (SIMPLIFIED) FOR A HYDROFOIL SHIP

To some degree, ship design weight estimates represent allowances. It is felt that if, for example, a system is estimated to weigh X tons, that the system designer will design for X tons. Further, if the margin is Y percent, then the designer may design to $(1 + \frac{Y}{100}) X$ tons. Thus, the use of the margin becomes a self-fulfilling prophecy. This is totally understandable, since the designer will be putting in all of the features possible in order to make his system efficient, inexpensive, and reliable. If this thesis is correct, this provides a motivation for minimizing margins.

Some previous hydrofoils have suffered from insufficient margins or inadequate weight prediction. This can result in consumption of part of the Service Life Margin before delivery. This, of course, is bad since the Service Life Margin is not to be depleted during design and construction.

The margins specified for hydrofoil preliminary design are no less than:

Contract Design-----	3%
Preliminary Design-----	7%
Service Life-----	4%
<u>Contract Mbdification-----</u>	<u>1%</u>
Total	15%

The 15% weight margin has been used with some success in the past. However, these margins are considerably less than are often used in conventional ship design. This highlights the need for thorough engineering early in the design.

It is important to note that only the Preliminary Design Margin is to be depleted during Preliminary Design, and this depletion is not to be complete.

3.2.1.2 Margin in Full Load Weight

The Future Growth Margin remains unchanged throughout design and construction.

3.2.2 Contract Design Weight Margins

3.2.2.1 Margins in Light Ship Weight

At the start of Contract Design, the margins are no less than:

Contract Design-----	3%
GFM Margin-----	1%
Service Life-----	4%
Contract Modification-----	<u>1%</u>
Total	9%

The Contract Design Margin may be depleted only to 1.5% during Contract Design. No other margins may be depleted.

3.2.2.2 Margin in Full Load Weight

3.2.3 Detail Design Weight Margins

3.2.3.1 Margins in Light Ship Weight

At the beginning of Detail Design, the margins are no less than:

GFM Margin	-----	-----1%
Detail Design	-----	-----1%
Building	-----	-----0.5%
Contract Mbdification	-----	-----1%
<u>Service Life</u>	-----	-----4%
	Total	7.5%

All margins, except the Service Life Margin and the Building Margin, may be completely depleted during this phase. However, some Contract Mbdifi- cation Margin should be retained for use during construction. Any surplus margin at the end of construction can be used for Service Life Margin.

3.2.3.2 Margin in Full Load Weight

3.2.4 Center of Gravity Margins

It is generally recognized that a ship's center of gravity can be expected to rise during design and construction and during service. Experience on PHM and AGEH also indicates movement of the center of gravity toward the secondary foil system

The margins in Light Ship Weight are each assigned center of gravity locations. Mbst of these can be fairly well controlled during the design and construction process and thus have two percent (2%) center of gravity margin values. However two of them, the Service Life Margin and -the Contract Mbdifi- cation Margin, cannot be controlled during design and construction. They have ten percent (10%) center of gravity margin values.

If the weight margins described in this section were used with these center of gravity values, it would result in a rise of Light Ship KG of about one inch and a longitudinal movement of LCG of about four inches.

As a percentage basis this is a KG rise of less than one percent of the estimated ship KG. This is at about the 20th percentile of KG increase experience for conventional ships.

Because these values are smaller than would be used for conventional ships, this area also requires more precise design.

3.3 ENVIRONMENT

U. S. Navy ships can be expected to operate in all conditions, and in all parts of the world. Unlike merchant ships, they cannot depend upon routing to permit them to avoid unfavorable conditions. This is especially true of hydrofoil ships because one of their advantages is the ability to operate well in poor weather. Thus, they must be designed for extremes.

The conditions described in this section are those in which the ship operates. The equipment within the ship may operate in either more severe or better conditions. Those conditions are covered in the discipline volumes.

3.3.1 TEMPERATURE, HUMIDITY, AND BAROMETRIC PRESSURE

Reference , Atlas of Naval Operational Environments: Natural Marine Environment, describes conditions in nine areas where U. S. Navy ships can be expected to operate. An examination of these conditions led to the extreme conditions shown as requirements for ship operation. The rated conditions represent an approximate average of the 95 percentile of the worst condition. (The exception is air temperature which bounds the 95 percentile).

It is most important that a hydrofoil ship have sufficient thrust to permit it to take off. There have been cases in which this has not been possible due to air temperature. This led to the take-off thrust requirement. The thrust margin should be available in the rated conditions. However in the extreme conditions, it is assumed that the ship can maneuver during its take-off run to permit take-off even if the thrust margin is not available.

3.3.2 SEA STATE

The **Bretschneider/ISSC two-parameter sea state spectrum formulation is used. This is considered to be superior to the single-parameter spectra.**

The **single-parameter spectra are based solely on significant wave height. They are only applied to fully-developed seas.**

The **Bretschneider/ISSC spectrum is based upon significant wave height and significant wave period. It can be used for building, full-developed, and decaying seas. The building and decaying seas together form the majority of conditions most likely to be encountered.**

These facts led to the recommendation of this formulation in the **Naval Sea Systems Command's Seakeeping in the Design Process (Reference)**.

3.3.3 WIND SPEED/DIRECTION

The **ship must be capable of operating in the winds associated with its sea state. These winds may come from any direction and the ship may be maneuvering.**

The **most disadvantageous wind direction for powering, for example, may be different from that for control or other aspects. Thus, each case must be dealt with individually.**

3.4 STATIC STABILITY

In general, the static stability criteria for hydrofoil ships are the same as those for conventional ships.

When hydrofoil ships operate at sea, they invariably do so with their foils extended. This is for improved seakindliness, control, and, in some cases, performance. The foils are only retracted when in shallow harbors or for in-port maintenance. This has been the case for PHM. Therefore, it is an unnecessary encumbrance to require unlimited "ocean" criteria with foils up.

Because methods exist which permit rapid calculation of Center of Lateral Resistance (CLR) of a foil system, this detailed calculation shall be made. Since struts in a pi or three-strut system are quite far apart, shadowing should not be assumed in the calculation.

3.5 MATERIALS AND MANUFACTURING TECHNOLOGY

The selection and control of materials for hydrofoil structures and components has progressed to the point where the criteria covering these aspects have been prepared. The criteria established herein are based on varying levels of justification relating to the service experience gained from the hydrofoil ships built to date and similar material applications in a marine environment. In general, the performance of the materials has been satisfactory; however, in specific instances, a poor selection of material was made, the design did not account for the rigors of the marine environment, or the processing and inspection procedures were not adequate to prevent failure.

This section contains the background information for the materials criteria based on the present state-of-the-art. This information was obtained from Reference and supplemented by additional data from other sources.

3.5.1 GENERAL

3.5.1.1 MATERIAL SELECTION

Reference reviewed the material selection procedure for advanced high performance ships. It was found that there had been no consistent set of guidelines or criteria for material selection which has resulted in a wide variety of materials in use. Understandably, some poor choices were made due to lack of information on loads, environmental conditions, material characteristics, etc.

Past experience with a number of programs including hydrofoils has shown that failures will occur unless the proper materials and processes are combined with adequate designs. Hydrofoil examples include:

- a) Fatigue cracking in PGH-2 struts (Reference) and PHM1 foils
- b) Stress corrosion of the Bras d'Or foils (Reference)
- c) Exfoliation and stress corrosion of AGEH and PGH-2 hull plates (Reference)
- d) Fatigue cracking of PHM1 "Y" duct
- e) Cavitation and fatigue of propellers (AGEH and PCH) (Reference)
- f) Corrosion of AGEH linkage components (Reference)
- g) Exfoliation corrosion of 5000 series aluminum rivets on PGH-2 and PHM1

This specification requirement to justify material selection was based on the need to review the system requirements and potential failure modes so that the most cost effective and efficient material selection can be made.

3.5.1.2 STANDARDIZATION

Standardization is necessary for two main reasons: 1) to save costs by reducing the types and sizes of materials and parts required, and 2) to minimize the possibility of potentially dangerous assembly errors by using the wrong size or type of material.

3.5.2 METALLIC MATERIALS

3.5.2.1 PROCUREMENT SPECIFICATIONS

Adequate specifications are required to maintain control of material design properties. Specifications should be supplemented by additional purchase

order requirements when unique properties are desired (e.g., most titanium specifications do not cover ELI or marine grades and beta annealing). In all cases of supplemental requirements or deviations, records should be maintained to document the actual material requirements used.

3.5.2.2 Mechanical and Physical Properties

Material design allowables should be specified and calculated in a uniform manner so that accurate trade-off comparisons can be made between different materials and designs. In addition, they significantly affect the reliability and safety of designs.

3.5.2.3 PROCESSING

The fabrication processes applied to a material can significantly affect their performance and should be controlled. In those cases where specifications are not available or adequate, the procedures used should be documented for reference in evaluating the material performance.

3.5.2.4 LIMITATIONS

3.5.2.4.1 Low Alloy Steels

- a) Organic coatings have historically provided the most cost efficient corrosion protection for steel alloys in sea water (References , , and). Metal coatings that are more noble than the steel such as nickel, chrome or lead will cause severe attack of the steel at any break in the

cladding or plating. The anodic coatings such as aluminum or zinc will provide short term protection by corroding preferentially to the steels.

- b) The HY steels are subject to embrittlement if stress relieved (Reference). If stress relief is considered mandatory, special procedures are required to minimize the potential for embrittlement.
- c) Decarburization and untempered martensite can lower the fatigue life of 4000 series steels significantly by creating either a soft or hard surface on the component.

3.5.2.4.2 Corrosion Resistant Steels

- a) It has been recognized that the corrosion resistant steels (300 series and the PH grades) are susceptible to crevice corrosion in quiescent sea water (References and). This is due to the formation of an oxygen concentration cell that makes the crevice area anodic to the outer surface. Very rapid attack is possible under these conditions (1/4 inch in a month). Adequate velocities that mitigate the crevice effect break up the oxygen cell and prevent the attack.
- b) Test data are available that show hydrogen embrittlement of the PH steels can occur due to overprotection. Voltages generated by zinc anodes (-1.04 volts - Ag/AgCl reference cell)

caused cracking in 17-4 PH at lower stress intensities and shorter times than for material that was not cathodically protected (References and).

3.5.2.4.3 Aluminum Alloys

- a) Exposure of the aluminum alloys to elevated temperatures will overage and weaken the heat treatable aluminum alloys 6061 and 7075 and will sensitize the 5000 series to corrosion (Reference).
- b) The 7075 alloy is marginal for marine use because of its poor corrosion resistance. The T73 condition is not susceptible to stress corrosion cracking and may be used where the application would not be exposed to the marine environment. The 7075 alloy is not considered weldable.
- c) Aluminum alloys are anodic to steels, titanium and nickel base alloys. Galvanic couples may develop between the aluminum and the more cathodic materials causing serious corrosion of the aluminum. Because of this, the aluminum should be insulated from the cathodic materials. (See ML-STD-889, Reference).

3.5.2.4.4 Titanium Alloys

- a) The toughness and stress corrosion resistance of Ti6 Al-4V and Ti 6Al-2Cb-1Ta-1Mo are related to their microstructure and oxygen content (References , and) (in general, the lower the oxygen content, the higher the toughness). The

marine grade has a maximum oxygen content of .08 to .11%, the ELI grade a maximum of .13% and the standard grade .20%. In addition a beta annealed structure provides a higher toughness than an alpha-beta structure. It must be understood; however, that the higher toughness is obtained with a reduction in tensile strength.

- b) Titanium alloys are susceptible to oxygen and nitrogen pickup on the surface if heated above about 1000⁰F in the presence of these gases. The surface contamination results in a hard brittle surface layer that lowers the fatigue life and increases susceptibility to sustained load cracking.

- c) As discussed earlier titanium is cathodic to steels and aluminum and a galvanic couple will be established if the materials are electrically connected. In any galvanic couple the anodic material will tend to corrode (see ML-STD-889, Reference).

3.5.2.4.5 Nickel Alloys

See 3.5.2.4.4c (above) Nickel alloys are galvanically similar to the titanium alloys.

3.5.2.4.6 Copper Alloys

- a) It has been found that the corrosion resistance of the CuNi alloys is related to the velocity of sea water in contact with

the material (Reference). At the critical velocity for each alloy the surface oxide is removed resulting in rapid corrosion of the alloy. The critical velocity for the 90-10 and 70-30 alloys varies with chemical composition and tube diameter such that the 12 ft/sec. requirement is generally a conservative figure.

b) The copper alloys will cause corrosion of aluminum similar to nickel and iron and contact between the two materials in a marine environment must be avoided.

3.5.3 NONMETALLIC MATERIALS

3.5.3.1 COATINGS

3.5.3.1.1 Usage

Coatings for hydrofoil struts and foils have been under study since the first Navy boats were built (see Table 3.5.1). These studies are still in progress with test strut/foil coatings being evaluated on PCH-1 at the present time. Results to date indicate that PR-1654 and Plasite 7133/7155 systems have performed effectively and will achieve the required life with minimum maintenance. Both "cosmaline" and "Floatcoat" type coatings have been used to protect the interior of struts and foils. Additional experience is needed to quantitatively evaluate their corrosion protection life and their effects on repair welding.

For exterior hull coatings, numerous systems have been used (Reference). The hull coatings have been acceptable from a corrosion protection standpoint with the primary limitation being the antifouling

TABLE 3.5.1 - COATING USAGE HISTORY

	Type	Comments
STRUT/FOIL		
<u>External</u>		
Laminar X500 4-(X)-78 Cermet	Polyurethane	Has suffered brittle failure in impact areas -- other performance good.
PR 1654	Polyurethane	Good performance -- will suffer some damage under severe impact or cavitation conditions.
Plasite 7155/7133	Epoxy	Good performance in limited service experience.
Laminar X500 Teflon Filled	Polyurethane	Should have better flexibility than aluminum filled. Little service data as of July 1977.
<u>Internal</u>		
Cosmoline and Texaco Floatcoat		Have performed satisfactorily for periods up to 1 year.
Vapor Phase Inhibitor and Magnus-Maritec Sulfate		NAVSEC recommendation.
H U L L		
Navy formula 117/120/121	Vinyl	Good performance -- anti-fouling effectiveness limited to approximately 1 year.
Devran	Epoxy/Vinyl	Good performance -- minimal fouling in 18 months (intermittent immersion). Navicote susceptible to erosion damage under severe conditions.
Porter Tarsat primer/coal tar	Epoxy	Good performance -- anti-foulant limited to approximately 1 year.
Alodine/MIL-P-23377/ Andrew Brown Colortex	Epoxy/Vinyl	Excellent performance on commercial hydrofoils. Anti-fouling performance good for periods of 1000-3000 foil-borne hours (approximately 6 to 18 months) dependent on the frequency of cleaning and the geographic location.

performance. In general, the antifouling capability was limited to 12 to 18 months. In addition, the Navicote used on PHM showed erosion damage after 453 hours of foilborne operation. The Andrew Brown Colortex has shown excellent erosion resistance on the commercial JETFOILS for up to 3000 foilborne hours (approximately 18 months) to date; however, when the boats are not cleaned frequently (weekly) some operators recoat every six months to maintain the anti-fouling characteristics. Some of the newer materials and concepts such as the Glidden No-COP or the integral antifoulants show promise, but do not have established lifetimes in operational service.

For exterior decks standard Navy nonskid paints (MIL-D-23003 Type II) are marginal because of adhesion problems due to the flexibility of the aluminum decks and the criticality of the surface preparation prior to coating. References , and contain detailed information on the past performance of coatings.

3.5.3.1.2 Life Expectancy

The hull interior coatings are standard applications for Navy ships and offer no unique problems (Reference). The exterior hull coatings have provided corrosion resistance for 18 to 24 months and should last a minimum of three years with normal touch-up and maintenance. Antifoulants for the hull should provide a minimum of 24 months of protection.

For struts and foils the life expectancy of the newer coatings has not been firmly established; however, the results to date indicate that the 500-hour foilborne required life for the exterior and antifoulant applications

is within the present state-of-the-art (References and). Data on the life of antifoulants for the strut/foil systems is limited, but 500 foilborne hours should be realized.

3.5.3.1.3 Coating Application

The adhesion of protective coatings is dependent on a clean substrate. Numerous instances of coating failures have been related to lack of proper cleaning (Reference).

3.5.3.1.4 Limitations

- a) The Laminar X-500 4- (X)-78, Cermet coating has been used on the struts and foils of PGH-2, the PCH-1 and the AGEH-1. The coating has performed well except where it has been impacted or where there is movement such as at mechanical joints. At these points the cermet cracked and chipped allowing corrosion to take place (Reference). It is not recommended for use on strut/foil systems for that reason.

- b) The PR1654 is being evaluated on the PCH struts and foils. In general its performance has been very good; however, during one drydocking, "Skydrol" hydraulic fluid was allowed to contact the PR1654. The "Skydrol" damaged the coating to the extent that the contaminated area had to be stripped and recoated.

3.5.3.2 SEALANTS AND FAIRING MATERIALS

3.5.3.2.1 Usage

Sealants and fairing materials have had a similar history as coatings for hydrofoil usage. The requirements are based on the best information available and actual service performance of the materials (Reference).

3.5.3.2.2 Application Procedures

To obtain adequate adhesion and properties, sealants and fairing materials require clean surfaces, proper application, and the recommended cure time and temperature. Pot life and shelf life restrictions must be followed. There have been no short cuts found to speed up the fairing operation with the exception of an elevated cure temperature.

3.5.3.2.3 Service Life

Properly applied, sealants should meet the specified life requirements.

3.5.3.2.4 Limitations

Sealants do not develop maximum adhesion until they have been cured for the specified time.

3.5.3.3 COMPOSITES

Composites are unique structural materials in that they can be made up with different materials and fibers to obtain a variety of properties. For this reason, a procedure is required to document the fabrication of a specific

part such that production control can be maintained. The advanced composites with graphite or boron fibers in epoxy or polysulfone matrices can be fabricated to obtain very high properties; however, they are very expensive. For marine use, graphite fibers would be preferred because of lower costs. The glass reinforced plastic (GRP) composites also can use different glass fibers for special properties and can be designed for specific components. GRP has been used for small nonstructural parts on hydrofoils (pods and fairings). The primary operational problem associated with the use of composites has been load transfer into the composite either through mechanically fastened or adhesive bonded joints. For this reason, component tests should evaluate not only the part but also the load transfer into the adjacent structure.

3.5.3.3.1 Selection of the Composite Material

3.5.3.3.2 Procurement Specifications

3.5.3.3.3 Properties for Structural Design

3.5.3.3.4 Limitations

Similar to the compatibility problem of aluminum with titanium graphite is a very cathodic material and will cause serious corrosion of aluminum if an electrical circuit is established.

3.5.3.4 HYDRAULIC FLUIDS

The selection of hydraulic fluids is a compromise between fire resistance and corrosiveness. The MIL-H-5606 is compatible with most materials and finishes but is the least fire resistant. The "Skydrol" type materials are

the most fire resistant, but are highly corrosive to some materials and finishes. The ML-H-83282 is the recommended fluid because it is compatible with most materials and has acceptable fire resistance.

3.5.3.5 LUBRICANTS

3.5.3.6 TRANSPARENCIES

3.5.3.7 THERMAL AND ACOUSTIC INSULATION

The insulation materials called out in the General Specification (Reference), are generally adequate for conventional ships; however, hydrofoils are weight critical and light weight insulation is desirable. The NAVSEC 6101 study investigating insulation materials to protect aluminum ship structures has found that some light weight materials do give adequate protection (Reference). The results of this study should provide a lighter insulation for the fire protection of hydrofoils.

3.5.4 FASTENER MATERIALS

3.5.4.1 STRUTS AND FOILS

The use of fasteners has been a compromise between strength, corrosion resistance, compatibility and costs. For alloy steel structures, the low strength austenitic (300 series) stainless steel or the A286 can be used. Alloy steel fasteners have been used but maintaining a corrosion protection coating has been difficult. The 300 series stainless steel fasteners can be used where the structure is coated and subject to intermittent sea water exposure. For stainless steel S/F components, A286 is preferred since it is quite resistant to crevice attack and it is intermediate in cost. Crevice attack has been noted where A286 is in contact with itself or more cathodic

materials such as titanium The 300 series or alloy steel are subject to crevice and general corrosion under similar conditions. The only fastener materials compatible with titanium are titanium and MP35N.

3.5.4.2 HULL

Of the available aluminum alloy rivet materials, 6061 has proven to be the most corrosion resistant with relatively high strength. The 5056 rivets were found to fail by exfoliation corrosion on PGH-2 and PHM

For threaded fasteners, the 300 series and A286 provide adequate strength and corrosion resistance for internal and external applications respectively. The A286 fasteners should be insulated from the aluminum when subject to immersion.

3.5.4.3 LIMITATIONS

- a) Experience with operating boats such as PGH-2 and test programs (Reference) has shown the 300 series stainless steel fasteners to be highly susceptible to crevice attack when used with stainless steel, titanium or composite components.
- b) See 3.5.4.2 above.
- c) A286 fastener material has performed very well with stainless steels, aluminum and GRP; however, in contact with itself, titanium and Inconel 625, the A286 has suffered crevice attack.

3.5.5 COMPONENT APPLICATIONS

The information in this section is primarily taken from Reference and supplemented from other sources.

3.5.5.1 STRUTS AND FOILS

General

A progression of increasingly complex and higher strength materials have been used in hydrofoil struts and foils since 1970 (see Table 3.5.2). These are:

1960-1965: **HY80, HY100 Steels**

1965-1970: **AL 6061 + 4340 Steel, 17-4PH Steel**

1970-1976: **HY130, 15-5PH, 17-4PH Steels**

Promising candidates have been in development since the mid-60's and may be available for construction of larger hydrofoils:

1978-1984: **Titanium Alloys**

1985-1990: **High Strength Composites**

Confidence has been gained in the use of HY80, HY100 and 17-4PH/15-5PH steels. Preliminary design of HY130 struts and foils for the PHM has been completed and the detailed design and construction of a HY130 tail strut for the AGEH is complete.

TABLE 3.5.2 - STRUT AND FOIL MATERIALS

CRAFT	ALLOY	FORM	APPLICATION
PCH-1	HY-130 HY-80 Steel	Sheet, Plate Sheet, Plate	Aft Struts Struts, Foils
ACEH-1	KY-80 Steel HY-100 Steel HY-130 Steel	Sheet, Plate Sheet, Plate Sheet, Plate Forging	Strut, Foil Foil, Skin Aft strut
DENISON	AISI 4130 Steel AL5456-H321 AL7079-T611 HY-S0 Steel AISI 4130 Steel	Sheet, Plate Plate Forging Sheet, Plate Plate	Forward Struts and Foils Aft Pod Skin Aft Foil Struts Struts
PGH-1	4330 Modified Steel *Fiberglass AL 6061 T 653	Casting Laainste Forging	Support Fittings Main Foil Pods Strut Leading Edges Foils
PGH-2	17-4PH-H950 17-4PH-H950	Sheet, Plate Wrought	Struts Foils
FHE-400	18Ni tlaraging Steel 2.50 CVM 18Ni Maraging Steel 250 CVM Inconel 718	Sheet, Plate Forging Forging	Struts, Foils Internal Fittings Strut and Foil Leading Edges
PHM-1	17-4PH (H1100)	Plate	Struts and Foils

*Initial pods were welded and riveted AL 5456-H321 plate

The following general attributes are important overall material considerations:

Cost

Strength to Weight Ratio

Ease of Fabricability - amenable to shipyard practices

Ease of Repair - amenable to shipyard/field repair

Distortion - minimum during fabrication

Availability - routinely produced to military/commercial specifications

Corrosion Resistance - for both continual and intermittent exposure

Fracture Toughness and Fatigue

Susceptibility to Environmental Degradation

Obviously the design process allows some give and take with these properties, especially as a function of ship size. For example in ships of less than 100 tons, solid machined foils have been very successful and welding is not a primary factor. In large ship sizes (500 tons) strength to weight ratio is more critical. With hydrofoils involving non-retractable foil systems, the corrosion behavior is paramount.

The mechanical properties and other characteristics of the materials discussed are listed in Tables 3.5.3, 3.5.4, and 3.5.5.

Materials in Use

- 1. Aluminum 6061 (Foils on PGH-1)**
 - Solid machined foils**
 - Requires coatings**
 - Excellent choice for small (100 ton) ship**
 - 900 hours foilborne service as of March 1976**

TABLE 3.5.3 - TYPICAL MECHANICAL PROPERTIES OF ALLOYS

Grade	Yield Strength (ksi)*	Tensile Strength (ksi)*	% Elongation in 2 in.	% Reduction in Area	Charpy Vee Notch (ft-lbs @ R.T.)†
<u>Steels</u>					
HY 80	88	103	27	70	100
HY 100	100	120	22	65	
HY 130	140	150	21	65	50
<u>Maraging</u> 18 Ni	184	191	15	65	60
17-4 PH	150-170	155-175	14-20	58-64	13-50
15-5 PH	150-170	155-175	14-20	58-64	13-50
<u>Titanium</u>					
Ti-6211	110	125	12	30	40
Ti-6-4	120	135	12	25	20
<u>Nickel</u>					
Inconel 718	147-175	150-200	12-24	15-30	50-25
Inconel 625	60	120	50	48	

* 1 ksi = 1,000 psi

† R.T. = room, or ambient temperature

TABLE 3.5.4 - FATIGUE PROPERTIES OF METALS

Grade	Fatigue Smooth Air	Strength ¹ (ksi)* SRW ²	@ 10 ⁸ Notch Air	cycles (ksi): SRW
<u>Steels</u>				
HY 80	42	9	20	4
HY 100	66	12	16	4
HY 133	67	9	43	4
<u>Maraging</u>				
18 Ni	6.5	7	35	4
17-4 PH ³	60	20	30	10.
-	-	-	-	-
<u>Aluminum</u>				
5 4 5 6	20	< 5	16	< 5
<u>Titanium</u>				
Ti-6211	38	40	20	20
Ti-6-4	55	55	38	35
<u>Nickel</u>				
Inconel 718	84	25	25	20

¹ Rotating Cantilever Specimens, 1,450 cpm

² SRW - Severn River Water. Past experience has shown this usually has the same effect as seawater. (See text)

³ Base metal only ST + Aged at 1,135°F, weld results inconclusive.

TABLE 3.5.5 - TYPICAL CORROSION CHARACTERISTICS, COST, AND MODULUS OF ALLOYS

Grade	Cost	Modulus, E, in psi	Corrosion Resistance			
			General	Stress Corr. Cr.	Pitting and Crev.	Erosion & Cavit.
<u>Steels</u>						
HY 80	55 ¢/lb.	29x10⁶	Fair (Uniform)	Good	Fair to Poor	Poor
HY 100	60 ¢/lb.	29x10 ⁶	Fair (Uniform)	Good	Fair to Poor	Poor
HY 130	75 ¢/lb.	29x10 ⁶	Fair (Uniform)	Good	Fair to Poor	Poor
<u>Maraging</u>						
18 Ni	\$3.50/lb.	28x10 ⁶	Fair to Good	Bad	Good	(Fair?)
17-4 PH	\$2.50/lb.	28x10 ⁶	Good	Good	Very Bad	Good
<u>Aluminum</u>						
5456	60 ¢/lb.	10.3x10 ⁶	Good	Good	Fair	Bad
<u>Titanium</u>						
Ti-6211	\$8-10/lb.	16x10 ⁶	Excellent	Excellent	Excellent	Excellent
<u>Nickel</u>						
Inconel 625, 718	\$5-6/lb.	30x10 ⁶	Good	Good	Fair	Good

2. **High Strength Steels (4330, struts on PGH-1)**
(18 Ni Maraging, Struts and foils on FHE-400)

- **Require coating**
- **Susceptible to stress corrosion cracking in the welds**
- **Low toughness**
- **Not being pursued as strut/foil candidate**

3. **HY80**

(3% Ni-1½% Cr), (Struts and Foils on PCH Mbd 0)

(Strut/Foil Frames on AGEH)

- **Welding and fabrication procedures well in hand**
- **No major structural cracking or other materials/fabrication problems after 1207 hours of service**
- **Demonstrated repairability in the field and compatible with shipyard practice**
- **Requires a coating**
- **Limited yield strength, therefore, as ship weight increases it becomes a less viable candidate**

4. **HY100**

Similar composition to HY80, but plates are heat treated at the mill, (Strut/Foil Plates on AGEH)

- **Same comments as HY80**
- **Due to adequate yield strength, this alloy remains an attractive high strength steel candidate**

5. **HY130 (5% Ni)**

a) PCH-1 Mbd 1 Used in Combination with HY80

The major strut/foil modifications to PCH-1 in 1970-1972

involved significant changes to the strut/foil system. Portions of the new struts and foils were designed for HY130 material by the Boeing Company and fabricated by a local subcontractor. No major problems have been encountered in the 522 foilborne hours since modifications were completed.

b) Preliminary Design for PHM Struts and Foils

In 1973, the Grumman Aerospace Corporation was contracted to complete preliminary design of a ship-set of PHM struts and foils made of HY130 material. The overall guidelines required that the weight and configuration of the new structure be identical to the existing 17-4PH structure. The important output of this work consisted of:

- Consideration of the unique problems associated with the "water box" up the struts (PHM is waterjet driven).
- Internal and external corrosion protection
- Development of a Fabrication Document, consistent with existing Navy documents
- Procedures to maximize internal weld inspectability
- Weld sequencing and other techniques to minimize distortions
- Development of procedures to maximize structural integrity

c) Design and Fabrication of an HY130 Tail Strut for AGEH

The design and fabrication of this structure, completed in 1974, has incorporated all prior HY130 experience and particularly has validated the preliminary design work accomplished in b) above. The significant points from this work include:

- Validation of a fabrication procedure
- Realistic appraisal of the contour tolerances achievable
- Confidence and experience of the manufacturer in the use of HY130. This will be reflected in cost reduction in future HY130 construction due to the elimination of risk. Due to the uniqueness of this one-of-a-kind strut, extensive hand welding was used. For multiple unit manufacturing, additional tooling and automated welding would be utilized. This saving is estimated to be 15 to 20% and does not include the cost reductions due to being higher up the "experience curve."

d) In summary of HY130 for struts and foils, the material exhibits these characteristics:

Favorable

- Desirable mechanical properties (particularly strength)
- No heat treatment required with resultant:

Relatively low amount of rework, cost and distortion, compared to PH steels (Note: See Section 6c)

Field Repairability

Unfavorable

- Weak industrial base (Navy submarine use is other primary use)
- Requires protective coating

6. 17-4PH Stainless Steel

a) H950 Condition - Struts and Foils on PGH-2 TUCUMCARI

The foils were solid machined 17-4PH steel and the struts were a combination of 17-4PH and 304 stainless steel (inadvertently used in manufacture). This craft had a service life of 1200 foilborne hours before her grounding and subsequent scrapping. The strut/foil system was examined in detail and the flaws categorized to service related and grounding related. Significant findings from PGH-2 include:

--- The grounding on a submerged reef at 40 knots caused surprisingly little personnel injury (several crew members hospitalized for about one week). The forward strut took the majority of the impact and collapsed all of the aluminum structure in its path. It did however, remain intact and connected to the hull at its yoke.

--- There were numerous pre-existing fatigue cracks. In many cases these were associated with the low strength 304 stainless steel/17-4PH welds. In some instances cracks were associated with section discontinuities (e.g., thick to thin plate welds) or weld defects. The few major cracks found have been attributed to both of these causes.

--- Stress corrosion of this sensitive alloy (H950) condition was not a major problem although one SCC crack was found at the strut/foil connecting lug roots.

--- There was some localized corrosion of the 304 stainless steel weld and adjacent plate, but no severe pitting or crevice attack at the many numerous potential sites.

--- 303 stainless steel and high strength steel bolts corroded but A286 steel bolts were intact.

The significant lessons learned from PGH-2 were applied to the PHM program include:

--- Control of material during fabrication

--- Attention to design and fabrication detail is mandatory

--- Localized corrosion of 17-4PH steel is not a problem due to foil retraction and natural repassivation

--- Use A286 fasteners in 17-4PH steel plates

b) 17-4PH Steel (H-1100 and Direct Age, PHM 1)

This alloy was selected for PHM based on its strength, corrosion and fatigue resistance and its successful application on PGH-2.

It was quickly recognized that the heat treatment of this highly complex alloy would create difficulties in distortion and possible quench cracks at uninspectable locations. A major effort was conducted to analyze and simplify weld

joints, particularly "blind" ones. This was pursued such that the level of detail now in the PHM1 strut/foils is higher than in any previous system. To achieve adequate toughness and overcome heat treatment difficulties the strength allowable for PHM1 was reduced from 130 ksi to 100-110 ksi yield. This strength level was achieved by using only a direct aging treatment at 1100⁰F after welding.

If a full heat treatment of 17-4PH is required, it poses these difficulties:

- Lack of available furnaces (for PHM strut only one large enough in U.S.)**
- Distortion, quench cracks and associated rework**
- Handling difficulties in and out of furnace**
- Limitation on piece size has impact on applicability to larger ships.**

The complexity of this alloy requires close processing control. Minor heat treatment variables, alloy chemistry variations, and plate surface treatment cause, for example variations in laboratory corrosion behavior. Recent experience in the Boeing Commercial JETFOIL (which uses 15-5PH steel, an alloy with a chemistry specification overlapping 17-4PH) indicate that continuous immersion can cause corrosion attack. This leads to the possibility that 17-4PH steel may require a protective coating for constant immersion applications which obviates one of its prime advantages.

c) In summary, the following factors would indicate that 17-4PH (at 130 ksi yield) is a less viable strut/foil candidate than HY130 for large ships:

- Possible need for coating on 17-4PH
- Heat Treatment
- Field Repair

It should be noted; however, that recent studies have shown the use of direct aged or as welded 17-4PH/15-5PH using 347 filler wire minimizes the heat treatment and field repair disadvantages and with adequate cathodic protection the pitting and crevice corrosion can be controlled. These factors plus the superior fatigue properties should be considered when comparing 17-4PH/15-5PH to HY130.

7. 15-5PH Stainless Steel

15-5PH is an alloy that has a chemistry specification which overlaps that of 17-4PH steel; however, it has the advantage of only being in a vacuum melt condition. It has been used in the Boeing Commercial Hydrofoil, JETFOIL, and performance to date has been the same as would be expected of 17-4PH. In general this alloy has similar characteristics to 17-4PH steel and has performed acceptably; however, there has been pitting in continually submerged areas. One of the reputed advantages of 15-5PH is the elimination of ferrite with more short transverse toughness. However, some heats have been found to contain small amounts of ferrite. The cracking that has occurred so far in JETFOIL foils has been due to overstress conditions rather than an inherent metallurgical problem

8. Other Candidate Materials

a) Titanium

This attractive material has been considered for strut/foil applications for over 10 years. Funding limitations have prevented the development of detail structural analysis and fabrication.

Advantages include:

- High strength to weight ratio
- Corrosion fatigue characteristics
- Corrosion resistance

Areas of concern include:

- Low modulus and resultant flutter potential
- Oxygen protection at the backside of inaccessible welds
- Field repairability

Present activities in research include:

- Significant spin-off in titanium technology from the hull plate program
- Initial design analysis regarding the effects of low modulus on the dynamic characteristics of struts and foils
- Preparation of box beam specimens, (see paragraph, Laboratory Evaluation No. 1 below)

b) Advanced Composites

These materials utilizing graphite or boron fibers are also attractive candidates and have been studied extensively

for hydrofoil application. Current research and development involve:

- Material properties in marine environment
- Load transfer techniques
- Definitions of cost/benefit payoffs for hydrofoil applications
- Detail design and construction of two box beams (see paragraph, Laboratory Evaluation No. 1 below)
- Detail design and construction of two flaps for PCH-1 Mbd 1 service and laboratory evaluation

c) Clad HY130

An interesting possibility under study to improve the corrosion resistance of HY130 steel involves roll cladding the steel plates with a nickel base alloy (Inconel 625) prior to fabrication.

- The materials are weld compatible
- Production feasibility of composite plate has been demonstrated
- Mechanical properties of HY130 base plate (with cladding) and welds are satisfactory
- HY130 steel plate heat treatment does not affect Inconel 625 corrosion properties
- Corrosion and corrosion fatigue of Inconel 625 are excellent

This approach would use the HY130 plate as the structural member and the Inconel 625 cladding for corrosion protection. There is further work required with regard to forming and detailing of the composite weld joint.

d) Castable Polyurethane on a Steel Substrate

A novel approach to strut/foils concerns fabricating a steel shape without regard to contour and distortion and then casting the hydrodynamic surface on it. The substrate can be a crude shape designed for strength and ease of fabrication with attendant performance and cost-saving benefits. Over this fabricated structure is cast, to required hydrodynamic contour, a polyurethane compound ranging in thickness from 1/8 to greater than 2 inches, which will provide corrosion and impact resistance.

Laboratory Evaluation

1. Hydrofoil Tapered Box Beam Program

Although small laboratory coupon testing is useful as a screening process, a more meaningful material evaluation can be achieved from test on fabricated sections. For this reason a specially designed test segment of a strut/foil system called a tapered box beam was designed. This (5' X 2' X 4") section simulates (four cells created by an interesting rib and spar) a typical foil section. The plate thickness and structural details are representative of a typical hydrofoil ship. The fatigue loading spectrum has been derived from actual trial data tapes and the environmental conditions have been chosen to simulate the sea conditions profile that would be encountered in 10 different locations in the world. Assuming an operational requirement for 1,000 foilborne hours per year, then a 15-year life would represent approximately 7.5×10^6 cycles.

This program, which was initiated in FY 1972, originally consisted of 8 different box beams using different materials and methods of box closure as described in Table 3.5.6. Since then, a titanium box beam has been fabricated using electron beam welding, and an advanced composite box beam is planned. The status as indicated by the cycles to date is also shown. As can be seen, the program is still in testing, but information of fabrication cost, fabrication distortion, weld repair techniques, and fatigue life have been obtained. The relative cost of each of the eight box beams is shown in Table 3.5.7. The relative fabrication cost in order of increasing cost would be HY80 slot weld, HY130 slot weld, 17-4PH either configuration and HY130 patch configuration.

Even though the Hydrofoil Tapered Box Beam Program is not complete, certain conclusions can be made at this time. All experimental results and conclusions drawn from them are dependent upon the assumptions used in designing the box beams and in developing the load spectrum. Comparison of materials and fabrication details is based on testing of the box beams to the same percentage of material yield strength. Those conclusions offered at this time are:

- Box beams with slot weld configurations have the best adherence to tolerances**
- HY80 is the least expensive material to fabricate, followed by HY130 and then 17-4PH**

TABLE 3.5.6 - SUMMARY OF BOX BEAM STATUS

(Box beams tested to the same percentage of material yield)

Box Beam #	Material	Method of Weld Design Closure	Test Environment	Status Cycles to Date
1	H-1 80	Slot Geld	Air	Static Failure*
2	HY 80	Slot	Salt Water	7.631x10 ⁶
5	HY 80	Closure Patches	Salt Water	9 106x10 ⁶
4	HY 80	Slot	Air	10.404x10 ⁶
5	H-f 130	Closure Patches	Salt Water	4.00x10 ⁶ **
6	HY 130	Slot	Air	2.146x10 ⁶ ** --
7	17-4 PH	Tee	Salt Water	In Testing
8	17-4 PH A	Closure Patches	Salt Water	In Testing
9	Titanium		Salt Water	In Testing
10	Advanced Composite		Salt Water	In Design

* @ 190,000 cycles.

** In testing.

TABLE 3.5.7 - APPROXIMATE RELATIVE COSTS BOX BEAM

Box Beam	Material	Configuration	Facility	Approximate Cost
1	HY 80	Slot	A	N
2	HY 80	Slot	A	.6N
3	HY 80	Patch	B	1.4N
4	HY 80	Slot	A	.4N
5	H-f 130	Patch	B	1.7N
6	HY 130	Slot	A	N
7	17-4 PH	Tee	C	1.3N
8	17-4 PH	Patch	C	1.2N

- There is a significant decrease in fabrication cost once manufacturing experience has been gained.
- Based on the results to date for uncoated foils, minor fatigue cracks are inevitable in the operating life of the foil. A program of periodic inspections will be required. Coatings, where required, to protect the foils from corrosion should improve the fatigue life and extend the period between inspection.
- Slot weld configurations last appreciably longer than closure patch configurations.
- HY80 appears to last approximately four times as long as HY130 in corrosion fatigue.
- GTAW in the horizontal position is the best process for repairing box beam type structures.
- Single-sided butt weld repairs (or initial fabrication) made with a backing strap left in place are preferable to unbacked single-sided butt welds from a fatigue standpoint.
- Repair of HY130 after cycling is more difficult than repair of HY80.
- "Ultimate" strength for box beam type structures in the as-fatigued condition can be conservatively predicted based on net section yielding.
- Cumulative damage theory can predict fatigue failure reasonably well for box beam type structures if the as-fabricated condition is well defined.
- Fracture mechanics techniques predict through crack growth very well for box beam type structures but as yet have not predicted first failure.

Assessment of Technology

The materials selection and fabrication of struts and foils has been an evolutionary process involving:

Existing Materials

- Use of existing common materials in simple structures (solid foils, bolted skins)
- Use of all welded construction of robust low strength alloys (HY80)
- Use of all welded construction of high strength available material (17-4PH stainless steel)
- Use of all welded construction of newly developed alloy (HY130)

From this point advances in material strut/foil technology will be aimed at:

Cheaper, Low Maintenance Materials

- Use of integral cladding materials
- Use of robust skeletons with nonmetallic overlays

Higher Performance Materials

- Use of titanium
- Use of high strength composite materials

Experience to date has identified additional needs which are being addressed.

- Fatigue and fracture control**
- Attention to design, fabrication, and inspection detail**
- "Engineer" the systems to make them more reliable in fleet operations**

3.5.5.1.1 Linkage Systems

The present mechanical flap control linkage systems are subjected to repetitive high loads (1 cps at 25 ksi) in a sea water environment. Some corrosion fatigue failures have occurred in 4340 steel parts and improperly treated 17-4PH steel parts. It is now clearly recognized that titanium alloys, nickel alloys or 17-4PH are the only materials suited to this application and are being used in PHM and the current modification to AGEH

3.5.5.1.2 Bearings

- a) Control surface linkage bearings are generally self-aligning spherical self-lubricating slider bearings, made with 17-4PH stainless steel. Outer race liners are either a teflon fabric or an injection molded plastic. Balls are either 17-4PH or a 6Al-4V titanium alloy. Control surface hinge bearings are either sleeve or spherical slider bearings with either teflon fabric or injection molded plastic liners. Shafts for slider bearings are generally 17-4PH stainless steel polished to 8 to 16 RHR.**

b) Kingpost bearings are required to carry thrust loads and provide a self-aligning capability to accommodate installation misalignment and kingpost deflections. Three different bearing designs are currently used in kingpost applications. One design is a self-aligning AISI 52100 steel spherical roller bearing with an oil lubrication system. The two remaining designs are self-lubricating slider bearings. Bonded teflon fabric provides the lubrication in the ball bore and on the thrust washer surface. The metal components of slider bearings are fabricated from 17-4PH stainless steel.

3.5.5.1.3 Flaps

These components are usually made of the same material as the foil and are either solid or built-up structures employing ribs, end closures and coverplates. Note: The Boeing Commercial JETFOIL uses solid titanium flaps with 15-5PH foils. No problems have been experienced to date. These items, however, offer a good location for the testing of new concepts and material choices in a realistic service environment (e.g., composite flap program).

3.5.5.1.4 Coatings, Sealants and Fairing Materials

See Sections 3.5.3.1.1 and 3.5.3.2.1

3.5.5.2 HULLS AND SUPERSTRUCTURE

Experience with hydrofoils weighing 60 to 320 tons indicates that the 5000 series aluminum alloys are the most practical hull materials

(see Tables 3.5.8 and 3.5.9). Other potential candidates are listed below but at present they do not appear to offer sufficient improvement to displace aluminum

- Steel - Too heavy since minimum available gauges would not be much less than those of aluminum at present.
- Fiberglass - (conventional) - considered feasible but accounting for stiffness and deflections in design would be a problem. Construction experience is limited in this scale. Final weight comparison is not known, but probably would be higher than aluminum
- Composites - (high strength fibers) - could effect weight savings over aluminum (10-20%) but development cost and fiber costs are too high. For this application it currently has a low priority in NAVSEA Exploratory Development.
- Titanium - Too expensive.

Current hull weight fractions are 15-20%. The emphasis must now be placed on hull fabrication cost reduction. This is directly related to the training and skill level of welders, improvements in welding and other joining processes and design innovation. The driving criteria for shell plating is pressure requirements of 6 to 75 psf (depending on location), thus stiffened aluminum plating (0.125-0.250 inches thick) is utilized. Wherever possible, these are extruded panels, although extrusion sizes are limited to that which can be produced through a 30-36 inch diameter die. Welding of the resultant complex shapes has been successfully accomplished by at least five Aerospace and Shipbuilding companies (Boeing, Todd, Grumman, Tacoma Boat and Peterson Shipbuilding Company) and is well within the state-of-the-art.

TABLE 3.5.8 - HULL AND SUPERSTRUCTURE MATERIALS

Craft	Aluminum Alloy	Form
PCH-1	5456-H321 5456-H311 6061-T6	Plate Extrusion Plate, Shapes
AGER-1	5456-H321, H323, H343 5456-H311	Sheet, Plate Extrusion
DENISON	5456-H321 5456-H311	Plate Extrusion
PGH-1	Honeycomb Deck Panels 5456-H321, H343 5456-H311 Fiberglass	Bonded Sheet, Place Extruded Plate Laminate
PGH-2	5456-H321 5456-H311 6061-T6	Sheet, Plate Extrusion Sheet, Forms
FHE-400	Alcan D54-S 6061-T6 7075	Sheet, Plate, Extrusions Plate Forging, Thick Plate
PIEM-1	5456-H116/H117, H112	Sheet, Plate, Extrusions

TABLE 3.5.9 - TYPICAL MECHANICAL PROPERTIES OF HULL ALLOYS

Alloy	Nominal psi Yield Strength Base/Weld	Ultimate Tensile Strength .2% offset, in psi Base	% Elongation in 2 inches	Shear Stress, σ in psi Base	Modulus of Elasticity, E. psi
5456-H321 and 5456-H116/H117	33,000/26,000	46,000	12	30,000	10.3×10^6
5036-H321 and 5036-H116/H117	23,000/22,000	40,000	8	25,000	10.3×10^6

With regards to large hydrofoil ships (2,500 tons) the material of choice is still likely to be aluminum. In-house (IRAD) and government contract work is presently underway at Bell Aerospace, Rohr, Boeing and Alcoa to develop and optimize the most efficient method of welding these materials.

Either 5086 or 5456 aluminum alloys are used for hydrofoil hulls. These alloys, containing 4 to 5 percent Mg and minor amounts of Mn, Cr, and Fe, are good for general marine use, weldable and do not require heat treatment. The aluminum alloy temper commonly used in the 1960's was high strength H321. However, the discovery of the exfoliation sensitivity of this temper in the "Swift" boats in Vietnam, led to development of new H116/H117 tempers. Unfortunately the H321 temper was used in the hulls of many of the existing hydrofoils and a number of cases of exfoliation attack occurred on both the inside and outside of hydrofoil hull plating. In addition, on the TUCUMCARI (PGH-2) a number of minor deck cracks appeared due to: (a) excessive loading on the thin deck plating which resulted in considerable local waviness, (b) stress concentrations at stiffened frame intersections and prior deck repair welds, and (c) possible stress corrosion of thin H321 temper. In many cases the affected plate was removed in large patches and the exfoliation resistant temper H116/H117 inserted. There has been no reoccurrence of exfoliation of H116/H117 tempers in either service or extensive laboratory evaluation of heat sensitized material.

The mechanical properties of the aluminum alloys used are listed in Tables 3.5.4, 3.5.5, 3.5.8 and 3.5.9. There is no difference in mechanical properties between the old H321 and new H116/H117 tempers. As can be seen, aluminum alloys have low corrosion fatigue strength and require coatings for long term protection against both fatigue and general corrosion attack.

- higher quality casting specifications
- substitution of more corrosion resistant materials such as titanium and nickel base alloys
- epoxy coating of the impeller
- better galvanic isolation

3.5.5.3.3 Water Ducts and Inlets

Operational past and present boats using waterjets, PGH-2, PHM 1, and the Boeing commercial JETFOILS, have used a variety of materials for the water ducts. Cast aluminum inlets, PH steel ducts in the S/F system and fabricated aluminum in the hull have been common. The transition section between the hull ducts and the propulsion system has used cast aluminum, cast titanium, fabricated aluminum, and fabricated Inconel 625. Some compatibility problems have been experienced between the aluminum and the more noble metals. In addition, the aluminum has suffered fatigue cracks and cavitation erosion. Coatings such as PR1654 have been partially successful in protecting the aluminum.

3.5.5.3.4 Bearings

Both rolling element and slide types of bearings are successfully used in current hydrofoils. AISI 52100 steels are used extensively for auxiliary equipment and gearbox rolling element ball and roller bearings. Bearings used in high performance gearboxes are generally class ABEC-5 or ABEC-7 precision bearings. Corrosion protection is provided by oil or grease lubrication depending upon operating speeds.

TABLE 3.5.10 - CRAFT/PROPELLER MATERIAL MATRIX

Craft	Propeller Material
*HF PCH-1, Mod 0	Ni-Al Bronze Manganese Bronze Mn-Ni-Al Bronze Ti 6Al-4V CF3M Cast Stainless Steel CF3 Cast Stainless Steel 17-4 PH Cast Stainless Steel Inconel 718
HF Sea Legs	Ni-Al Bronze
HF MH30	"Aluminum Bronze"
HF PAT20	"Aluminum Bronze"
HFs PT20/59	"Aluminum Bronze"
HF PTS75 Mk III	"Bronze"
HF P46	"Bronze"
HFs Comat (or Koneta)	"Brass"
HF Denison	Ti-6Al-4V CA40 Mod. Stainless Steel
PGs S4 to 101	Ti-6Al-4V CF8 Mod. Stainless Steel Inconel 625
Eagle and Double Eagle	Ti-6Al-4V
HF XGEH-1	Ti-6Al-4V
Bell SEV	Ti-6Al-4V
HF PCH-1	Type 414 Mod. Cast Stainless Steel
HF Dolphin	Type 414 Mod. Cast Stainless Steel
HF Proteus	17-A PH Cast Stainless Steel
HF XCH6 Sea Wings	"Stainless Steel"
HF FHE400 Bras d'Or	Inconel 718

* HF: hydrofoil ship

- The high speed highly stressed propeller technology requires vigorous load prediction and analysis research.**
- The approaches to date are mainly empirical.**
- The most successful applications have used high corrosion fatigue resistant alloys (titanium and nickel alloys) although the stainless steels and bronzes have occasionally been adequate.**
- Cost considerations are forcing the use of castings, where high quality control is essential.**

3.5.5.3.2 Waterjet Pumps

- a) Cast aluminum was used for the waterjet pump housing on TUCUMCARI. The housing was adequate although several weld repairs were performed. The impeller (17-4PH steel) performed satisfactorily (1200 foilborne hours).**

- b) Cast aluminum was used on the PHM 1 pump housing and 17-4PH stainless steel for the impeller. Several problems have developed in the operation so far, related to:**
 - Galvanic corrosion (aluminum housing and steel components)**
 - Inadequate fatigue strength, ductility and quality of the cast aluminum housing**
 - Cavitation damage on the impeller**

These problems indicate that for long term reliability the following factors must be considered in pump design:

The fabrication characteristics of aluminum are deceptively simple. The alloys are soft, easy to machine and form. However, they are deceptive in that they are very easy to weld poorly. The weld properties are most sensitive to weld start-stop crater cracks, cleanliness, gas moisture content and welder skill. Macro and microporosity is easy to entrap and distortions tend to be high in the thicknesses employed due to the low melting temperatures and large heat sink. Experience has shown that it is possible to achieve excellent weld quality in shipyard environments but extreme conscientiousness and care is required on the part of the welders. Specifications exist, but are based to a large extent on steel fabrication criteria. Aluminum fabrication specifications for thin gauges employed in hydrofoils are under review and modification at present.

In short the lessons learned and which are being applied in the PHM program consist of:

- Design simplification
- Rigorous training of welders
- Care and attention to detail while welding

3.5.5.2.1 Coating, Sealant and Fairing Materials

See Sections 3.5.3.1.1 and 3.5.3.2.1

3.5.5.3 PROPULSION COMPONENTS

Many different propeller materials have been used on a variety of hydrofoil and other craft in the last 15 years. (See Table 3.5.10) Conclusions to date are:

A carburizing grade of electric furnace steel is specified for tapered roller bearings used in propeller thrust bearing applications. Oil lubrication is required for these high load, high speed applications.

3.5.5.4 PIPING SYSTEMS

3.5.5.4.1 Hydraulic

Hydraulic lines have primarily used the 300 series stainless steels and the 16-6-9 alloy. These materials have suffered some corrosion in exposed areas but have generally given adequate service. CP Titanium has excellent corrosion resistance and has been used where the severe conditions justify the added cost. Aluminum tubing used in early boats was not adequate.

3.5.5.4.2 Sea Water Systems

Sea water piping on the hydrofoils has used 3003 aluminum, 300 series stainless steel or GRP piping. The aluminum has not been satisfactory and is being replaced with GRP. The stainless steel is subject to corrosion attack but has been adequate for many applications. The GRP piping is relatively new and has performed well to date.

Heat exchanger materials have primarily been 90-10 and 70-30 copper nickel alloys and titanium. There is some concern using the copper alloys in an aluminum boat; however, no major problems have been noted to date.

3.5.5.4.3 Fresh Water Systems

Fresh water piping systems have used aluminum and stainless steel alloys. The alloys included 3003 aluminum and 304 and 21-6-9 stainless steels. Performance of these alloys has been adequate.

3.5.6 MATERIAL ACCOUNTABILITY

4. QUALITY ASSURANCE

4.1 SHIP TESTS

Hydrofoil ships have some requirements that exceed those of conventional ships. These result from its need for weight control, its flight and control systems, and its exceptional maneuverability. They will be outlined in Section 14 of these criteria. It is expected that hydrofoil trials will be significantly more extensive than those for conventional ships.

4.2 MATERIALS TESTS

Hydrofoils use some unusual materials. Often, these are under high loading and in difficult environments. The construction requires great precision and weight control. These materials must be extensively tested and controlled.

4.2.1 MATERIAL INSPECTION PLAN

4.2.2 MATERIAL PROPERTY DATA GENERATION

4.2.3 SEALANT/FAIRING MATERIAL QUALIFICATION

4.2.3.1 Adhesive Strength

4.2.3.2 Erosion Resistance

4.2.3.3 Impact Resistance

4.2.3.4 Flexibility

4.2.3.5 Fluid Resistance

4.2.3.7 Shrinkage

4.2.3.8 Ease of Application

4.2.3.9 Repairability

5. PREPARATION **FOR** DELIVERY

5.1 DRAWINGS

The drawings required are similar to those required for displacement ships. The only exception is the addition of foil system drawings in the Booklet of General Drawings. This is required due to the great importance of this system to the performance of the ship.

5.2 REPORTING

5.2.1 WEIGHT REPORTING

The Ship Work Breakdown Structure covers all of the systems required in a hydrofoil ship.

It is important that the strut/foil system (SWBS 567) be emphasized. This one system can account for up to 20% of a ship's full load weight. Thus, it is very significant.

As discussed elsewhere, a hydrofoil ship's weight and center of gravity must be strictly controlled. The "Hydrofoil Weight History Report" is designed to aid in this by showing when trouble is starting. It is also an aid after delivery.

5.2.2 SHIP CHARACTERISTICS DATA

The General Characteristics Data Sheets and Detail Characteristics Data Sheets follow the format used in the Hydrofoil Design Data Log (HDDL).

The HDDL contains data on many historical hydrofoils and is designed to aid in the design of new ships. It is available to members of the hydrofoil design community. It is organized by SWBS number and contains a significant amount of data in each group.

5.2.2.1 General Characteristics Data Sheets

5.2.2.2 Detail Characteristics Data Sheets