

**SURFACE EFFECT SHIP (SES)
DEVELOPMENTS WORLDWIDE**

BY

David R. Lavis¹ and Kenneth B. Spaulding, Jr.²

¹ Band, Lavis & Associates, inc., President

² M. Rosenblatt & Son, Inc., Project Manager

SURFACE EFFECT SHIP (SES) DEVELOPMENTS WORLDWIDE

David R. Lavis¹ and Kenneth B. Spaulding, Jr.²

ABSTRACT

It has been more than 30 years since the introduction of the SES. There are several hundred operating SES in the world today. Most are relatively small (less than 200 tons) and have operating speeds of 25 to 40 knots. The potential for larger, faster, S&S has long been recognized. Today, with the emergence of six independent European initiatives for the development of 40 to 50-knot, 500 to 2000-ton, SES car ferries, we are on the threshold of a new generation of SES (Figure 1) • which will be introduced solely because they are perceived, by hard-headed investors, as competitive commercial ventures.

*In this paper the history of SES development is summarized and a world-wide census of SES craft presented. Current fast-ferry and **military** initiatives are discussed. The SES concept is defined and characterized including a discussion of SES technologies. Predictions are made regarding future SES developments, followed by conclusions and recommendations.*

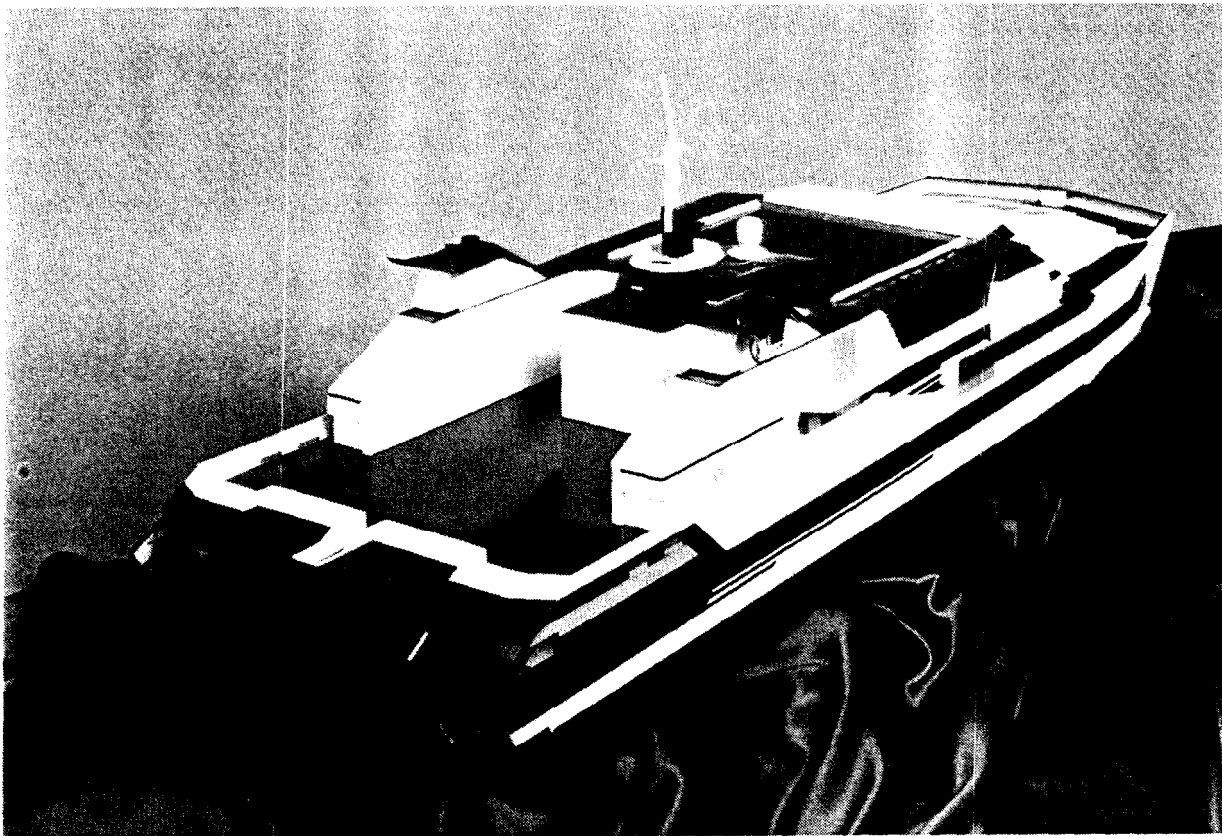

Figure 1. Italian 2000-Ton SEC-774 Car Ferry • The Largest SES (Under Construction)

¹ Band, Lavis & Associates, Inc., President

² M. Rosenblatt & Son, Inc., Project Manager

*Paper presented at the Chesapeake Section of SNAME on 12 March 1991, in Arlington, Virginia.
Currently revised and proposed for publication in the ASNE Journal.*

INTRODUCTION

Commercial shipbuilding in the United States has nearly disappeared. Many yards have closed and the Naval building programs sustaining the survivors are expected to diminish as the defense budget contracts. The good news may be that the labor rates of U.S. yards are now below those of yards in Japan and Northern Europe. In any case, U.S. yards must seek innovative entries into the domestic and foreign marketplace. The SES is an example of an innovation for which the U.S. should be exploiting its early technology lead. The U.S. Navy invested over \$400 million in the 3KSES program alone. The technology lead is now transferring back to Europe where, as this paper will show, the concept is being aggressively pursued for commercial and military applications. The Italian SEC Car Ferry (Figure 1), now in construction, and the French AGNES 200 (Figure 2), now undergoing Navy evaluation, are examples. The design and construction capability for SES is in place in the U.S. The European experience has surely proven the economic feasibility of SES ferries. Perhaps the time has come for our community to realize the potential of SES in the marketplace.

SES HISTORY • CURRENT DEVELOPMENTS

Development of the SES through the 1950's, 1960's and 1970's has been amply documented, notably in References 1 through 7. In this section these early years are summarized, leading to discussions of the current generation of 40 to 50 knot craft and, most importantly, the introduction of several new large fast car-ferry and military initiatives.

Estimates of total SES constructed to date vary with the sources, the highest being "over 450". Table I lists the leading particulars of 297 of the most prominent. This table is based on References 5, 6 and 7 and the authors' personal files, maintained since 1959.

History

The concept of supporting craft on pressurized air dates to the 18th century (Reference 1). Air Cushion Vehicles (ACVs) and Surface-Effect Ships (SES), however, as we know them today, clearly evolved from the pioneering work of Sir Christopher Cockerell, in the UK, starting in 1953. Cockerell's initial focus



Figure 2. The Latest Military SES, The French Navy's AGNES 200 (Commissioned in February 1991)

Table 1

Leading Particulars of Prominent SES

Name	Builder	Country	Launch Year	Number Built	Hull Material	Length Overall (ft)	Beam Overall (ft)	Maximum Speed (kts)	Role
D1	Denny	UK	1961	1	Wood	66	12	17.6	Experimental
D2	Denny	UK	1962	4	GRP	81.5	19	27 to 34	Ferry
XR-1	NAEF	US	1963	1	Wood, Al Alloy	49	13.5	40	Experimental
ZARYA (OPYTNYE-1)	Moscow Shp	USSR	1963	Several	Al Alloy	72.3	12.9	20	Experimental
XR-1 B	USN	us	1965	1	Wood, Al Alloy, GRP	49	19	35	Experimental
XR-3	USN	us	1967	1	Al Alloy	24	12	25	Experimental
HM-216	Hovermarine	UK	1968	30+	GRP	51	20	35	Ferry
GORKOVCHANIN	KSSG	USSR	1969	1	Al Alloy	73	13.2	19	Ferry
100B	Bell	us	1972	1	Al Alloy	77.7	35	94	Experimental
100A	Aerojet	us	1972	1	Al Alloy	91.9	41.9	76	Experimental
ZARNITSA	Sormovo	USSR	1972	100+	Al Alloy	73	13.3	33	Ferry
XR-5	USN	us	1973	1	Al Alloy	46.75	8.25	25	Experimental
XR-1D	Rohr	us	1974	1	Wood, Al Alloy, GRP	50	19	43	Experimental
ORION-01	Sosnovska	USSR	1974	Large	Al Alloy	64.6	21.3	32	Ferry
RASSVET	Sosnovska	USSR	1974	30	Al Alloy	87	23.3	36	Ferry
HM.216	Hovermarine	UK	1976	50+	GRP	60	20	35	Ferry
BH-110	Sell Halter	us	1976	6	Al Alloy	110	39	30	Crew Boat
HM-2 Mk4	Hovermarine	UK	1976	5	GRP*	60	20	35	Ferry and Crew Boat
TURT-II	KTMI	Korea	1976	1	Unknown	27	Unknown	Unknown	Experimental
RODOLF	Bell	US	1979	1	Al Alloy	48	24	33	Survey
PLAMYA	COB	USSR	1980	1	Al Alloy	65.6	21.3	27	Fire Boat
HM 221	Hovermarine	UK	1981	6	GRP	70	20	30	Fire Boat
WR-901	Chaohu	China	1981	4	GRP	63.3	13	21	Ferry
MOLENES	French Navy	France	1981	1	Wood, Al Alloy	39.7	11.3	16	Experimental
HM-527	Hovermarine	UK	1982	5	GAP	69.3	335	40	Ferry
SES-200	Bell, Halter	us	1982	1	Al Alloy	160	39	32	Experimental
TYPE 7203	DAGU	China	1982	1	Unknown	73	22.6	30	Ferry
KTMI-8M	KTMI	Korea	1982	1	Al Alloy	39.4	15.1	30	Ferry
LUCH	Astrakhan	USSR	1983	2	Al Alloy	75	12.6	24	Ferry
HALTER YACHT	Halter	us	1984	1	Al Alloy	70	20	36+	Pleasure
MARIC-717-2 and -3	DFS	China	1984	Unknown	Al Alloy, GRP	70	16.2	24	Ferry
MARIC-719	ws	China	1984	1	Steel, GRP	116	25	30	Ferry
CIRR-105P	Brodrene AA	Norway	1984	1	GRP	106	36	46	Ferry
KTMI-18M	KTMI	Korea	1985	5	Al Alloy	59.4	30	40	Ferry
KTMI 26M	KTMI	Korea	1986	3	Al Alloy	84	33.5	35	Ferry
CIRR-115P	Brodrene AA	Norway	199%	1	GRP	106	36	47	Ferry
CIRR-120P	Brodrene AA	Norway	1987	11	GRP	116	37.7	so	Ferry
JET RIDER	KkrV	Sweden	1987	2	GRP	110	34	48	Ferry
DERGACH'	KBS	USSR	1987	1	Unknown	211.6	55.8	Unknown	Patrol*
BES 16	Bazan	Spain	19%	1	Al Alloy	55	17.7	35	Experimental
MARIC-719-2	Hu	China	19%	1	steel	131	27	28	Ferry
HARPOON	Brodrene AA	Norway	19%	1	GRP	59	23.6	52	Experimental
KTMI-17M	KTMI	Korea	1988	1	Al Alloy	57	16.5	30	Ferry
AIR-RIDE 109	Avondale	US	1969	1	Al Alloy	109	34	30	Ferry
WESTAMARIN 4000	Westamarin	Norway	1989	2	Al Alloy	131	41	52	Ferry
CORSAIR	Blohm & Voss	Germany	1989	1	GRP	118	42.7	52	Patrol/Ferry
AGNES 200	CMN	France	1990	1	Al Alloy	167.3	42.6	44	ASW
SEASWIFT 23	Floyd Scheide	Holland	1990	1	GRP	80	26	37	Ferry
SES-200A	Bell	US	1990	1	Al Alloy	160	42.6	43	Experimental
MTG + MOSES	Lurssen	Germany	1990	1	GRP, Wood	33	8.5	25+	Experimental
TESTRIGG (SMYGE)	KkrV	Sweden	1991	1	GRP	100	37.4	50	Experimental

*Largest SES built to date (1991) at 650 tons, see Figure 26.

was on amphibious applications while others, in the late 1950's, including Denny Hovercraft Ltd (with help from Cockerell) and Allen Ford at the Naval Air Experimental Facility (NAEF) in the U.S., pioneered the development of non-amphibious applications and what has now come to be known as the Surface Effect Ship.

United Kingdom

The first practical SES was the experimental high length-to-beam ratio Denny D-1 which was launched

on 13 May 1961. This craft (Figure 3) was developed, under license to, and with partial funding from, Cockerell's government-sponsored* Hovercraft Development Ltd (HDL), and achieved a maximum speed of 17.6 knots. This was followed, in 1962, by the first GRP SES, the Denny D-2 (Figure 4). four of which were built as commercial ferries capable of carrying 70 passengers and of achieving a maximum speed of 27 knots. Subsequently, they were modified to allow speeds of 34 knots.

*UK National Research Development Corp. (NRDC).

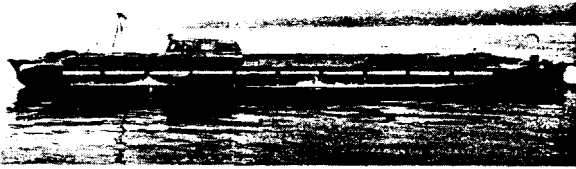

Figure 3. Denny D-I Test Craft (UK)

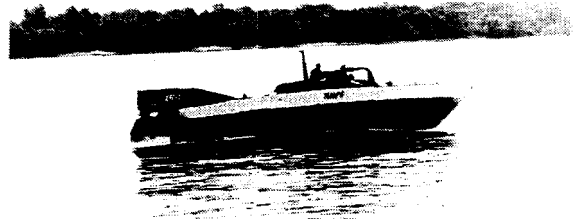

Figure 5. NAEF XR-1 Test Craft (U.S.)

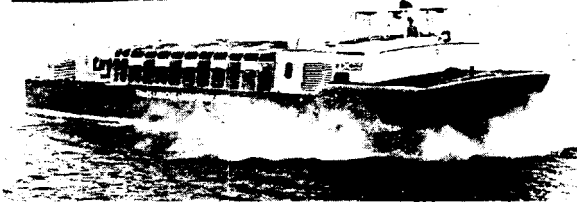

Figure 4. Denny D-2 Passenger Ferry (UK)

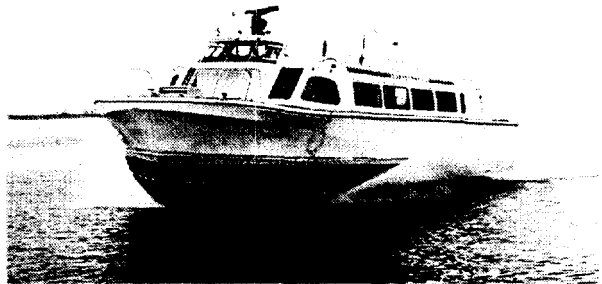

Figure 6. HM-216 Passenger Ferry (UK)

In late 1963, HDL (formed in 1958) launched the HD.I, a research SES which was later converted to a fully amphibious ACV. In 1965 SES development was picked up by Hovermarine, Ltd who launched, in 1968, the first of a very successful series of diesel-GRP SES including the HM-216, 218, 221 and 527 (Figures 6 to 9). These craft primarily operated as passenger ferries but included a number of utility craft such as fireboats (Reference 8). By 1991, a total of 113 HM craft had been delivered. Many of these craft, operating at speeds of 35 to 40 knots, are still in service, with the majority in East Asia.

United States

At NAEF in the U.S., the objective was to achieve higher speeds for military applications. In 1963 the U.S. Navy's low length-to-beam ratio experimental XR-1 (Figure 5) was launched (Reference 9). This craft saw four major configuration changes in its 20-year life, including waterjets in 1970, to achieve speeds of over 40 knots before it was retired as the XR-1 E in 1983 (Figure 11 shows the XR-1 D).

Continuing the pursuit of high speed, in 1965 the U.S. Navy and the Maritime Administration created the Joint Surface Effect Ship Project Office (JSEPO) to develop large SES for both military and commercial applications. MARAD's support was subsequently

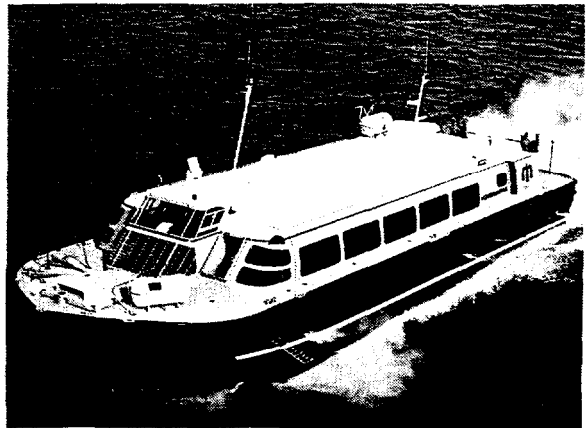

Figure 7. HM 218 Passenger Ferry (UK)

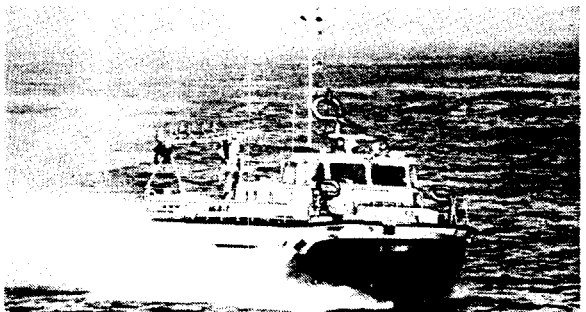

Figure 8. HM 221 Multi-Role Craft (UK)



Figure 9. HM 527 Passenger Ferry (UK)

withdrawn and development proceeded on military missions only. JSESPO became SESPO and later NAVSEA PMS 304.

To provide further understanding of SES seakeeping and stability, another experimental craft, the XR-3 (Figure 10), was built and launched in 1967 as planning evolved for a 500-ton, and subsequently a 2000-ton, SES capable of ASW operations at 80 knots.

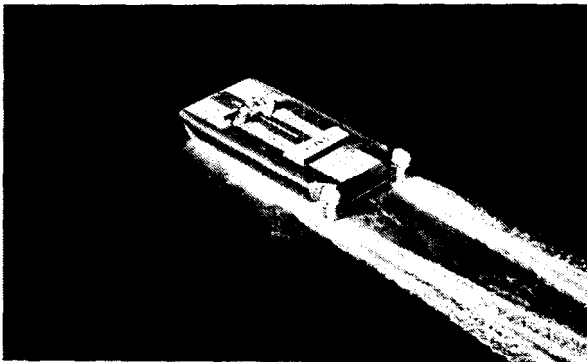

Figure 10. U.S. Navy's XR-3 Test Craft

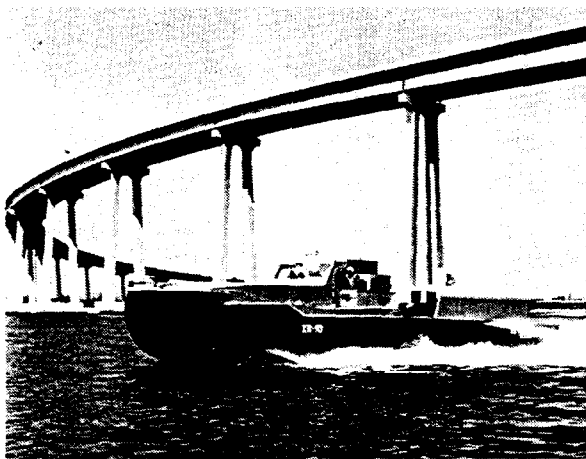

Figure 11. U.S. Navy's XR-1 D Test Craft

In 1972, two 100-ton test craft, the Aerojet SES-100A (Figure 12) and Bell SES-100B (Figure 13), were launched. These craft achieved 76 knots (100A) and 94 knots (100B). From the experience with these craft, and extensive testing, analysis and component development, the design of a 2000-ton ASW frigate was developed. As the ship reached the contract design stage the requirements had changed and the ship had grown to 3000 tons (Figure 14). The 3KSES program was discontinued in 1979. U.S. Navy investment in this program, from its inception in 1967, totaled over \$400 million.

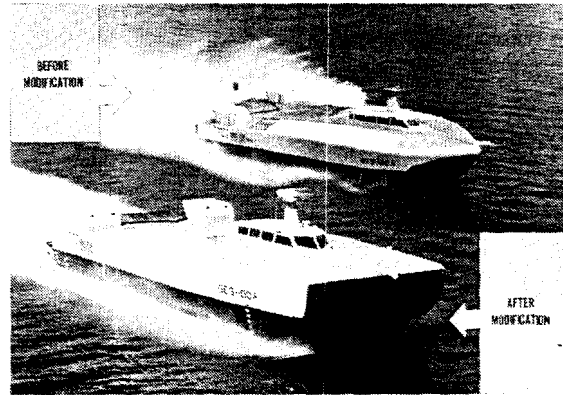

Figure 12. U.S. Navy's SES-100A Test Craft

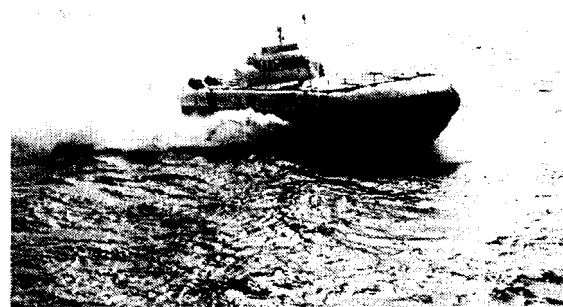

Figure 13. U.S. Navy's SES-1008 Test Craft

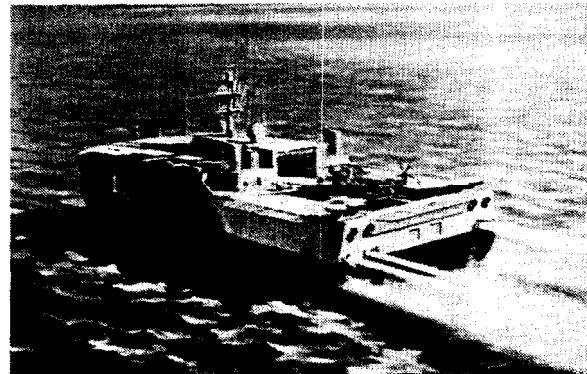

Figure 14. U.S. Navy's 3KSES (Artist's Drawing)

There is still controversy surrounding the demise of the 3KSES program. Clearly cost, risk and a continuing inability to credibly assess the utility of speed were factors (Reference 10). In any case, the military potential of SES was still recognized. As illustrated later in this, paper, the higher length-to-beam ratio SES offered significant speed benefits with reduced development risks and operating costs. Accordingly, sights were lowered from 80 - 100 knots to 40 - 50 knots. The U.S. Navy's high length-to-beam XR-5 test craft (Figure 15) had been launched in 1973 to explore this approach.

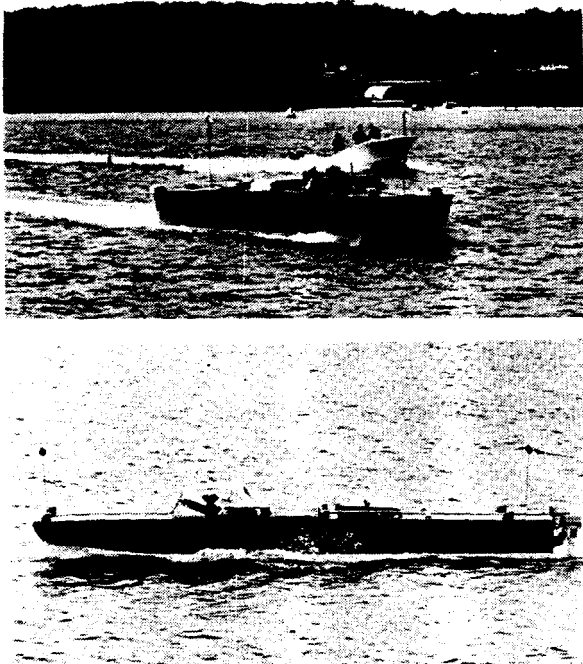

Figure 15. U.S. Navy's XR-5 Test Craft (Two Views)

In 1978 Bell-Halter (currently Textron Marine Systems) designed and built, on speculation, the first commercial SES in the U.S. (Figure 16, References 11 and 12) Six of these craft were built. Three were acquired by the U.S. Coast Guard (Figure 17), one was purchased by the U.S. Navy (modified to become the SES 200) and two are operating as crew boats. Both were shipped to Egypt in 1984 - 1985. One returned to New Orleans and the other was shipped to Brazil in 1988. A scaled down version of the Bell design, the 48-ft Rodolf (Figure 18), was delivered to the U.S. Army Corps of Engineers in 1979. This hydrographic-survey craft is operating out of Portland, OR. At this point the Bell 11 Os, the Rodolf and the SES 200 are completely successful applications of the SES concept, both military and commercial, by a U.S. company.

The U.S. Coast Guard Surface Effect Ship Division in Key West, Florida was established in November 1982 with delivery of the three BH-110 SES which were designated WSES 2, 3 and 4. initially a series of engineering and maintenance problems compromised the effectiveness of the squadron but by 1986 these craft had emerged as the most efficient workhorses in the cutter inventory (Reference 13). Since 1987 the WSEs have averaged well over 3100 underway hours per year with the lowest ratio of maintenance to underway hours of any USCG cutter class. The most economic operating speed is the maximum-continuous speed of 30+ knots. In their drug interdiction role the WSEs operate in a sprint-and-drift mode. These craft are noted for their platform stability, maneuverability, seakeeping and usable deck space as well as their speed. The large deck area has proven particularly effective for migrant interdictions.

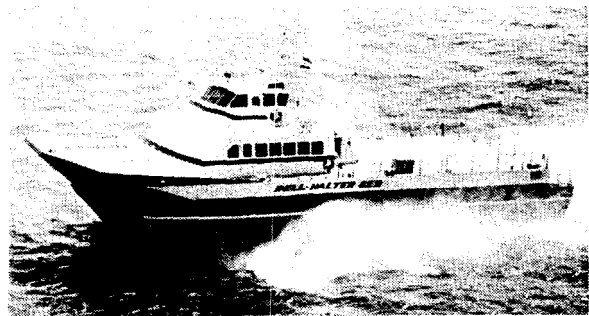

Figure 16. Bell (U.S.) BH-110 Crew Boat

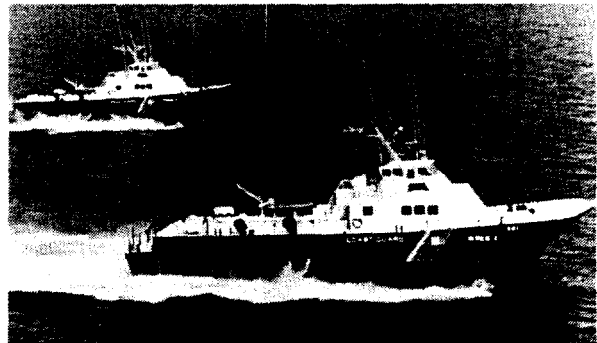

Figure 17. Bell-Halter, USCG Cutters



Figure 18. Bell Rodolf, U.S. Army, Hydrographic Vessel

The DTRC SES-200 was launched in 1978 as a Bell Halter 110. The craft was purchased by the Navy and lengthened by 50 ft (Figure 19). A ride-control system was also added. A six nation NATO test deployment was completed in 1986, followed by various SES technology and weapon-systems evaluations (including the Vulcan Gun and Hellfire missile systems). The SES 200 has just completed a major upgrade under a Foreign Comparative Test Program (FCT) which included hull modifications and installation of MTU diesels, KaMeWa waterjets and ZE gearboxes (Figure 20). The new propulsion system is similar to that in the AGNES 200 prototype and the German SES-700 design. As the modified SES-200 enters its test and evaluation period it has already demonstrated speeds of over 40 knots.

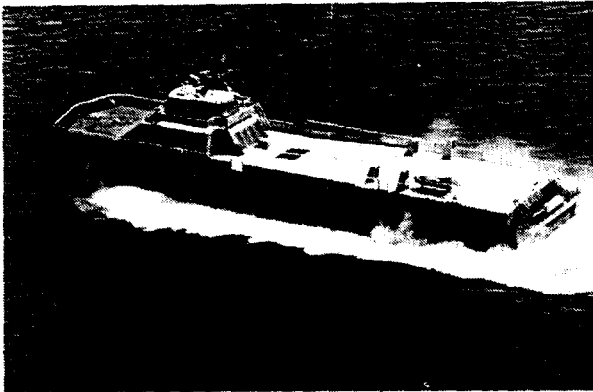

Figure 19. U.S. Navy's SES-200

In the early 1980's a contract was awarded to Textron Marine Systems for the construction of a number of US. Navy GRP SES Mine Countermeasures craft (MSH). The contract was terminated before construction of the first craft.

At this time, the Navy also developed the concept of an SES Special Warfare Craft, Medium (SWCM). A contract was awarded to RMI which was also terminated before completion of the first craft.

An SES motor yacht was constructed by Halter Marine in 1983. It is currently being upgraded by the Trinity Marine Group (Figure 21).

Two 109-ft aluminum hybrid SES (wet-deck forms stern seal) were constructed by Avondale Shipyard Yacht Division to a design by Air Ride Craft, Inc. The first of these air-ride ferries (Figure 22) initiated operations from lower Manhattan to Kennedy airport in the Spring of 1990.

A twin-cushion (SECAT) SES manned model was built and tested by the U.S. Navy in 1985. An artist drawing of the full-scale concept is shown in Figure 23 (Reference 37).

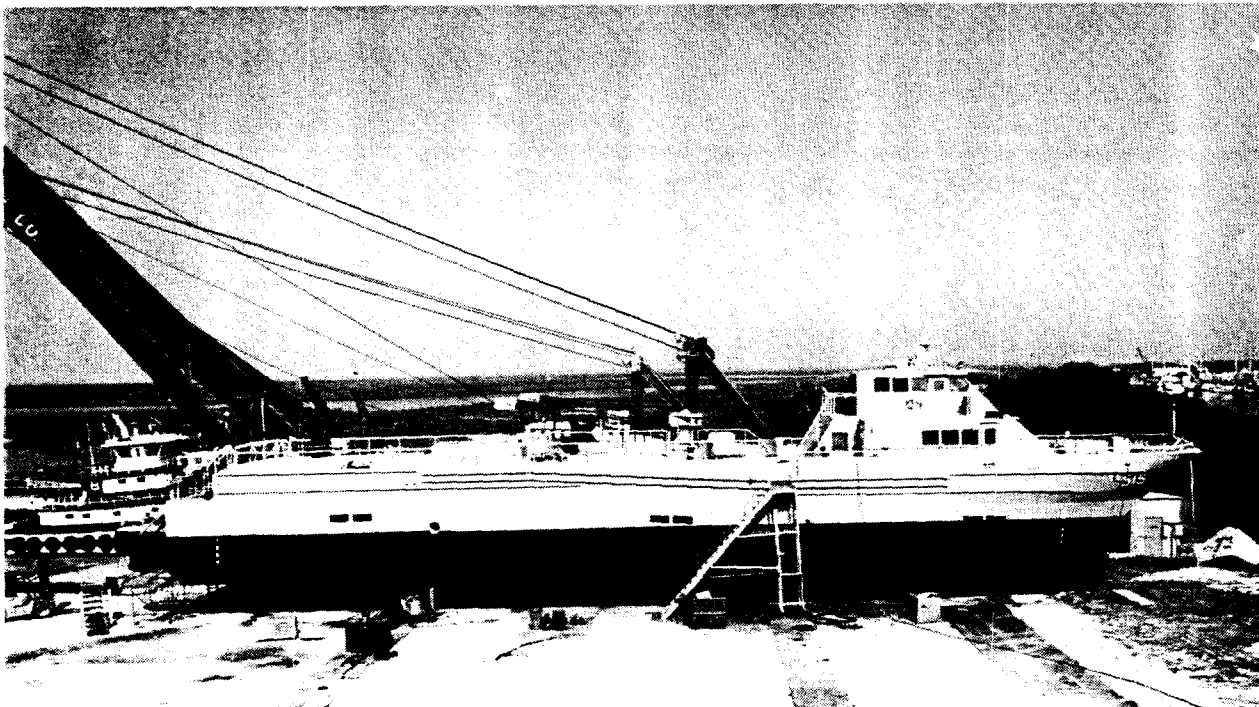

Figure 20. U.S. Navy 250-Ton SES 200 After Waterjet Retrofit

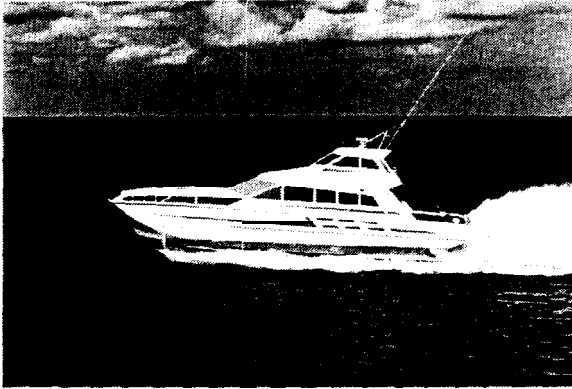

Figure 21. Halter 70-ft SES Sport Fisherman (U.S.)

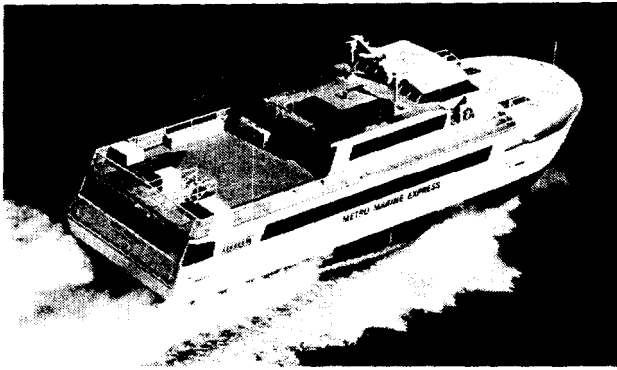

Figure 22. Avondale (U.S.), Metro Marine Express



Figure 23. U.S. Navy's Surface Effect Catamaran, SECAT (Artist's Drawing)

During the 1970's and 1980's a large number of feasibility level SES design studies were conducted

by the Navy. These ranged from a 300-ton NATO Patrol Craft to large Air Capable Cruisers and Sealift ships to over 20,000 tons (References 14 and 15).

San Diego Shipbuilding has, for several years, been licensed by the Norwegian firm of Cirrus for the construction of several 120P passenger ferries for operation in Hawaii. At this time, the future of this venture is uncertain.

USSR

Commercial SES development in the USSR has concentrated on relatively low-speed, shallow-draft passenger ferries for operation in the vast Soviet network of shallow rivers and tributaries.

Craft built and operated to date have been relatively small (50 to 80 seats) and have operated predominantly on short routes in protected waters.

The Zarnitsa (Figure 24) was the first Soviet SES ferry put into production and evolved from the Gorkovchanin prototype which was first tested in 1968. The Zarnitsa is a 72-ft long, 50-seat, waterjet-propelled craft capable of operation in water depths of less than 2-ft and at speeds of over 30 knots. More than 100 of these craft are employed on rivers throughout the USSR.

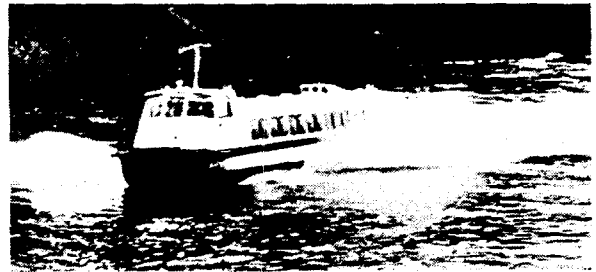

Figure 24. Soviet Zarnitsa ("Lightning")

This was followed by the series production of several hundred SES, principally river ferries, of several classes, including Orion-01 (1975), Chayka (1976), Rassvet (1976, Figure 25), Plamyá (1980, Figure 26) and Luch (1983).

The Orion is an 80-passenger ferry capable of slightly higher speeds than the Zarnitsa. Like the Zarnitsa, the Orion is intended for service along shallow rivers, tributaries and reservoirs and is waterjet propelled. At

a displacement of 35 tons and a length of 85 ft, the Orion can operate in choppier water conditions than can the Zarnitsa.

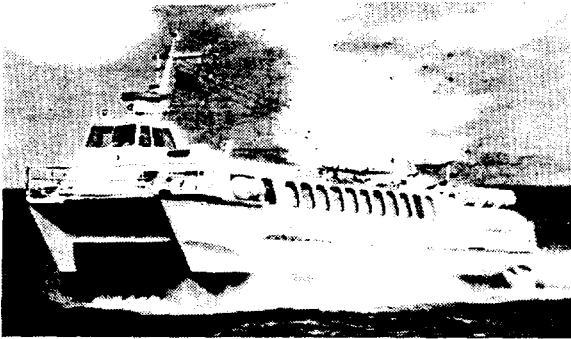

Figure 25. Soviet Rassvet

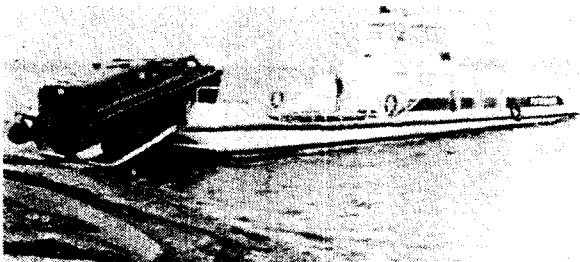

Figure 26. Soviet Plamya

The Rassvet (Figure 25) is the largest Soviet commercial SES built to date. The 47-ton Rassvet is designed to operate on offshore routes in the Baltic, Caspian and Black Seas, as well as on large lakes and **reservoirs** in conditions up to sea-state 3.

The Plamya (Figure 26) is a variant of the Orion and it is designed to transport and land vehicles. Versions are also used as river fire boats.

The **Luch-1** is the newest Soviet SES ferry and was designed to replace the then **12-year** old Zarnitsa class. Although approximately the same size as the Zarnitsa, the Luch-1 has an increased speed capability and greater payload capacity (up to 66 passengers). Like all of the Soviet SES ferries, it is designed to run bow-on to any flat sloping bank and to embark and disembark passengers via an articulated gangway.

One Soviet ferry, the Zarya (Figure 27) is often discussed along with SES. However, the Zarya is not

an SES, merely a very shallow draft planing trimaran-type craft. Claims of a significant ram-& cushion being generated at the 24-knot service speed of the craft must be viewed with extreme skepticism. Over 150 of these **60-passenger** shallow-draft planing craft are in operation.

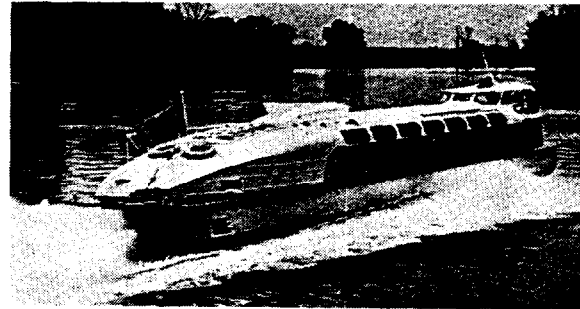

Figure 27. Soviet Zarya Catamaran (Two Views)

The Soviets are reportedly developing faster, larger SES passenger/car ferries (having speeds of 36 knots and displacements up to 100 tons) for use along shallow waterways unsuitable for hydrofoils. Recent reports also suggest that the Soviets are developing large (**2000- to 4000-ton**) SES freighters. However, construction of these larger craft has not been confirmed.

For military applications, the Soviets have concentrated on amphibious **ACVs**. However, during the **1980's**, the Kamysh-Burun Shipyard (KBS) in **Kerch**, developed what is currently the world's largest SES, the **650-ton** Dergach Patrol Craft, which was commissioned in early 1990 (Reference 16). This SES, shown in Figure 26, is discussed in more depth later in the paper.



Figure 28. Soviet 650-Ton Dergach Combatant SES (Canadian Forces Photo courtesy Guide to the Soviet Navy)

People's Republic of China (PRC)

The Marine Design and Research Institute of China (MARIC) began investigation of the SES concept in the early 1960's. By 1967 MARIC was testing a 2-ton SES test craft, designated 71 I-3. In 1975 the ChaoHu Shipyard in Au-Hui Province was testing an experimental 5-ton MARIC design. This yard produced, in 1980, the 70-seat Jing-Sah SES ferry, followed in 1981 by the waterjet-propelled SES ferry, WR-901, of which four were built, and, in 1983, the 42-seat Tai Hu.

The Dagu Shipyard in Tianjin was next with their Type 713 and 717 (built in the 1970's), the 7203 passenger ferries the prototype of which was launched in 1982 and the JINXIANG 80-seat passenger ferry launched in 1983.

In 1984 the Wuhu Shipyard (WS) produced the MARIC-719, the first SES with a hull constructed of steel (and superstructure of GRP, (Figure 29)). A Mark-II version of this craft, also built of steel, entered passenger service in 1988.

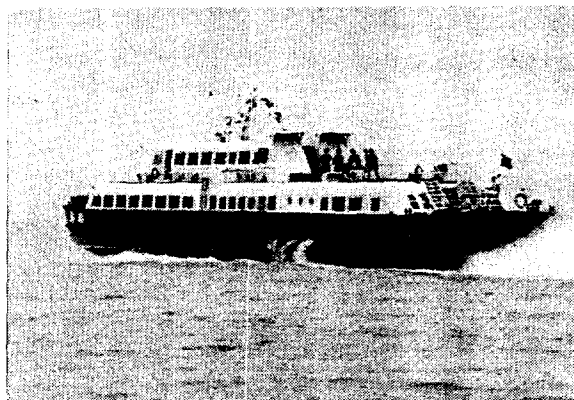

Figure 29. China's MARIC 719-II Steel SES

The Dong Feng Shipyard (DFS) has also built passenger-carrying SES, two of which are waterjet propelled, designated Type 717 (Figure 30). Their latest version, Type 717 III, carries up to 171 passengers. Two of these craft entered service in 1984 and 1988, respectively.



Figure 30. China's MARIC 717-II Waterjet SES

The Huangpu Shipyard in Guangzhou is scheduled to deliver another **MARIC** design in 1991. This craft is designated Type 7211 and will carry up to 171 passengers at 30 knots. According to JANE'S (1985) the Chinese have also built (starting in 1977) a number of waterjet-propelled military river-patrol craft.

South Korea

In 1978 Korea Tacoma Marine Industries (KTMI) launched the 27-ft experimental **Turt-II** SES. By 1988 KTMI had launched five 60-ft SES, one 36-ft SES, one 56-ft SES, two 85-ft SES and one 92-ft SES ferry, the latter developed as a derivative of the 85-ft version. Further details, including photographs, of these craft can be found in References 5 and 6.

France

During the late 1970's serious interest in SES from mainland Europe was beginning to appear and by 1981 the French Navy's Direction Des Constructions Navales (DCN) were testing a small experimental craft called Molenes (Figure 31).

DCN recognized the potential of SES as a helicopter platform and embarked upon an extensive research and development program aimed at a 1250-ton ASW corvette, the Eoles (Reference 21) Their next step beyond the Molenes was the AGNES 200 (Figure 2) which was launched at CMN in Cherbourg during 1990, and is currently undergoing trials with U.S. Navy support,

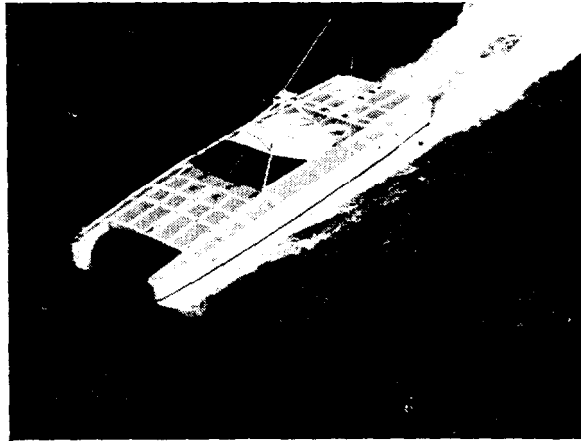

Figure 31. French Navy's Molenes Test Craft

The hull structure and deckhouse of the AGNES 200 are welded aluminum (described in more depth later). Propulsion is MTU diesels with **KaMeWa** waterjets. The deck aft will accommodate a Dauphin helicopter. The prototype has a 90-seat passenger salon but, in a ferry configuration, the AGNES 200 could accommodate 450 passengers. AGNES 200 is classified by Bureau Veritas as an AUT-CC passenger ship.

The design of a 152 passenger fast ferry SES has been developed by the firm of Ingenierie Maritime et Commercialisation (IMC)/Efair. The hull is cored GRP and propulsion options include MAN or Deutz diesels and waterjets or propellers. Details can be found in Reference 5.

Norway

The geography of Norway has supported a proliferation of passenger ferries of many types. Competition is intense and new concepts are aggressively pursued whenever economic advantages are perceived. The building firm of Brodrene **Aa**, with yards at Eikefjord and Hyen, pioneered the application of cored GRP to hull construction and, subsequently, in partnership with the design firm of Cirrus, evolved their catamarans into the first Norwegian "Air Cushion Catamaran," or SES, the **Norcat** (Figure 32). This craft was launched with marine-screw propulsion and was subsequently converted to waterjet propulsion. The Cirrus/Brodrene **Aa** team subsequently produced a second "Norcat" (CIRR 115P, Figure 34), the Ekwata and the experimental, hybrid propeller driven, Harpoon (CIRR 60P) (Figure, 33) followed by series production of eleven CIRR 120P class ferries (Figure 35). The 120Ps, operating in many parts of the world, represent the state-of-the-art in SES passenger

ferries. Of GRP cored construction, they are powered by MWM diesels with **KaMeWa** waterjets providing a service speed in the mid 40s. All of the 120Ps are equipped with ridecontrol systems developed by the U.S. firm of Maritime Dynamics. The most recent delivery, the Nissho for a Japanese customer, was powered by MTU diesels for a service speed of 51 knots.

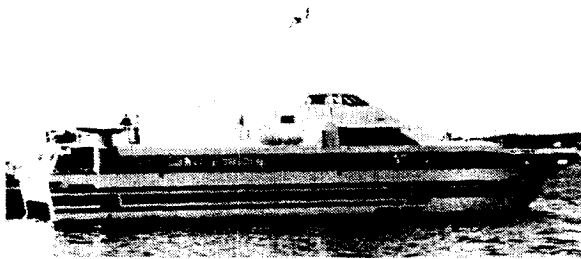

Figure 32. Norway's CIRR 105P Norcat

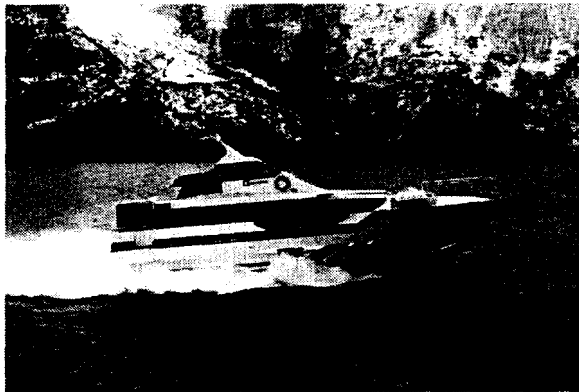

Figure 33. Norway's Harpoon - CIRR 60P

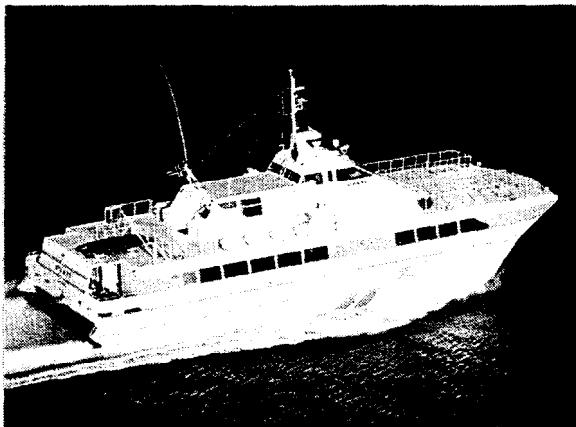

Figure 34. Norway's CIRR 115P

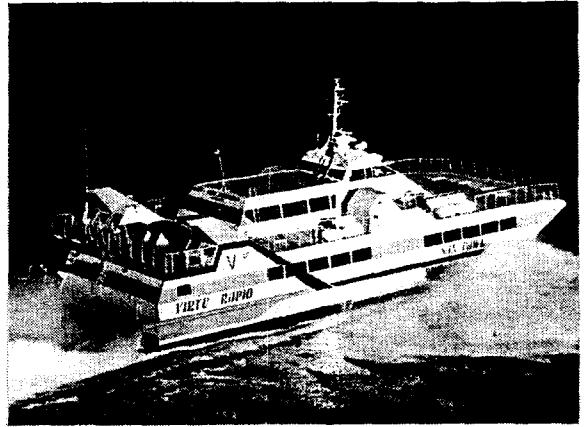

Figure 35. Norway's CIRR 120P

Early in 1990 Cirrus acquired 50% interest in a shipyard in Rosendal and, on 1 June, the partnership with Brodrene Aa was dissolved. Cirrus has developed designs for two large SES car ferries and a 220-ton SES attack craft. They have also participated in the design of the Norwegian SES MCMVs (Figure 36). These activities are described later.

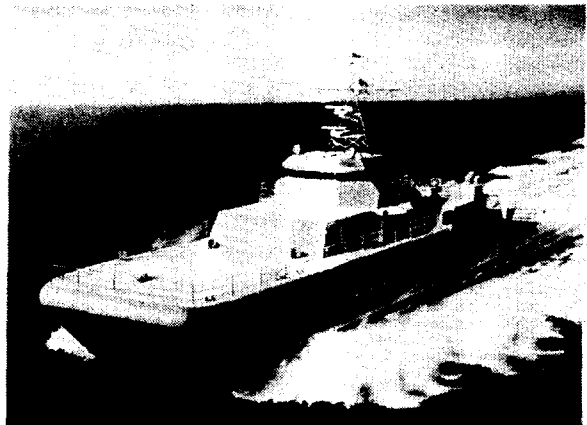

Figure 36. Norwegian Navy's MCMV SES
(Artist's Drawing)

Brodrene Aa has now joined the Ulstein Group and is building two luxury 37-meter SES passenger ferries designated UT904. The first is scheduled for delivery to a customer in Greece in July of this year. The UT904 is also being offered in an offshore supply variant which will carry 100 passengers and 20 tons of deck cargo.

Westamarin, in partnership with Karlskronavarvet (KKrV) in Sweden, has produced two aluminum

SES-4000 class ferries (Figure 38). The two SES Jet-Rider 3400 ferries (Figure 37), designed by KKrV in conjunction with Textron Marine Systems and constructed by KKrV in cored GRP, were fitted out at the Westamarin yard.

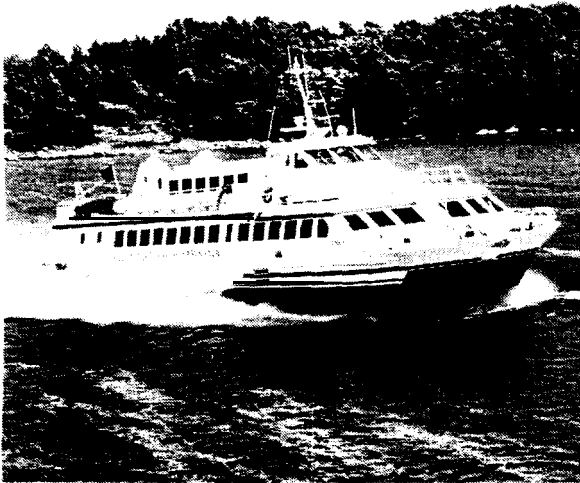

Figure 37. Sweden's, KKrV Jet Rider 3400 Ferry

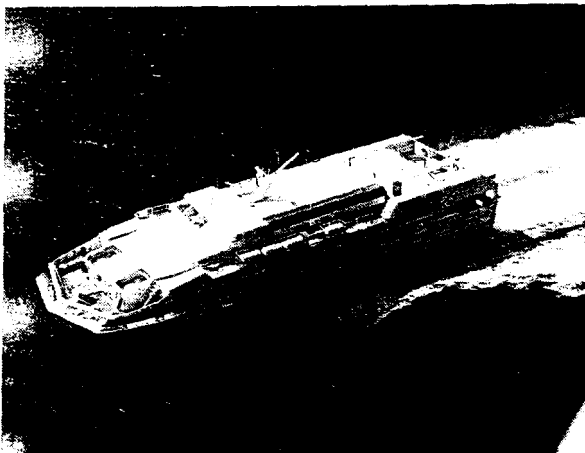

Figure 38. SES-4000 Class Ferry (Norway/Sweden)

Sweden

Karlskronavarvet (KKrV) entered into an agreement with Textron Marine Systems in the U.S., and in 1987 completed construction of the two cored-GRP Jet Riders (Figure 37, Reference 17). In 1989, KKrV supported construction of the two SES-4000 craft by Westamarin Norway (Figure 38).

The Swedish Defence Materiel Administration (FMV) and KKrV have engaged in the development of SES concepts and technology since 1983. Studies and tests were conducted by KKrV in 1985 to 1986 and, in

1987, FMV initiated a comprehensive SES R&D program involving a number of Swedish firms and government agencies. These activities led to a 1989 building contract with KKrV for the stealth test craft "Testrigg SMYGE," Figure 39, (Reference 18), which is discussed in more depth later.

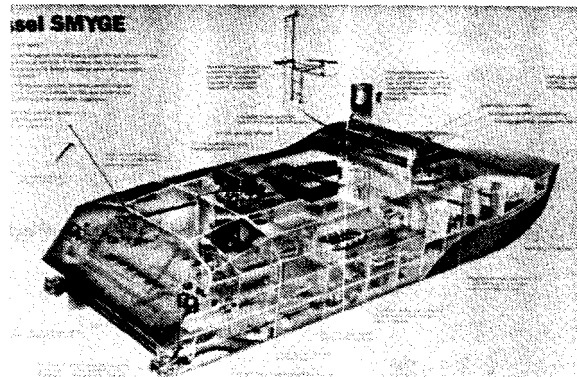

Figure 39. Sweden's KKrV Testrigg "SMYGE" (Artist's Drawing)

Germany

The firm of Blohm und Voss in Hamburg, Germany, began their studies of SES in 1982. These studies culminated in the launching, in 1989, of the 36-meter Corsair (Figure 40). This (50+-knot) demonstrator for both military and commercial applications, embodies several significant technology advances. The hull is cored GRP utilizing a high-strength core material. MTU diesels, suspended in modules from an overhead foundation for shock and vibration isolation, drive Escher-Wyss seven bladed semi-submerged CP propellers with flow control flaps mounted forward of the propellers. The design is based on the Blohm und Voss modular MEKO principles allowing use of various demonstrator modules. The construction and evaluation of the Corsair has been supported financially by equipment, or manpower, from 21 firms. Corsair trials continued through 1990 and into 1991, in cooperation with the German MoD. Trial displacements have ranged from 165 to 195 tons and speeds of 20 knots have been maintained in 3-meter seas. During February of this year, a 57-mm Bofors gun module was installed for firing tests, with the Signal Gemini Fire-Control System.

Based on the Corsair experiment, Blohm und Voss is developing a number of larger military and civilian SES concepts.

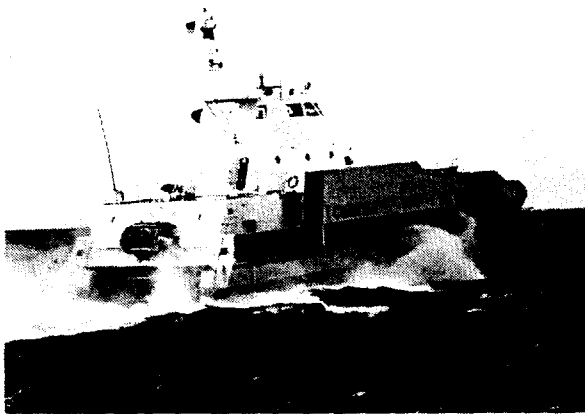

Figure 40. Germany's B+V Corsair

For eight years, the German MoD, supported by MTG in Hamburg, has been developing, in cooperation with the U.S., the design of a 700-ton SES (Reference 19). A 10-meter 1 to 6.3-scale test craft, the Moses, designed by MTG and built by Lurssen Werft in Bremen, is currently being evaluated at the MoD Navy Ship Test Center at Eckernforde, near Kiel (Reference 20).

Spain

The Spanish Ministry of Defense initiated an ACV development program in 1976 which has resulted in the construction, by the firm of Chaconsa, of the 45-ton amphibious assault VCA-36 which has successfully completed an evaluation program and is a candidate for series production. Spain subsequently entered the SES field with the NATO SWG/6 design of an SES Corvette and has now embarked on a patrol-craft program targeted on the 350-ton BES 50 (Figure 41). A 14-ton, 1 B-meter, proof-of-concept craft, the BES 16 (Figure 42) is currently completing sea trials.

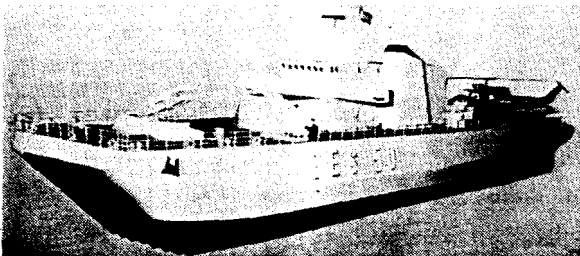

Figure 41. Spanish Navy BES 50 (Artist's Drawing)



Figure 42. Spanish Navy BES 16

Italy

In 1987, an 8-meter test craft, the TSES8, was evaluated in a collaboration of the Italian firms of Stain and Turmomecoania Italiana. Subsequently, a 26-meter, 200-passenger, SES ferry design, the TSES26, was developed and a 26-meter, 400-passenger, SES was proposed as a challenger for the Trans-Atlantic Blue Riband.

The Italian MoD has been active with the NATO SWG/6 Group and has contracted SES studies with Cetena and Fincantieri. The current SEC and Fincantieri initiatives are discussed later.

The Netherlands

Royal Schelde's 24-meter, 132-passenger, aluminum SES ferry, **Seaswift 23** (Figure 43) began builder's trials in August of 1990. Construction of this craft was supported by a \$1 million development loan from the Ministry of Economic Affairs. Thirty-four meter and 60-meter designs have also been developed.

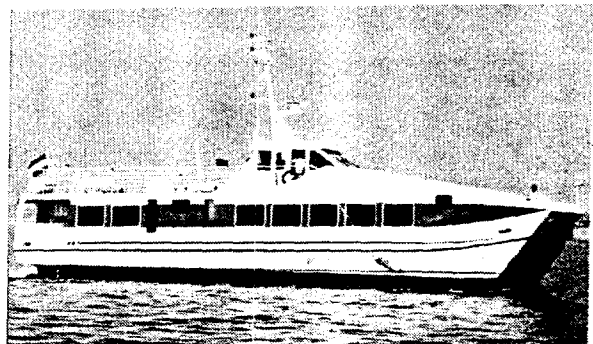

Figure 43. Royal Schelde's Seaswift 23
(Netherlands)

The firm of LeComte has, in construction, an innovative 89-ft SES which utilizes cored GRP hulls with

modular aluminum deck and superstructure. Of particular interest are the bow and stern **seals** which are formed from hinged individual GRP "fingers".

NATO Special Working Group Six (SWG/6) (Advanced Vehicles) (Reference 21)

This NATO working group, which currently includes 11 nations, is chartered to assess the potential of advanced vehicles for the various NATO Naval missions. In 1987 the group completed a four year ASW study. Seven designs, including four SES ASW Corvettes were developed and assessed. Currently the group is evaluating Advanced Naval Vehicles (ANVs) for the NATO Patrol and MCM missions. SES designs have been developed for three patrol missions and an SES option is being explored for the MCM mission. One option for the Patrol-Craft Mission, designed for NAVSEA by Band, Lavis & Associates, Inc., is shown in Figure 44. Of the 11 NATO SWG/6 nations, eight have actively pursued SES studies and/or development programs.

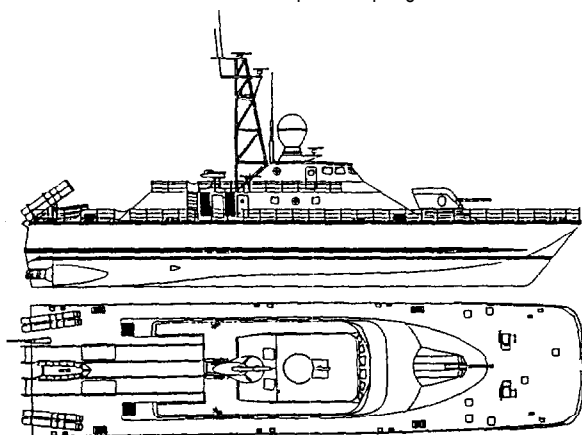

Figure 44. SES Design for NATO Patrol-Craft Missions (U.S.)

The New Wave - Ferries and Military Craft

It appears that we are on the threshold of a new generation of large, high-speed, passenger-car and military SES. The initiatives **described** in this section represent a major technological step in scale, if not in basic technologies. The potential benefits, both commercial and military, are significant. Table 2, summarizes the leading particulars of the car-ferry designs.

Germany

Studies for the SES-700 began in 1984 (Reference 19). The principal design analysis was accomplished by MTG Marinetechnik GmbH in Hamburg under direction of the Ministry of Defense. Under FMS agreements, model testing was conducted at DTRC and NAVSEA design support was provided. By the Spring of 1987 a Contract Design was complete. Model testing continued into 1989, focused on reducing motions in **3-meter** seas. Acquisition funding for the SES-700 would not be available before 1995.

The SES-700 would enter the FRG test fleet as a high-speed test craft for evaluation of combat systems and SES technology. It could **also** be considered as a proof-of-concept for an SES Corvette or Frigate. Requirements specified a minimum speed of 50 knots and unrestricted Baltic operation up to a significant wave **height** of 3 meters.

The resulting Contract Design (Figure 45) represented a steel hull SES with two Allison 571KF turbines driving **KaMeWa** waterjets.

Table 2

Leading Particulars of Passenger-Car Ferry Designs

Builder/Designer	Country	Hull Material	Length Overall (ft)	Beam Overall (ft)	Passenger Seats No.	Cars No.	Maximum Speed (kts)
SEC	Italy	Steel	302	75	750	180	50
Cirrus	Norway	GRP	198	55	364	56	47
Fincantieri	Italy	Al Alloy	217	60	450	80	46
Hovermarine	U K	Al Alloy	262	82	750	95	55+
Royal Schelde	Netherlands	Al Alloy	194	54	436	62	46
Textron (Bell)	U.S.	Al Alloy	162	48	289	27	43
MTG	Germany	Al Alloy	226	53	380	56	50

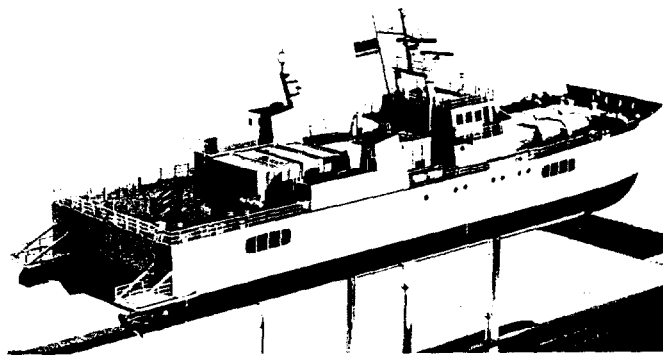

Figure 45. German, SES-700 (Display Model)

A 10-meter manned model of the SES-700 (Figure 46), was designed by MTG and completed by Fr. Lurssen **Werft** in Bremen in August of 1990 (Reference 20). This craft will be tested extensively in 1991 and 1992 by the German **MoD** Navy Ship Test Center at Eckernforde.

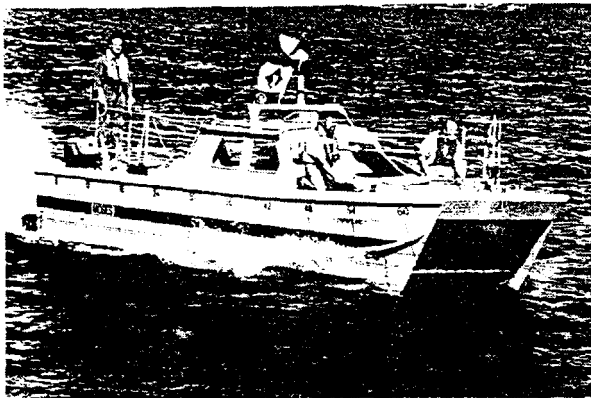

Figure 46. German **6.3-Scale** Manned Model (Moses) of SES-700

MTG (Reference 57) has also designed a 600-ton car-ferry variant of the SES-700, designated SES 600 (Figure 47). The SES 600, of aluminum construction, will **carry** 380 passengers and 56 cars. The propulsion system consists of four **LM500s** and two **KaMeWa** waterjets.

Based on experience with the Corsair (Figure 40), Blohm und Voss has developed the design of a cored GRP, 300-passenger, SES ferry. A **500-passenger** ferry has also been considered. A 43-meter military version with a full-load displacement of **185-tons** and a speed over 40 knots has been proposed. Application of the Blohm und Voss modular MEKO system

will facilitate application of one basic platform to MCM, police, surveillance, fast **attack** and ASW missions, all of which could include helicopter capability.

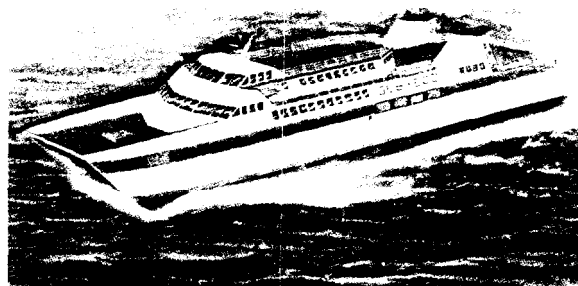

Figure 47. SES 600 MTG Design Study of a Passenger/Car Ferry

France

The French Navy has a firmly established SES development program leading from the AGNES 200 (Figure 2) to a **1250-ton** ASW Corvette (EOLES). A variant of the EOLES was developed by France for the NATO SWG/6 ASW studies reported in Reference 21.

Italy

Societa Escercizio Cantieri SpA (SEC), the largest private shipbuilder in Italy, initiated studies in 1986 to identify the best concept for transporting 300 passengers and 70 cars at speeds over 40 knots. These studies considered SWATH, hydrofoils, SES, catamarans and **wave-piercing** catamarans. SES was selected and consultants from Sweden, the U.S. and the UK were engaged.. Studies included extensive model testing. Navy International of September 1990 reported that two vessels (with an option for a third) were contracted with Sea Searchers Sud for the Italy-to-Sardinia and Corsica routes. Construction of the first ferry, designated SEC-774 is underway.

The hull of the **2000-ton** SEC-774 (Figures 1 and 48) is constructed of high tensile steel. Trade-off studies with cored GRP and aluminum were conducted. The superstructure is aluminum. Payload is 750 passengers and 180 cars. With a length of 302 **ft** she is **36-ft** longer than the U.S. Navy's 3KSES design. Maximum speed, **full-load**, is 50 knots (32 knots in sea-state 6). Model tests at 35 knots in sea-state 6

reported accelerations of less than 0.15 g, rms. Propulsion is two LM-2500 gas turbines with waterjets. A ride-control system is provided. Full compliance with SOLAS rules is specified as IMO 373 is limited to 450 passengers (Reference 22).

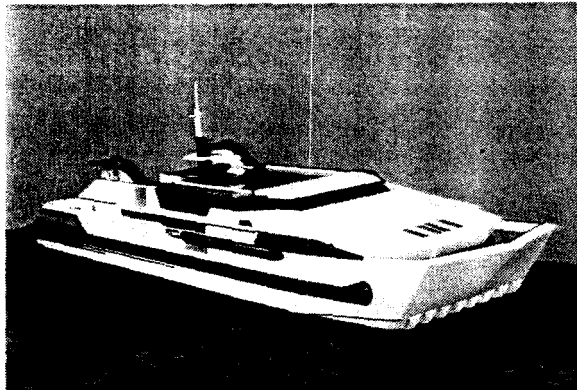

Figure 48. Italian SEC-774 Car Ferry (Display Model)

A "Fast Frigate" variant of the SEC-774 with speeds to 50 knots (Figure 49) has been proposed. In addition 450-passengers/208-cars/59-knots and 750-passengers/208-cars/45-knot variants have been developed.

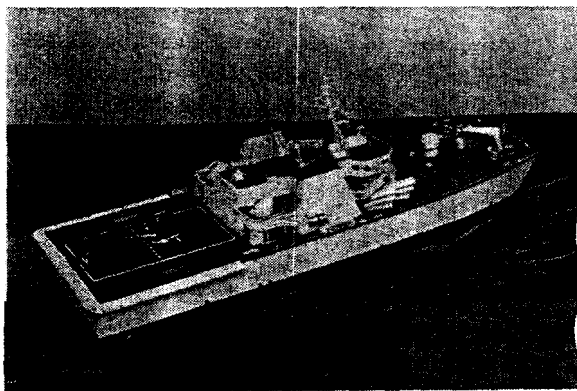

Figure 49. Italian Fast Frigate Variant of SEC-774 Car Ferry (Display Model)

Fincantieri has completed the detail design phase of their two standard platforms; the SES 250 and SES 500. These designs were developed in the Naval Shipbuilding Division in Genoa where the Sparviero hydrofoils were designed and constructed. Both designs were extensively model tested and structural finite element analysis was performed. Cost analysis

for various Mediterranean ferry routes has also been completed. Both ferries would be built in accordance with Registro Italiano, Navale's highest light craft requirements; 100 - A(UL) - 1.1 - NAV.S. Both craft will also meet applicable Det Norske Veritas requirements (Reference 23). Both SES 250 and SES 500 are welded aluminum and have ride-control systems and Riva Calzoni waterjets.

The SES 250, with a full-load displacement of 220 tons, carries 450 passengers with a maximum full-load speed of 42 knots. Propulsion units are two MTU diesels. Military versions of the SES 250 include a Strike (Figure 52) and an ASW version with maximum continuous speeds of 50 knots.

The SES 500 (Figures 50 and 51) with a full-load displacement of 520 tons, carries 450 passengers and 80 cars with a full-load speed of 46 knots. Propulsion units are two Allison 571 KF gas turbines.

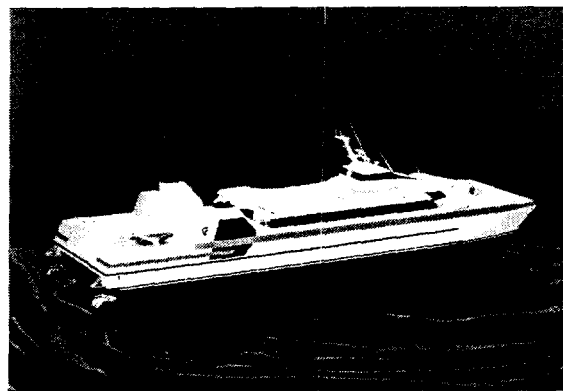

Figure 50. Italian Fincantieri SES-500 Car Ferry (Display Model)

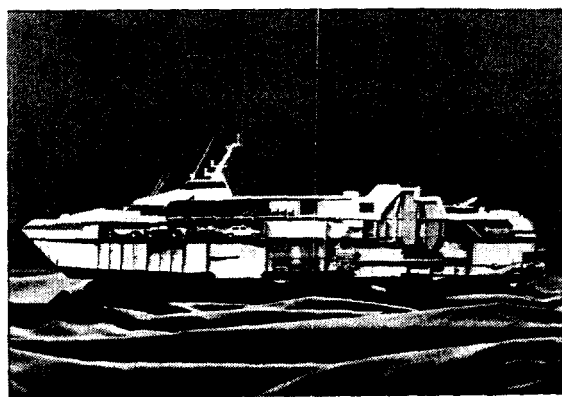

Figure 51. Italian Fincantieri SES-500 (Cut-Away Display Model)

The Italian MoD has developed requirements and a design for an SES patrol craft as part of the current NATO SWG/6 studies.

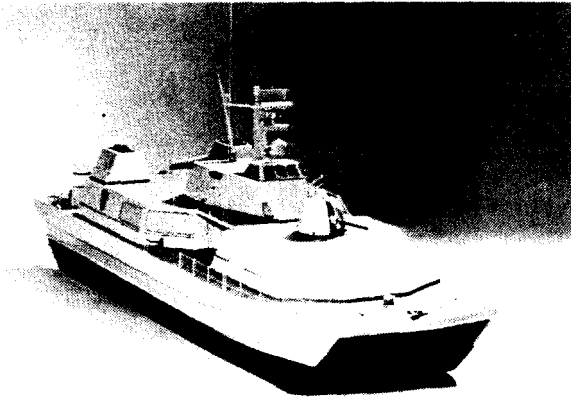

Figure 52. Italian Fincantieri • Strike Version of SES 250 (Display Model)

Japan

A five year project, "Techno-Superliner '93," was initiated in Japan at the beginning of 1989. Funding of the study is understood to be \$11 million, one third provided by the Ministry of Transport and the remainder by seven shipyards and heavy industries. The objective of the study is the definition of a feasible concept, by the end of 1993, for a vessel carrying 1000 tonnes at 50 knots for 500 miles, with acceptable seakeeping capability. The first three years are to be devoted to research and design with the final two years for the development of a demonstration model. Such a high speed carrier would allow transit from Japan to China, Taiwan or Korea in one day. At this point it is understood that SES is very much in the running.

The Netherlands

As noted previously, Royal Schelde is currently evaluating the **Seaswift** 23 (Figure 43), They have developed designs for the **34-meter Seaswift** 34 (Figure 53) and the **60-meter Seaswift** 60.

The **Seaswift** 60 (Figure 54) has undergone some redesign based on results of trials on the **Seaswift** 23. The current version is understood to carry 436 passengers and 62 cars. Diesel and gas turbine options are offered, both with **waterjet** propulsors.

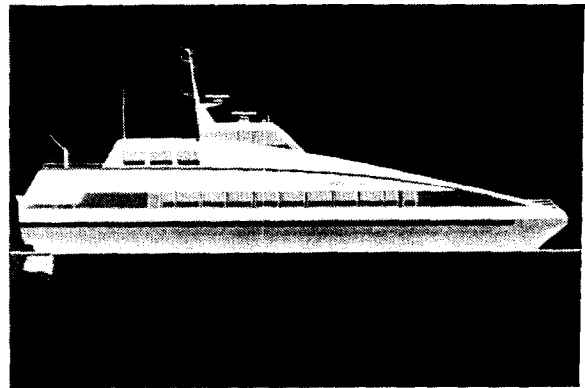

Figure 53. Dutch, **Royal Schelde**, Seaswift- Passenger-Ferry (Artist's Drawing)

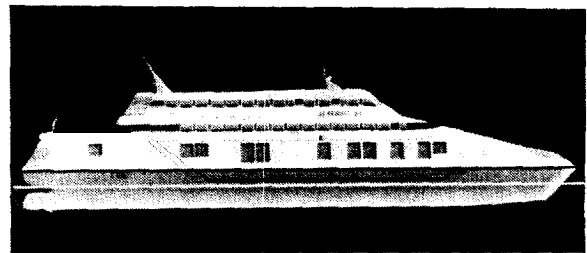

Figure 54. Dutch, Royal Schelde Seaswift- Car Ferry (Artist's Drawing)

Norway

Norway embarked, in 1989, on a five year, \$15 million, research and technology development program funded jointly by Norway's State Scientific and Industrial Research Council (NTNF) and industry. The program addresses four areas; foils, SES, machinery/propulsion and operational safety/economics. The SES section includes ride control, speed loss in a seaway, seal technology, cored GRP construction and noise & vibration. Model tests of a **90-meter** cargo carrying SES (1000 tons) and a side-by-side run of a catamaran and an SES ferry from Kirkeness to Murmansk in heavy seas are examples of funded efforts related to SES. The aim of the safety studies is to modify the IMO requirements for advanced craft. This is being addressed by **DnV** and Norway's **Maritime** Directorate. The overall objectives of this program are more economic than technological, as all efforts are focused on improving the competitive position of the Norwegian fast craft builders.

Ulstein International, in cooperation with Brodrene Aa, has been studying the feasibility of a 55 to 60 meter passengers-only ferry that would provide better seakeeping by simply being larger. Initially, they are looking at 450 passengers which is the current IMO limit.

The Royal Norwegian Navy (RNN), in November of 1989, signed a contract with Kvaerner Batservice A/S to build nine 350-ton SES, cored-GRP, Mine Countermeasures Vessels (MCMVs) (Figure 36); four hunters and five sweepers - with a sixth optional sweeper. A new production facility for cored GRP construction, to 100 meters in length, has been erected in Mandal.

Selection of the cored GRP SES configuration, over the more conventional monohull and catamaran options, was based on extensive analysis and shock testing. The following advantages were cited:

- Major shock attenuation on cushion
- Ability to place shock sensitive equipment higher in the craft
- Reduced acoustic signature
- Reduced magnetic signature
- Improved EMI/EMC associated with the large deck area
- Personnel safety improvements associated with increased space and volume
- A speed advantage of 6 to 7 knots
- Maneuverability
- Stability.

The propulsion system is MTU diesels with waterjets.

The Royal Norwegian Navy is projecting a replacement requirement for more than 20 high-speed patrol/attack craft in the mid 1990s. Their experience with several charter evaluations of the Cirrus 120Ps has established a favorable climate for SES. Since 1989, Cirrus has been developing designs for 33-meter and 42-meter fast-patrol craft. The 42-meter craft, the CIRR 42 (Figure 56) has been selected as the most suitable candidate for the Royal Navy program and has been carried to the detail design and model testing stage. To finance and market the CIRR 42, Cirrus has combined with Det Norske Veritas and IMX, whose specialty is defense marketing, to establish what they have called the Nortest Group. A consortium of equipment and weapons companies has also been proposed to support the prototype, which may begin construction in 1991. The U.S. Navy and U.S. Coast Guard have both received presentations on this craft.

The CIRR 42 is of cored GRP construction with turbine/diesel waterjet propulsion providing a service speed between 50 and 60 knots. Full-load displacement is just over 200 tons. The craft is sized to accommodate an impressive and versatile weapons suit.

Cirrus has developed SES car ferry designs in both 60-meter and 90-meter lengths. The 60-meter design, the CIRR 200P (Figure 55) has been developed to the detail-design stage and has been supported, in 1990, by tests of a manned model. It is understood that a construction contract for the first ship is imminent which would allow construction to begin this year.

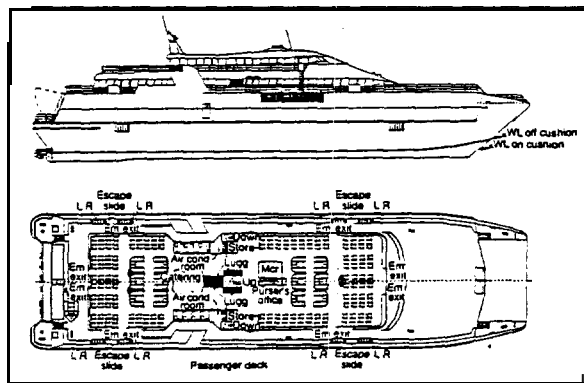

Figure 55. Norwegian CIRR 200P Design

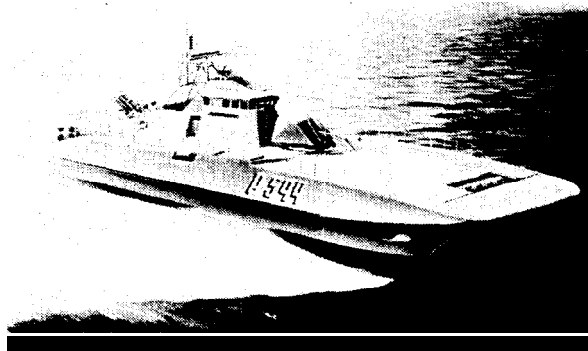

Figure 56. Norwegian CIRR 42 (Nortest)
(Artist's Drawing)

The 200P, with a full-load displacement of close to 500 tons, will carry 364 passengers and 56 cars (typical deadweight of 123 LT). Hull material is cored GRP. The propulsion system consists of twin 6000 hp turbines with waterjets. The lift engines are diesels.

The 200P will meet classification standards of the Norwegian Maritime Directorate, the IMO resolution A 373 (X) and DnV + 1A1R40, Light Vessel SF-F-EO/LC. The car deck is equipped with sprinklers and is isolated from the passenger compartments by a cofferdam ceiling.

Spain

Testing of the BES16 proof-of-concept for the 370-ton BESS0 is nearing completion. The BESS0 design is well advanced at this time (Figure 41). Construction is welded aluminum with propulsion by two Allison 571KF turbines with KaMeWa waterjets. Sustained speeds in the mid 40 knot range are predicted. This program is being executed by an MoD/Bazan/Chaconsa team.

Sweden

In June of 1989 a contract was awarded to Karlskronavarvet by the Swedish Defence Material Administration to construct an SES test craft designated Testrigg (Figure 39). This craft (called the SMYGE, which means to sneak or smuggle) is intended to evaluate stealth optimization, new weapons systems, cored GRP construction, the SES concept and waterjet propulsion. SMYGE is considered a test platform for future MCMs as well as combatant craft. Construction should be completed in 1991.

Cored GRP construction was selected for reduction of weight, cost and magnetic and infrared signatures. Waterjets provided significant improvements in acoustic signature. The SES concept was considered to provide the best platform for a multi-mission craft. SES "pros" were; seakeeping, resistance, area/volume, pressure signature, hydroacoustic signature, shock resistance and draft. SES "cons" were; increased cost, sensitivity to trim and overload and vulnerability to ice.

The 145-ton Testrigg SMYGE is 100 ft overall with a beam of 37 ft. Speeds to 50 knots are attainable with two MTU diesels and KaMeWa waterjets (Reference 18).

United Kingdom

Initial designs of the Hovermarine '700" series were developed in the early 1980s. The concept, described as the "Deep Cushion" craft, provides a cushion depth

of 20-ft or more on a 60-meter SES, an approach demonstrated by a manned model (Figure 57) to provide reduced motions' in high sea states.

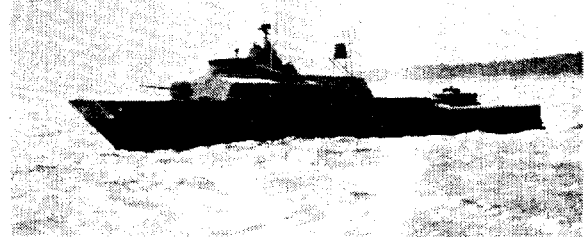

Figure 57. Manned Model of Hovermarine Deep-Cushion Craft (UK)

The 262-ft HM780 carries a payload of 750 passengers and a typical vehicle mix of 77 cars, 5 coaches and 8 light vans (239 tonnes). The entire craft is welded aluminum for a full-load of 850 tons. Propulsion is two Rolls Royce Spey SM2 turbines with KaMeWa waterjets. The HM780 is capable of operating at 48 knots in 1 0-ft seas.

Hovermarine International are also marketing the 82-ft HM 424, a 165 to 200 seat passenger-ferry design in GRP capable of speeds up to 50 knots depending on engines selected (Reference 6).

United States

In the United States, Textron (Bell), Lockheed, Trinity, Newport News and Ingalls have all recently developed designs of large SES. Textron has a design for an SES car ferry reported in Reference 5. The leading particulars of this SES are listed in Table 2. The Trinity Marine Group has a design for a passenger ferry developed as a derivative of the Bell-Halter BH-110 (Figure 58). Trinity is also marketing a larger high-speed passenger ferry for operation on the Eastern Seaboard and a 115-ft SES motor yacht (Figure 59). Lockheed, Newport News and Ingalls have each developed SES conceptual designs as candidates for the US. Navy's Fast Sealift requirement. Band, Lavis & Associates, Inc. (BLA) has also developed an SES car-ferry design (Figure 62, Reference 26) a 70-knot Mega-Yacht SES design, (Figure 60, Reference 27) and an SES design (Figure 61) as a possible future candidate for consideration as a 70+-knot Trans-Atlantic, Blue-Riband, Challenger.

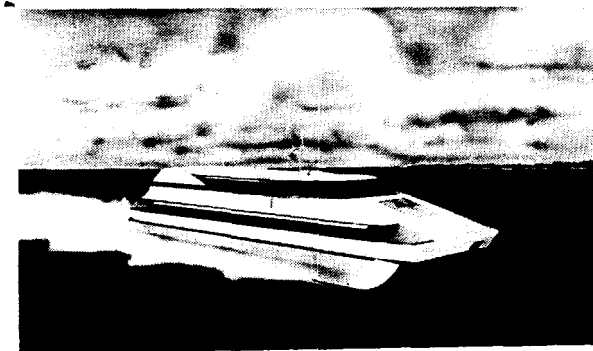

Figure 58. Artist's Drawing of Trinity SES Ferry (U.S.)

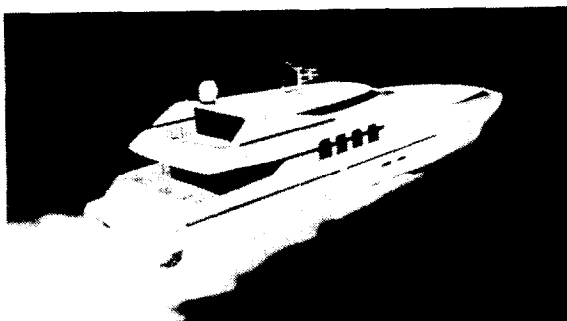
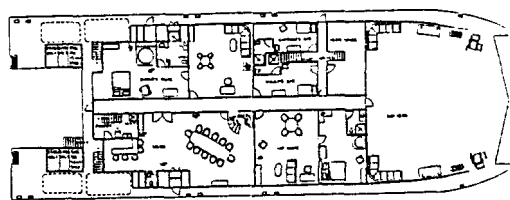
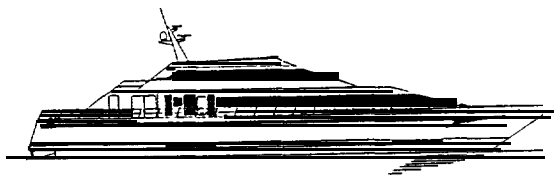
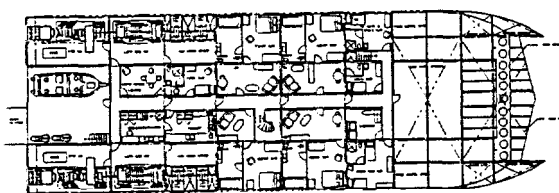

Figure 59. Artist's Drawing of Trinity SES Motor Yacht (U.S.)



MAIN DECK



SECTION DECK

Figure 60. BLA SES Mega-Yacht Design (U.S.)

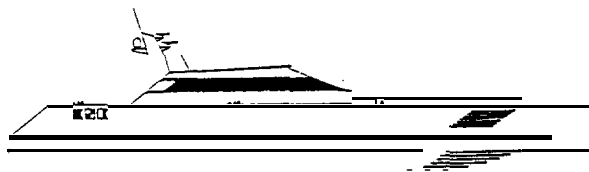

Figure 61. BLA SES Blue-Riband Challenger Design (U.S.)

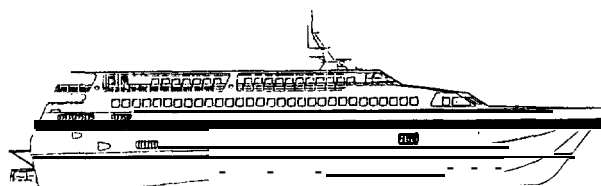

Figure 62. Outboard Profile of BLA SES Passenger-Car Ferry

USSR

In the Spring of 1990, the world's largest SES was commissioned by the Soviet Navy after a year of sea trials (Reference 16). The Dergach was built at the Kamysh-Burun Shipyard in Kerch on the Black Sea. A second SES of the class is under construction.

Propulsion and lift power for the 650-ton Dergach is provided by three gas turbines. Armament consists of two SS-N-22 quad launchers, twin SA-N-4 Gecko missile launchers, a 76.2 mm gun and two 30 mm Gatling guns (see Figure 26).

Summary

Since 1961 there have been over 50 SES designs which have been built as test craft, or as prototypes which have lead to quantity production. Figure 63 shows the number of the most prominent SES of a new design launched each year. The numbers include only the first in any series production and craft having major modifications.

Figure 63 shows, clearly, the significant increase in world-wide activity in the last ten years.

The annual breakdown by regional group is shown in Figure 64. The three groups are (1) the United States, (2) China, Korea and USSR, and (3) Europe. This shows that the majority of the recent growth in activity is in Europe followed by the group of China, Korea and USSR. In the US., only four new designs have been built since 1980.

Number of SES of a New Design Launched Each Year

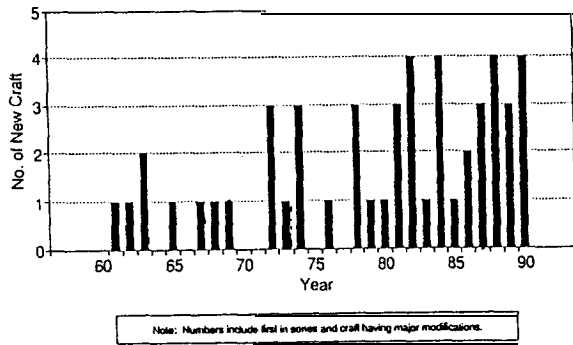

Figure 63. SES Prototypes
Number of SES, by Region, of a New Design, Launched Each Year

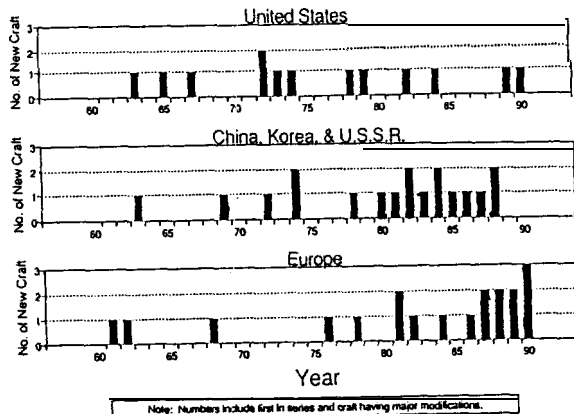

Figure 64. SES Prototypes by Region

The growth in the world's market for fast ferries is illustrated in Figure 65. This growth has been met by hydrofoil craft, catamarans, monohulls, SES and ACVs with SES now taking an increasingly larger share.

Number of Fast Ferries Delivered 1970-1990 (Ref. Fast Ferries, RINA, Dec. 1990) Paramilitary Vessels Excluded

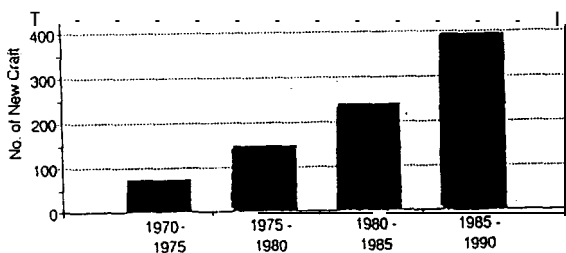

Figure 65. The Fast-Ferry Market

The competition is fierce and SES can only be justified on routes where high speeds, generally over 40 knots, are of interest.

SES CHARACTERIZATION

The Name

Air-cushion supported craft, generally referred to as "Hovercraft," have been known by a variety of names: the amphibious type that is fully supported by the air cushion has been called the "Ground Effect Machine" (GEM, now obsolete), or "Air-Cushion Vehicle (ACV - now in general use in the USA); while the type in which the air cushion is partially contained by catamaran-like hulls has been called the "Captured Air Bubble" (CAB, now obsolete) the "Air-Cushion Catamaran" (still in use in Scandinavia) or the "Surface Effect Ship" (SES, now in general use, particularly in the USA), and which is the subject of this paper.

Why SES?

Although the SES has a number of unique advantages, the principal motivation behind the SES concept is that the air cushion, which supports the majority of the weight of the craft, significantly reduces craft resistance to forward motion at high speed and helps to mitigate the effect on craft motions and accelerations of operating in rough seas. Although power is required to create and sustain the air cushion, the reduction in resistance is so large at high speed that the sum of lift and propulsion power is significantly less than the propulsion power of the equivalent conventional craft.

This feature (discussed in more detail later) is illustrated in Figure 66, in which total installed horsepower per ton (of full-load displacement) is plotted against design-speed Froude Number (v/\sqrt{gL}). The open symbols represent SES and the black symbols represent monohulls. The data points are for craft which have successfully operated or (as in a few cases shown) have been the subject of detail design. Curves have been drawn in Figure 66 to bound the lower extremes of the data for each of the two types of craft. These curves on Figure 66 are labeled "state-of-the-art" and show that, beyond an overall-length Froude Number of about 0.75, the SES has an increasingly distinct advantage in total power despite having to provide power for lift.

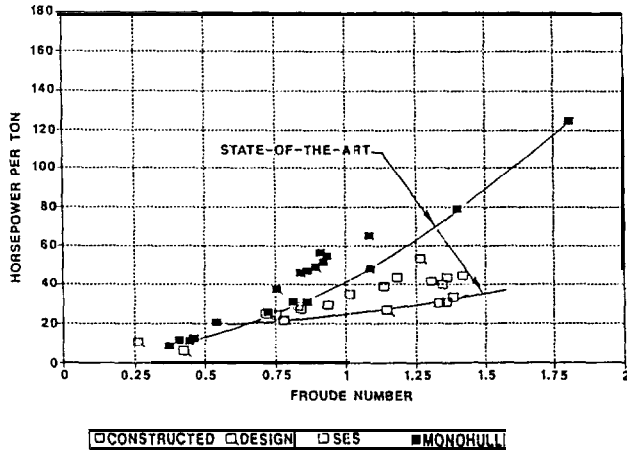

Figure 66. installed Power/Full-Load Displacement Versus Froude Number

For the data shown in Figure 66 “speed” is the maximum continuous speed obtainable at full-load in calm water (and still air). The comparison changes somewhat for operation in rough water in favor of the monohull.

The SES has flexible seals at the bow and stern that span between the sidehulls to impede the loss of cushion air fore and aft. These seals are designed to minimize air loss from the cushion by tracking the surface of the waves. For high-speed operation in rough water the seals (in particular the stern seal) have more difficulty in containing the cushion. The consequence is that, as sea state increases, more cushion air flow is lost and cushion pressure is reduced. The side hulls are then required to carry a larger fraction of the weight, they operate with a higher time-average draft and, hence, with more wetted area which results in an increase in drag. At the limit, the operation of an SES approaches that of a catamaran. Fortunately, this is usually a gradual process with increasing sea state but can result in a larger, involuntary (constant power), speed loss in very rough seas as compared to conventional craft. This feature of the SES applies particularly to operation in head seas and to a lesser extent in beam seas and following seas.

When the significant wave height reaches about twice the height of the cushion (i.e., twice the height from keel to wet-deck) the SES ceases to have a powering advantage over conventional craft. However, in such conditions, speed is usually voluntarily limited by craft motions (particularly for a conventional craft) so this loss in advantage has not been found to be significant.

For some conditions, cushion flow rate can be deliberately reduced to improve performance. This occurs when high sea states cause operation to occur near hump speed (see Figure 67) at which a reduction in cushion pressure can significantly reduce cushion wave drag, albeit with an increase in sidehull drag.

The corresponding reduction in lift power (due to reduced air flow and pressure) combined, in the case of **waterjet** propulsion, with an improvement in propulsive efficiency due to having the inlets operate with a deeper draft can, within limits, result in an overall reduction in total power. This can also cause, in some cases, a reduction in pitch motion due to increased damping from the sidehulls (as explained by Lewthwaite, Reference 19).

The performance of an SES, and other **high**-performance craft, is also more sensitive to weight than that of conventional low-speed craft. Thus, there is always a motivation to find acceptably-reliable subsystems of minimum possible weight albeit at a higher price. This has **been** construed, in some circles, as a major disadvantage for SES. However, we prefer to view the SES as a craft that can take cost-effective advantage of using light-weight systems unlike most other marine craft (and particularly unlike Monohulls). What seemingly little motivation there has been in the marine industry to develop lightweight systems (for power plants, transmission systems, structures outfitting, auxiliary systems, etc.) has resulted, however, in very significant progress over the years, and at a rate which is continuing. Without high power-to-weight diesel **engines** and the use of aluminum alloy or foam-core **GRP** for hull structure, all of the total power-to-weight advantage of SES, shown in Figure 66, would not have been possible. As further progress is made to develop even lighter systems the advantage for the SES will increase.

SES Geometry

The features of an SES which set it apart from conventional craft are:

- a. The air cushion, formed by the two hulls on either side of the cushion and the flexible seals at the bow and stern
- b. The lift-air-supply **system** consisting of engine, power train, fan(s), air-distribution **ducting** and a ridecontrol system if **installed**.

Other features required for propulsion, steering, stability and **onboard** systems are generally similar, to those of conventional monohulls or catamarans.

The Cushion

The choice of the length, L_c , and breadth, B_c , of the cushion is influenced by many factors foremost of which is their effect on the wave-making drag of the cushion which, at some speeds, can be a large fraction of the total drag of the craft.

Figure 67 shows how the predicted non-dimensional cushion wave drag, for deep water, varies with changes in Froude Number and the ratio of cushion length-to-beam (L_c/B_c). For L_c/B_c ratios less than about 5 a significant "bucket" exists between the so-called primary and secondary drag humps at Froude Numbers (based on cushion length) of between 0.4 and 0.7.

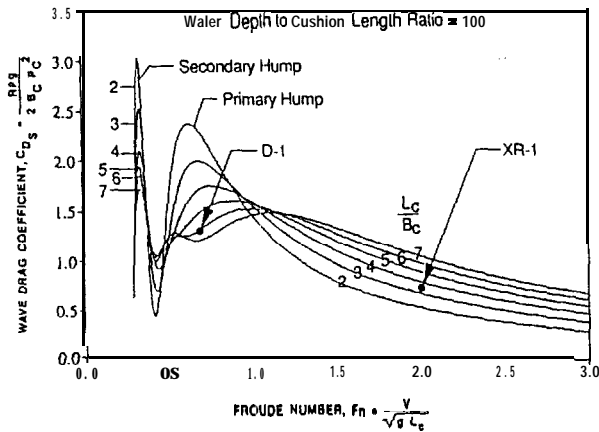

Figure 67. Cushion Wave-Drag Parameter Versus Froude Number

It would be natural, of course, to avoid cushion dimensions which would cause the craft to operate close to either of the secondary or primary humps, so dimensions are usually chosen to have the craft operate either in the drag bucket or at speeds above the primary hump. This is illustrated in Figure 67 by the choice of L_c/B_c ratios of approximately 6.0 and 3.5 for the low-speed D1 and the high-speed XR-1, respectively.

If the craft is relatively small and has a high design speed, then a low L_c/B_c is usually favored to obtain low drag in the post-primary hump condition. This is the usual choice for small high-speed passenger ferries or for small very high-speed military craft that spend most of their time underway at cruise speed.

If the craft is large and has a low to moderate design speed then a high L_c/B_c is usually favored to obtain

low drag in the so-called "drag bucket". This is the usual choice for most military craft which also allows for lower drag, and more economical operation over a wider range of speeds (Reference 24).

However, selection of cushion area and L_c/B_c ratios is not based entirely on wavemaking resistance. Factors such as overall craft size, dictated by payload-deck area and limited by docking or construction limits, can play an important role. The choice of length and beam also affects seakeeping, dynamic stability, static stability, arrangements, structural loads and costs. Generally, seakeeping in head seas is improved with increasing craft length. Increasing craft beam increases maneuverability and lateral stability or allows for a deeper cushion to minimize wet-deck slamming and results in a higher freeboard to minimize deck wetness. This is illustrated by Figure 68 which shows platform acquisition cost versus cushion length and beam. Similar plots can be produced for power and full-load weight. Figure 68 is a carpet plot produced using a whole-ship SES Design Synthesis Model (References 25, 26 and 27) which integrates the effects of resistance and powering, structural loads, material properties, stability, seakeeping, as well as sidehull shaping and volume for waterjet pump installations among many other considerations. Estimates of the acquisition cost depend upon factors such as design cost and labor and material cost for construction.

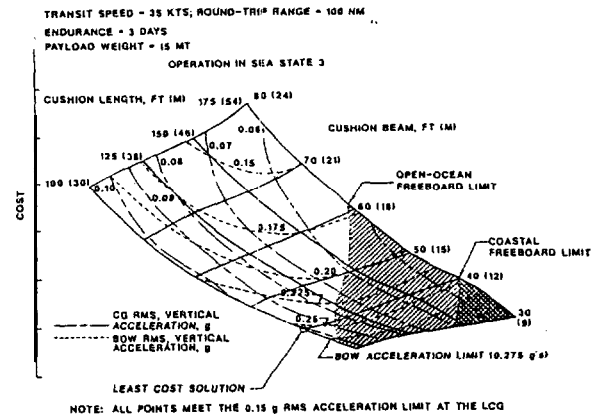

Figure 68. Typical Plot of Cost Versus Length and Beam for an SES

The results of the seakeeping predictions for this example are overlaid on Figure 68 as lines of constant rms vertical acceleration at the bow and cg of the craft. The design point selected represents the least-cost craft with acceptable ride quality and performance.

A further explanation of this figure is given later in the paper under the subject of "Design for Seakeeping."

Sidehulls

Figure 69 illustrates a typical midship cross-section of an SES. The terminology used to define the various dimensions are those in common use, at least in the USA. A corresponding perspective view of an SES hull, without seals, is illustrated in Figure 70.

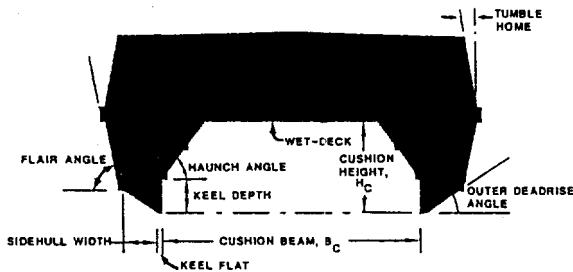

Figure 69. SES Midship Geometry

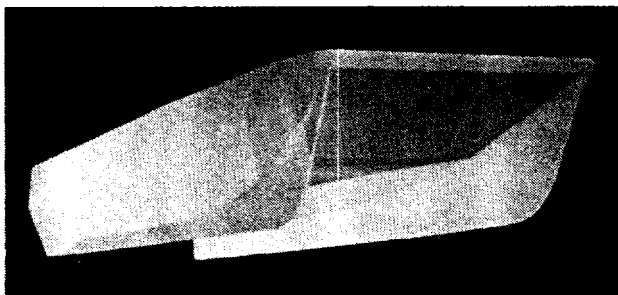

Figure 70. Perspective View of an SES Hullform

Sidehull geometry is selected primarily to provide satisfactory on-cushion performance, stability and seakeeping based on prior experience. Figures 71 and 72 illustrate the wide variety of sidehull shapes that have been used in the past. Some of the features exhibited by current trends include:

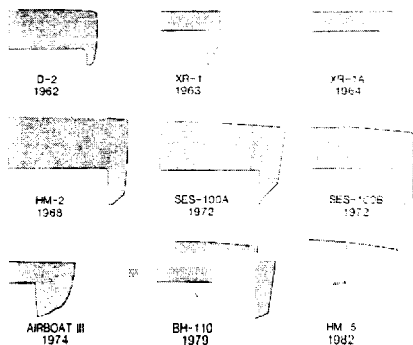

Figure 71. Early Trends in Sidehull Mid-Ship Sections

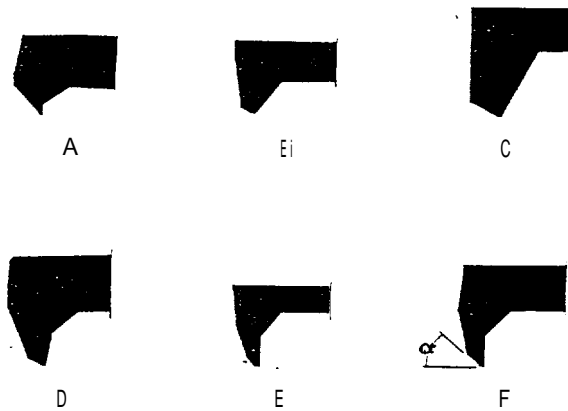

Figure 72. Recent Trends in Sidehull Midship Sections

- High cushion heights, with the ratio of cushion height to beam amidships, in some cases, greater than 0.35 (with even a larger value forward) to minimize slamming of the wet-deck both on and off-cushion.
- Sidehulls having a fine entry forward to reduce resistance and to reduce pounding and pitching in moderate seas but incorporating flare to increase lift during bow submergence in heavy seas with rails inboard and outboard (shown in Figure 69) to minimize spray.
- A keel flat for docking and an outer deadrise surface (of 30 to 45 degrees to the horizontal), for a significant length of each sidehull to develop sufficient dynamic lift during high-speed turning maneuvers to prevent roll out.
- An internal haunch to the sidehull to increase sidehull displacement, to minimize draft off-cushion, maximize wet-deck clearance off-cushion and to provide extra space for machinery installed in the sidehulls. A relatively fine entry forward but a relatively abrupt change in section aft for the haunch will minimize resistance.
- A wider keel flat, wider deadrise surface, or reduced deadrise aft to accommodate a flush, or semiflush, waterjet inlet with gradual changes in sectional shape ahead of the inlet sometimes combined with inboard and/or outboard fences to impede the cross flow of air to the waterjet inlet.

Recent trends in **sidehull** geometry are also illustrated by the range of dimensional and non-dimensional parameters shown in Table 3.

Table 3

Range of Hull Characteristics of SES Designs

	High	Low
Overall Characteristics		
Cushion Length to Beam, $\frac{L_c}{B_c}$	7.0	2.0
Freeboard/Beam Overall, $\frac{D}{B}$	0.5	0.25
Cushion Height to Beam Overall, $\frac{H_c}{B}$	0.3	0.1
VCG Height to Beam Overall, $\frac{KG}{B}$	0.4	0.2
Cushion Pressure to Length, P_c/L_c , lb/ft ³	3.0	1.0
Cushion Density, $W/(A_c)^{1.5}$, lb/ft ³	6.0	2.0
Sidehull Characteristics:		
Length to Beam Ratio, $\frac{L_{WL}}{B_s}$	26.0	17.0
Hullborne Beam to Draft Ratio, $\frac{B_s}{d}$	1.45	0.70
Gap Ratio, $\frac{B_H - 2B_s}{L_{WL}}$ (B_H = Maximum Craft WL Beam Hullborne)	0.24	0.10
Prismatic Coefficient, C_p	0.89	0.60
Block Coefficient, C_b	0.74	0.54
Displacement/Length Ratio, $\frac{W(\frac{1}{2})}{(0.01 L)^3}$	49.0	27.0
Deadrise Angle Amidships, α	45°	30°

3.3.3 Cushion Seals

The current status of SES seal technology can be considered in terms of 30 years of operational experience with both military and commercial SES and **ACVs** up to 300 tons and a large body of test data and analysis on seal systems for high-speed, high-cushion-pressure, ocean-going SES (e.g., 3KSES and related studies).

An analysis of the history of seals development reveals three basic design approaches that have been taken towards meeting the cushion sealing requirements for **ACVs** and **SESs**. They are as follows:

- Flexible Membrane Seals
 - Bag-and-finger (SRN-series, SES-1006, LCAC, LACV-30)
 - Loop-segment (Vosper VT1 and 2, HM-series)
 - Full-depth-finger (**BH-1 10**, SES 200, **Norcat**, Jet Rider)
 - Loop-Pericell (AALC JEFF(A))
 - Multi-lobe stern seals (most SES)
- Semi-Flexible Reinforced Membrane Seals
 - Stay-stiffened membrane (SES-1 OOA, XR-1 C)
 - Transversely stiffened membrane (Early SES 200)
- Semi-Rigid Planing Seals
 - Bag and planing surface (XR-1 D)
 - Bag and segmented planing surface (SES-1 00A1, 3KSES).

The most common types of SES cushion seals used today are:

- Full-depth, or bag-and-finger, bow seals
- Double or **triple-lobe** stern seals.

All **are**, essentially, two-dimensional, **flexible**-membrane seals using varying types of **elastomer**-coated **fabric** (usually neoprene or natural **rubber**-coated nylon fabric) weighing between 40 and 100 oz per sq. yd. depending on craft size and duty.

All are highly compliant, responsive, low-drag cushion seals, while the bag of a bag-and-finger bow seal acts as an air-distribution duct and provides increased restoring moments and protection for the local structure from slamming when encountering large waves. Additionally, finger seals provide a high level of redundancy in that the failure of individual fingers is largely compensated for by expansion of the adjacent units.

The longitudinal location of the bow and stern seals on the craft defines the cushion length and center of cushion **area**, which must be carefully selected to be fairly close to the craft's longitudinal center-of-gravity for correct trim. At high speed, an out-of-trim condition by as little as **+5%** of the cushion length can increase drag **significantly**. Thrust contributions to pitching moments **must** also be taken into account.

Bow-down trim will reduce directional stability and can cause a higher likelihood of propulsor broaching. Bow-up trim will reduce maneuverability and may increase vertical accelerations in a seaway.

Bow-Seal Geometry

The fingers of a full-depth-finger bow seal or of a bag-and-finger bow seal are inflated by cushion pressure.

The bag of a bag-and-finger bow seal is inflated to a pressure 10% to 15% higher than cushion pressure using fan-supplied air ducted within the hull structure (usually using space available in the double bottom of the cross-structure). An illustration of a bag-and-finger bow seal is shown in Figure 73.

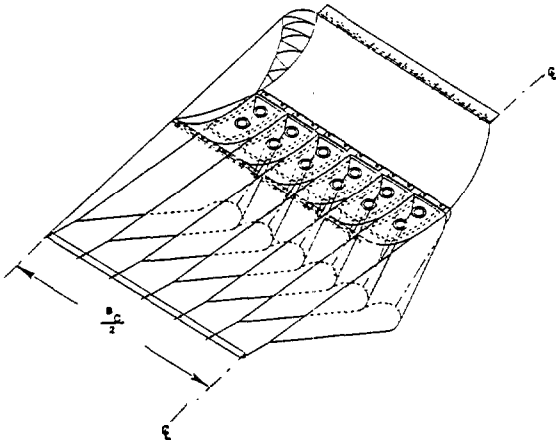

Figure 73. Illustration of Bag-and-Finger Bow Seal

The fingers shown in this figure are similar in concept to those used for full-depth finger seals.

The exterior angle between the water surface and the external forward face of the finger, can greatly affect craft heave and pitch stiffness. The smaller the angle, the greater the stiffness but the smaller the cushion area.

Also, at small exterior angles, there is a tendency to increase wetted length; therefore, there is an increase in drag plus a greater tendency for the fingers to scoop when the craft is moving astern. At large angles, the resulting increase in cushion area is offset by slower finger recovery after deflection and increased difficulty in providing a practical configuration for long support webs. Angles from approximately 45 to 50 degrees are considered to be optimum.

The included angle formed by the outboard forward side of the finger and a line from the inboard attachment to the tip of the finger, should preferably be 90 degrees to generate a **satisfactory** geometry which will inflate properly to the desired configuration. Normal cushion pressure acting on the finger's surfaces generates tension in the semi-cylindrical outer face. This tension is supported by the finger webs which are in turn attached to the **hull** or primary loop. As the included angle is allowed to fall below 90 degrees, the section of the finger that is between the top and the **90-degree** intersection is no longer supported in direct tension. It, therefore, has to rely for stability on shear resistance from the elastomeric coatings, plus a degree of interlocking from the loaded warp and fill threads. A form of instability occurs when the tension loads can no **longer** be supported in this fashion and the lower **unstable** finger area is free to extend outwards. Fingers with a tip angle in the range of 80 to 90 degrees will, however, perform satisfactorily if fabric stiffness and/or shear resistance in the lower finger area are adequate.

The ratio (expressed in terms of percent) of finger depth to cushion depth for a bag-and-finger seal can greatly affect seakeeping. Increasing the depth of the finger reduces the rough-water drag, but with a penalty of reduced stability and, generally, reduced cushion area. Originally, one of the objectives of selecting a combination of bag and secondary skirt was to provide replaceable sections in the area subjected to the highest wear and abrasive action. Finger life on high-speed SES is typically 500 to 1000 hours, or six months of **commercial** service, before refurbishment is required.

Early bag-and-finger designs used a 30% **finger-to-cushion** depth ratio; however, the bag was often in contact with green water while the craft was operating over waves. Since then, there has been a steady growth in finger depth percentage, and current bag-and-finger bow seal **designs** for most **ACVs** and SES have finger depths from 50 to 70%.

A depth-to-width ratio of approximately four has been established for open finger segments based on model test and full-scale development. There is evidence that relatively wide fingers **are** more susceptible to scooping loads when backing up. This is attributed to the larger hoop tensions and vertical resistance of wider fingers. On the other hand, very narrow fingers or cells suffer from poor **recovery** and temporary hang-ups in conditions where large deflections occur.

A bow seal should respond to the waves, but not collapse or tuck-under. The basic aim is to prevent the bag from distorting appreciably, as a result of water contact drag, and thereby moving aft and under the craft with a consequent loss in cushion area and restoring pitch moment. Increasing the bag's resistance to deformation is achieved by choice of inflated radius, pressure, and location of attachments to the hard structure. Several design approaches are available to meet these requirements. First, the shape of the bag in **planform** is curved or bowed out as much as possible (to create a three-dimensional effect) within the limits of any craft-length restrictions. This creates additional longitudinal stresses in the bag, which in turn leads to a stiffening effect under bag deformation. Next, the outer attachment of the loop can be raised as far as possible to increase the outer loop radius and the hoop tension and thereby reduce the tendency for collapse during wave contact.

Stern-Seal Geometry

An illustration of a three-lobe stern seal is shown in Figure 74 installed between the vertical and parallel sides of the inner surface of the sidehulls aft.

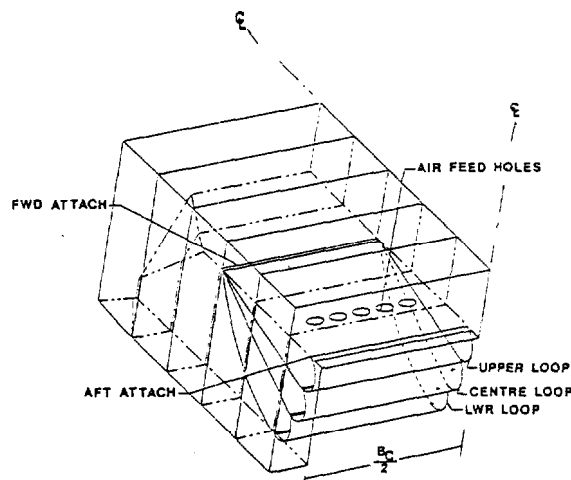

Figure 74. Illustration of Triple-Lobe Stern Seal

It is generally recognized that stern seals should be intentionally more sensitive to **lifting** forces and pressure changes than bow seals since compliance is required to allow effective contouring of the waves for efficient cushion sealing and to reduce drag and wear loads.

Stern seals are either fed by the main air supply, a separate air supply, or via a boost fan which takes cushion air and increases the steady or time-average pressure to a pressure of from just above the time-average cushion pressure in rough water to as high as 30% above cushion pressure in calm water.

Stern seals can be prone to flutter due to the air passing under the trailing edge causing an unsteady state at the surface and causing the seal to oscillate. Typically this is more of a problem in calm water. This can be corrected by adding devices to the wear strip to break up the air-flow patterns. Studies utilizing the LCAC and the LAW-30 with small reinforced elastomer-coated fabric planing surfaces on the stern seals proved very effective in reducing drag and reducing stern-seal wear. UK (Hovermarine) experience is that conventional stern seals for SES have wear lives of several thousands of hours.

The geometric layout of the stern seal requires a similar approach to balancing the forces with cushion pressure, seal pressure and system weight as for the bow seal. Mathematical models can be used to analyze the two dimensional geometry under various loading conditions. A key design consideration for the stern seal is rapid response to waves to minimize cushion leakage at high forward speed. This requires careful design of the air supply and exhaust system to ensure that when the seal is compressed the bag pressure is dissipated and then rapidly replenished to restore its seal to the deployed position.

To allow adequate freedom of movement, but to prevent excessive air leakage, the total width of the stern seal must be carefully tailored to achieve a small clearance between the outboard edge of the seal and the vertical sides of the sidehull at the stern.

Cushion-Air-Supply Systems

The cushion-air-supply system of an SES is designed as an integral part of the design of the *craft*. Initially, emphasis is on the quantity and location of lift air required, the cushion pressure and hence, the lift power required.

Cushion Air Flow

Flow is generally split between the cushion, bow seal and stern seal in the approximate proportions of 65 to **75%**, 15 to 20% and 10 to **15%**, respectively. Even if a full-depth finger bow seal is used, air is usually fed forward to a transverse manifold in the structure of the

hull to discharge air through the wet-deck above each individual finger. Air fed directly to the cushion is also usually discharged through the wet-deck at a forward location on the craft.

There are several formulations in current use for the calculation of required total air flow. These **methods** use different approaches for **the** calculation and give somewhat different results depending on the Craft size, speed, sea state and length-to-beam ratio. Some judgment is **required** in selecting the **design-point** lift-air flow.

Usually a compromise is made which is neither the highest or the lowest flow calculated. If a ride-control system is to **be** used, the normal design flow for the cushion is increased in some cases by up to 30%. For a **200-ton** SES the total air flow **rat8** would be about 3000 to 4000 cfs depending on design speed and the cushion pressure would be a little less than 1 psi.

Cushion Pressure

At design speed in calm water the cushion would be **expected to support at least 85%** Of the weight Of the SES (although existing craft have values ranging from 75 to 90%). When operating in head **seas** having a significant wave height equal to the height of **the** cushion, **the** cushion would be expected to contribute only about 50% of the time-average lift (depending, primarily, on the efficiency of the stern seal); the **other** 50% would be **contributed** by the sidehulls. Thus, the time-average cushion pressure, in this **case**, would vary from 85% to 50% of the weight of **the** SES divided by the cushion area, which is the product of cushion length and cushion beam.

Types of Fan for SES Use

The most common arrangement has centrifugal fans in rectangular-section **spiral-volute** casings driven by **diesel** engines. In a few **cases**, axial fans have been employed, but generally centrifugal fans have proved to be superior **because** of their relatively flat, **essentially** stall-free pressure-versus-flow characteristics and simple, **rugged** mechanical **design**.

There **are** several **types** of **centrifugal fans** which can be considered. The most common and successful so far is the backwardly-inclined, **airfoil-bladed** centrifugal fan specially adapted for SES use. This general **type** of fan is **widely used** in large ventilating systems and other industrial applications, where it is **valued** for its

high efficiency, relative **quietness** and simplicity of design. For SES use it has **been** found advantageous to design **the** fan impeller with a narrower blade width and a somewhat higher blade angle than is usual for its industrial counterpart. These features enable the fan to be designed for higher pressures without exceeding structural limitations while retaining a high flow capacity.

Detail Design Features of Lift Fans

The detailed design of lift fans requires special attention to features that **have** significant effect on fan performance. One of **these** features is the interface between the inlet bellmouth and the impeller shroud. The shaping of the inlet **bellmouth**, the shroud, and the clearance between them, have a profound influence on the pressure-flow characteristic, the design flow capacity and the efficiency of the fan. Another feature is the volute **size** and shape and the cut-off lip configuration. **Volutes** of different spiral angles and forms have been tested including arithmetic and logarithmic log spirals, circular arc and composite forms. The **shape** of the cut-off lip and its clearance affect **the** fan characteristics and the noise produced.

Fan Pressure-Flow Characteristic Shape

It is desirable that the fan or fans produce a flat pressure-flow characteristic. The reason for this is that the vessel's heave stability and the comfort of **the** **rid8** are **affected** by **the** slope of the pressure-flow **curve** at the fan operating point. It is desirable that the pressure-flow curve should have a low negative **slop8** at the fan design operating point which should be coincident with the maximum fan efficiency. Off-the-shelf **fans seldom** satisfy **these** two conditions simultaneously, **i.e.**, low slope and peak efficiency. Fan performance in a dynamic environment is discussed in Reference **28**. Limitations for large SES applications are discussed in **Reference 29**.

Lift-Fan Power Transmission

With regard to the fan power transmission, it is frequently possible to use direct drive from a diesel engine to the fan coupling. Sometimes two fans may **be** connected in series to the same lift engine. Some **diesel** engines permit power to be **taken** from both ends of the crank shaft, thus, a fan may be driven from each end of the same engine. Almost invariably, **SESs** us8 double-width, double-inlet fans rather than larger single-width, single-inlet fans, with a **conse-**

quent saving of space, weight and cost and generally with a better speed match to the engine.

Due regard must be paid to the dynamics of all drive systems including diesel engine and fan combinations. Improper shafting and coupling designs can lead to serious torsional oscillations.

Usually the diesel engine torque characteristics will be found to be well-suited to lift-fan operation but it is necessary to plot on the H-engine map the fan torque-and-power demand **curves** for all foreseeable modes of operation of the ship to ensure that the engine is not overloaded under any normal circumstances.

Failure Modes

Special cases which must be considered for lift-system operation include engine or fan-failure modes. **Lift** fans are often fitted with shut-off vanes which are normally fully open and are of airfoil shape for minimum flow resistance. In the event of fan or engine failure the vanes may be closed to prevent loss of cushion air and windmilling of the fan. The design and location of these vanes for minimum loss and maximum sealing is a special part of the lift-system design.

Lift-System Performance

Lift system performance is handled best by a mathematical model of the entire lift system. Such a math model is particularly desirable if an integrated lift and propulsion system is to be used.

The lift system math model represents the entire flow path of the air from the atmosphere, taking into account ship speed, wind speed and direction, inlet grill and other inlet losses, possible ram recovery, pressure rise through the impeller, exit vane losses, duct losses to bow and or stern seal, direct flow losses to the cushion, flow losses from the seals to the cushion, and from the cushion to atmosphere. The model takes into account changes of cushion and seal pressures due to variations of craft displacement, **sidehull** immersion, fan speed, ambient air conditions (temperature, pressure, humidity and wind velocity). If cushion air is used for bow-thruster purposes (for maneuvering and control) then the bow thruster and its control vanes are also modeled. The engine characteristics are modeled so that changes of fan speed reflect changes of fuel consumption and other

engine parameters as well as fan pressure, flow and horsepower. Such a model can provide a complete picture of lift-system operation for all quasi-steady operating conditions foreseeable.

In summary, it may be stated that lift-system design is a fairly mature art, but attaining optimum performance and efficiency depends on extensive experience and skill on the part of the designer.

SES Resistance

An understanding of the performance of SES has been slowly and painfully acquired within the community over the last thirty years through innumerable design studies, model tests, full-scale trials and operational experience. This has now matured to the point that reliable performance predictions can be made for new designs which conform rationally to the established principles which have been formulated.

The resistance of an SES, like that of other marine **craft**, is the sum of several elements which include the following:

Cushion Wave-Making Drag

Several theoretical formulations have been made for the resistance of a pressure distribution moving over a free surface, including those of Newman & Poole (Reference 30) and Doctors (Reference 31).

Sidehull Drag

Sidehull drag is composed primarily of **sidehull** wave-making and frictional components. Since, *in* very rough water, the average support from the sidehulls can increase to **50%**, or more, they have the equivalent hydrodynamic resistance of **similar**-catamaran-like slender hulls. The main difference being that the average water level is lower on the cushion side of the **sidehull** due to the cushion pressure. For **ACVs**, rough-water drag can be predicted as a function of sea-state modal period, and this relationship has recently been perfected for SES (Reference 55).

Appendage Drag

SESs may have appendages in the form of rudders, stabilizing fins, or waterjet-inlet fences and, if propulsion is by means of marine screws, there may be shaft and bracket appendage drag also.

Seal Drag

The seals of an SES are seldom fully out of contact with the water, even in calm water and at high lift-system power settings. In waves and at all normal operating conditions the fabric tips of the fingers which form the seal will make a brushing contact with the water and create drag.

Spray Drag

Sidehulls will generate spray which can be controlled, to some extent, by external and internal spray rails. Also, the air escaping under the seals generates considerable amounts of spray. Spray which impacts any part of the craft adds to the drag.

Momentum Drag

If there is any relative motion between the craft and the ambient air, as in normal forward motion, or otherwise, there will be a momentum drag associated with the lift-fan flow for the cushion, and other, less significant, air flows to the engines and ventilating systems, etc.

Likewise, as with most marine craft, any cooling water or water for other purposes, which enter intakes on the sidehulls, contributes to momentum drag. However, if the SES is propelled by waterjets the waterjet-inlet momentum drag is charged to the propulsor and does not enter into the total ship-resistance calculation. Other types of waterjet-inlet drag are part of the appendage drag of an SES.

Aerodynamic Drag

Because of their potential for high speed the aerodynamic drag coefficients of **SESs** must be determined so that aerodynamic drag may be calculated. If the craft is experiencing a head wind, and has a high water speed., the effective air speed can result in significant aerodynamic drag.

Drag Prediction

Predictions of resistance can be made analytically using a combination of theory and empirical knowledge and experience. Such predictions are most useful in parametric design studies such as those which use a design synthesis model (Reference 25). However once a point design has been identified it is customary to confirm the resistance predictions by means of tow-tank model tests.

Tow-Tank Tests

Tow-tank model tests are usually conducted for a range of Froude-scaled speeds in calm water and scaled **sea** states. Other parameters which should be correctly scaled include model weight, pitch radius of gyration, trim, lift flow and seal pressures. The model is usually free in pitch and heave and may also be free in surge. Self-propulsion tests may also be conducted. Many variations on the basic resistance tests are possible.

The tow-tank resistance data must be corrected for Reynolds number and tank effects when scaling to full-size craft resistance. Underwater photos are helpful in determining **sidehull** wetted area, since the skin frictional resistance of the sidehulls has to be corrected. Aerodynamic drag of the model may also be measured **approximately** by towing the model fixed in heave and clear of the water or, more precisely, by using a separate wind-tunnel test. Tow-tank models do not operate at the appropriate Reynolds Number and seldom represent the profile of the full-scale craft accurately, so they can only give an approximate estimate of the aerodynamic drag. For very high-speed craft, the aerodynamic drag is best determined from wind-tunnel tests.

Propulsor Installation Effects

Due to installation with respect to the free-stream **flow**, marine propulsors suffer a loss of apparent thrust which is reflected by the so-called thrust deduction factor (Reference 32). When the marine propulsor is a waterjet, under some conditions the thrust deduction factor, $(1 - t)$ may be greater than unity, partly accounting for the surprisingly high propulsive coefficients for **waterjets**.

Current Design Issues for SES Resistance

The prediction of resistance for **SESs** has reached a fairly advanced stage of maturity and reliability.

Theoretical formulations for cushion wave-making drag are necessarily based on simplifications in order to handle the highly complex mathematics. In any case, the detailed information necessary for more realistic math modeling of an actual air cushion is simply not available in **numerical** form. Newman and Poole's method allows correction to be made for tow-tank width and depth effects but produces unrealistically high drag **peaks** at low speed. This problem is presently overcome by applying a theoretical wave steepness limitation.

It is always assumed that cushion wave-making drag is independent of sea state, and that the large increase of total drag with increased wave height is mainly a function of increased wetting and skin-friction resistance. If so, seal resistance, for instance, should scale with Reynolds number as has been found with the skirts of ACVs. This is an area of current investigation. Typically seal resistance of an SES, is obtained from model data by subtracting the sum of the other drag elements from the total drag of the model. Although seal drag is a small fraction of the total drag, much discussion and analysis has been devoted to this subject over the years without a final consensus being reached.

SES Powering Requirements

The power required for the lift and propulsion of an SES depends not only on the performance requirements but also on the choices made for subsystems and how successfully the designer has optimized their integration balanced against the demands of other requirements, not the least of which is cost. This task can best be handled by a whole-ship design synthesis model (Reference 25) which can quickly examine the cost impacts and merits of a very wide range of hull geometry and subsystem choices.

The range of powering requirements exhibited by existing SES including a few recent SES designs is illustrated in Figure 75 in terms of total-installed continuous power per unit full-load displacement versus Froude Number. The Froude Number here is based on overall *craft* length and speed in calm water. The SES in Figure 75 are compared with a corresponding set of data representing contemporary monohulls including some designed for very high speed. Data from the same craft are shown in Figures 76 through 78. Figure 76 is similar to Figure 75 but uses speed as the abscissa. Figure 77 uses the displacement Froude Number instead of Froude Number based on overall length. This was included to avoid biasing the results since monohulls generally have higher length-to-beam ratios than SES. The basic trend, however, is much the same as in Figure 75.

Figure 78 shows installed power per ton knot versus Froude Number. In this case, the continuous power was divided by the product of full-load displacement and the (continuous) calm-water speed. Again, the basic trend is unchanged. The SES is demonstrated to have a very significant powering advantage over the monohulls for operation at high speeds.

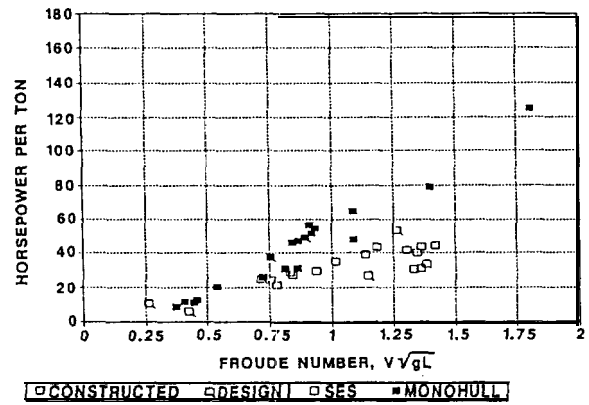

Figure 75. Installed Power/Full-Load Displacement Versus Froude Number

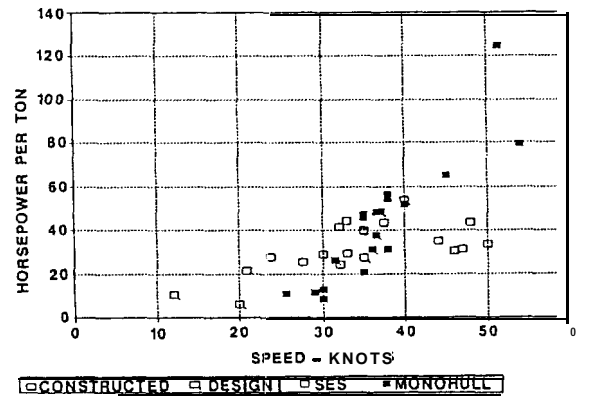

Figure 76. Installed Power/Full-Load Displacement Versus Speed

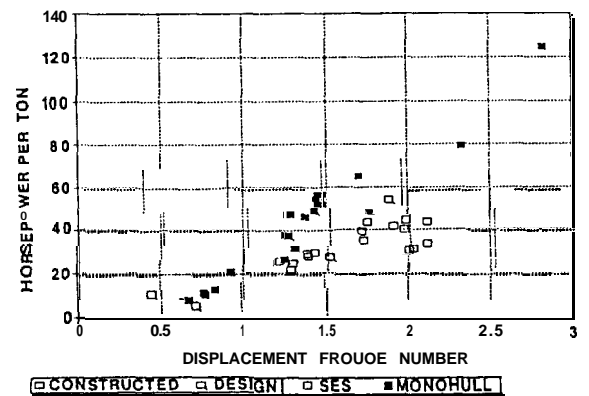

Figure 77. Installed Power/Full-Load Displacement Vs Displacement Froude No.

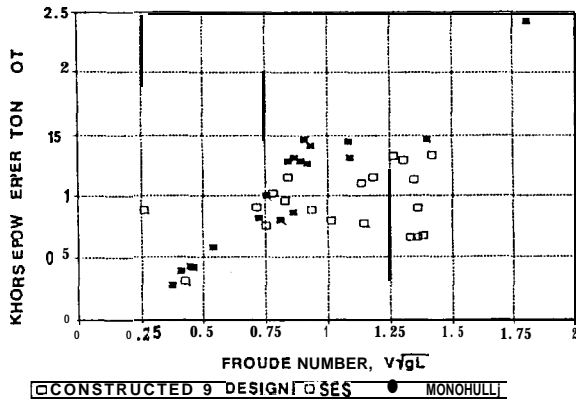

Figure 78. Installed Power/Full-Load Displacement/Speed Versus Froude Number

What is also clear from these data is that there is a fairly wide scatter in the points plotted for SES, particularly at the higher speeds, indicating the range of success that the various designers have been able to achieve for their particular set of requirements.

Subsystem Weights

During the early stage of a design the weights of the various subsystems can be approximated using trends from prior experience. However, if a whole-ship design synthesis model is available for the early design stage it is preferable that the weights be calculated from first principles for as many subsystems as possible. The weight of the structure of the hull, the seals, and fuel load are examples where this is clearly possible and was used, for example, in the model of Reference 25. In later stages of design, estimates can be more precise as a result of more detailed analysis and from the known weights of off-the-shelf systems and equipment.

Trends exhibited by the comparison of the subsystem weights of existing craft are useful, however, as a sanity check in early stage design. If used for design, they must be accompanied by fairly large margins to allow for uncertainties in design and construction. Weight margins can vary from subsystem to subsystem with the value depending upon how well they have been defined, or the margin can be applied as a single value to the lightship weight. Weight margins varying from 8% to 20% are typically used.

It is essential to use a consistent definition of the weights included in each subsystem group. In the

U.S. it is customary to use the I.J.S. Navy's Ship Work Breakdown Structure (SWBS). For SES, this system consists of:

- SWBS 100: Hull structure including end seals
- SWBS 200: Propulsion including lift system
- SWBS 300: Electrical systems
- SWBS 400: Command, Control and Communication and Navigation Systems (C³N)
- SWBS 500: Auxiliary Systems
- SWBS 600: Outfit and Furnishings
- SWBS 700: Armament.

The sum of these weight groups comprises the lightship weight.

These definitions are used for the weight trends discussed below for which the known weights of subsystems for a range of existing SES are plotted, generally, as a function of full-load displacement. Parameters, other than full-load displacement, are often more appropriate. These include hull volume for SWBS Group 100, installed power for SWBS Group 200 and total electrical load for SWBS Group 300.

Structure (SWBS 100)

The weights of the structure for a number of SES are shown in Figure 79 as a function of hull cubic number. The cubic number used here is the product of overall craft length and a cross-sectional area amidships formed by rectangles containing the two sidehulls and the main hull (including superstructure). No attempt has been made to distinguish between the choices of structural concept or types of material used in construction of the various craft represented in Figure 79. However, they are either constructed of welded or riveted marine-grade aluminum alloy or single-skin glass reinforced plastic (GRP). In comparison to this data, a weight savings of between 5 and 10% could be expected with the use of foam-core GRP. Figure 80 is similar to Figure 79 but, this time, full-load displacement is used as the abscissa, instead of cubic number. A mean line through the data would suggest that the average weight of the structure is approximately 36% of the full-load displacement with low and high extremes of 24% and 40%, respectively.

Lift and Propulsion (SWBS 200)

The weight of SWBS Group 200 for various SES is shown in Figure 81 versus full-load displacement. The SES represented have either diesels or gas

turbines, waterjets, or marine screws. With one exception they are fitted with centrifugal fans. A mean line through the data suggests that SWBS Group 200 is approximately 21% of the full-load displacement.

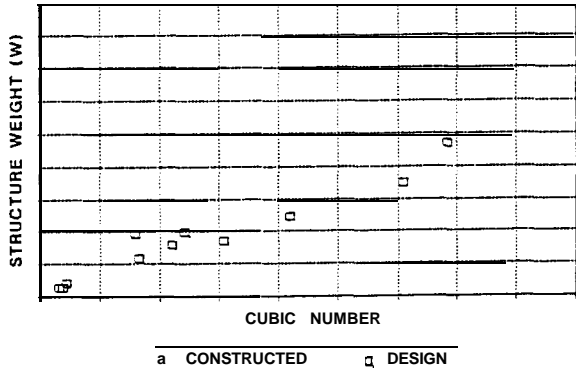

Figure 79. Weight of Structure Versus Structural Cubic Number

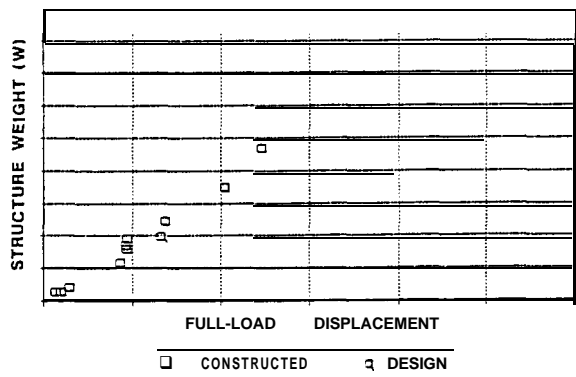

Figure 80. Weight of Structure Versus Full-Load Displacement

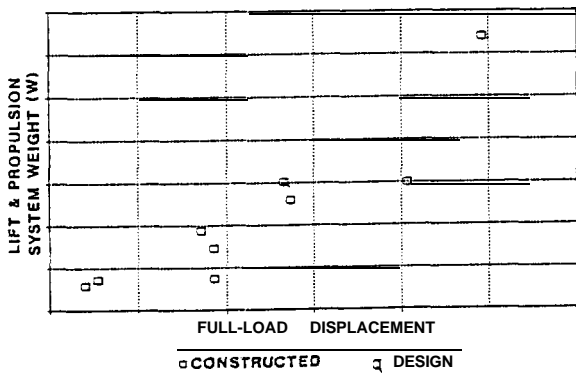

Figure 81. Weight of Lift and Propulsion System Versus Full-Load Displacement

Electric System (SWBS 300)

The weight of SWBS Group 300 shown in Figure 82 shows considerable scatter among the various SES represented, which include experimental craft, commercial ferries and paramilitary craft. Over this spectrum of applications it would appear that the weight of SWBS Group 300 could vary from as little as 0.6% to as high as 5.5% of the full-load displacement. Note that the weight of SWBS Group 300 (as well as Groups 400 through 700) would generally be expected to be more dependent upon operational role than would the weights of SWBS Groups 100 and 200.

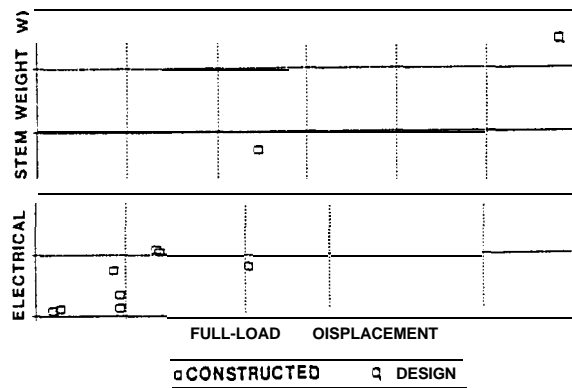

Figure 82. Weight of Electrical System Versus Full-Load Displacement

C³N (SWBS 400)

The weight of C³N systems are shown in Figure 83. Values vary from, approximately, 0.5% to 4% of full-load displacement, with the higher percentage applicable to military craft.

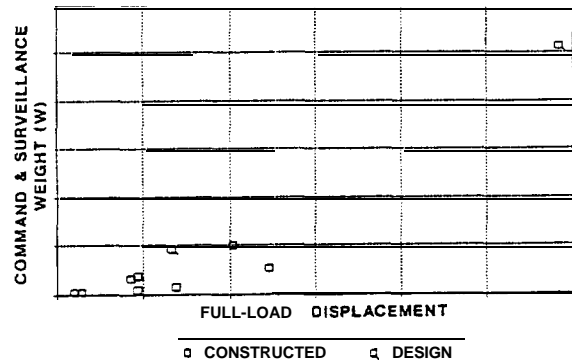

Figure 83. Weight of Command and Surveillance System Versus Full-Load Displacement

Auxiliary Systems (SWBS 500)

The weight of auxiliary systems are shown in Figure 84. Although there is significant scatter, there is a distinct trend with a mean of approximately 8.5% of full-load displacement.

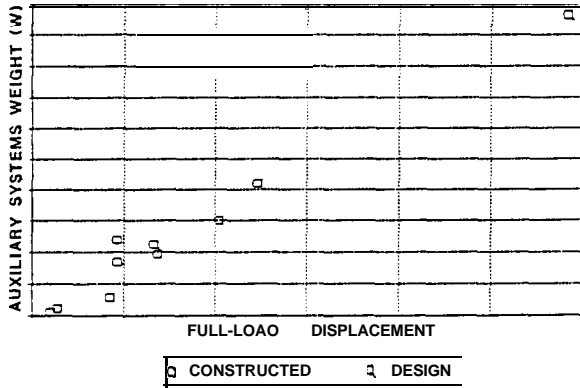

Figure 84. Weight of Auxiliary Systems Versus Full-Load Displacement

Outfit and Furnishings (SWBS 600)

The weight of this group is shown in Figure 85 and appears to be even more widely scattered than SWBS Group 400. The average is approximately 5% of full-load displacement with commercial ferries generally on the high side of the scatter.

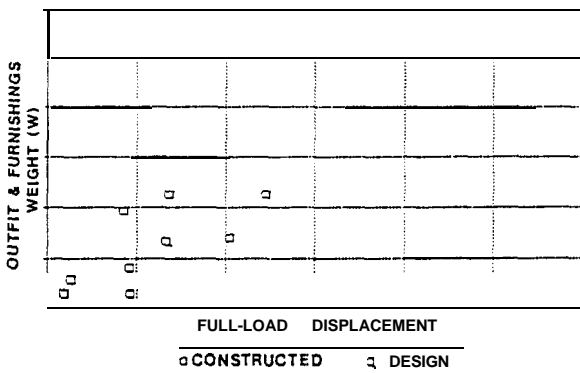

Figure 85. Weight of Outfit and Furnishings Versus Full-Load Displacement

Armament (SWBS 700)

This weight group, applicable only to military craft, was found to be extremely mission dependent and generally in the range of 2 to 7% of full-load displacement.

Disposable Load

The difference between the full-load displacement and the sum of the weights of SWBS Groups 100 through 700 and any margin is often referred to as the disposable load and is the sum of fuel load and payload. Typically, this weight can be from 15 to 30% of the full-load displacement depending upon the mix of requirements.

Seakeeping

Important aspects of SES seakeeping include:

- a. Ride comfort as determined by the magnitude and frequency of vertical, longitudinal and lateral accelerations at critical locations on the craft.
- b. The amplitude and period of motions in pitch, heave and roll (and in some cases yaw).
- c. The frequency of propulsor broaching.
- d. The frequency of shipping water on deck.
- e. Course-keeping.
- f. Structural loads including shock and vibration.
- g. Speed reduction.

All of these will vary with sea state, (wave height, modal period, heading), craft speed, craft heading, craft geometry, lift system setting and mass properties.

The importance of these measures of seakeeping will depend upon the intended role of the craft. High-speed passenger ferries operating in coastal waters are usually restricted by items a, c, e, f and g. For military weapon platforms, all categories are usually important. Since the provision for acceptable ride comfort is often the most challenging, the following focuses on this aspect of SES design and operation.

Ride Comfort

Ride comfort is an ongoing concern for all high-performance marine craft.

Passengers and crew can be exposed to bodily vibration which may cause motion sickness, fatigue, and reduced working efficiency. It is, therefore,

important that human tolerance to such vibrations be considered in the selection of design parameters which influence vehicle dynamic response.

Despite the fact that the relationship between man's comfort, working efficiency and vibration environment is very complex, a standard (or set of criteria) has been established (Reference 33) by the International Organization for Standardization (ISO) as a guide for the evaluation of human exposure to whole-body vibration.

The International Standard defines numerical values for limits and duration of exposure for vibrations transmitted to the human body in the frequency range 1 to 80 Hz. The standard states that it may be applied, within the specified frequency range, to periodic vibrations and to random or non-periodic vibrations with a distributed frequency spectrum. The limits are given for use according to three (3) generally recognizable criteria for preserving comfort, working efficiency, safety and health. The limits set according to these criteria are named, respectively as the "Reduced Comfort (RC) Boundary," "Fatigue-Decreased Proficiency (FDP) Boundary" and the "Exposure Limit" (EL). For example, when the primary concern is to maintain working efficiency of the crew in performing their various tasks the FDP Boundary would be used as the guiding limit, while in the design of passenger accommodation the RC Boundary should be considered.

The ISO standard provides guidelines to the limitations of vibrations that the operators or passengers, in a vehicle such as an SES, would experience in surge, sway and heave.

This ISO standard, however, does not extend below a frequency of about 1.0 Hz. Unfortunately, this region includes the frequencies for which wave-induced motions can be dominant. It is also within this range of frequencies where man is most prone to motion sickness. The appearance of such symptoms depends, however, on complicated individual factors not simply related to the intensity, frequency or duration of the motion. Although, so far, motion sickness has not been a particular problem with SES operations in rough seas, it is clear that the range of motion frequencies encountered are not adequately covered by existing ISO standards.

To remedy this situation it is customary to adopt a modification to the standard ISO curves based on the work of O'Hanlon and McCauley (Reference 34).

Ride Control

Continuing efforts are being made to improve the ride quality of SESs through better lift-fan characteristics (Reference 35) and the development of improved ride-control systems (RCSs), References 36, 37, 17 and 19.

These ride-control systems seek to maintain a constant cushion pressure thereby minimizing craft vertical accelerations and motions. This is accomplished by venting cushion air when cushion pressure rises, and increasing lift flow when cushion pressure falls. An RCS requires a control law, sensitive instrumentation and a responsive hydraulic system to adjust the vent vanes and/or fan inlet-guide vanes or other fan-flow-control devices.

The systems are most effective in dampening craft heave motion at high speed in low-to-moderate sea states, particularly when wave encounter frequency is close to the heave natural frequency of the craft. In high sea states, when the sidehulls support a substantial portion of the vehicle weight, and contribute more to inducing craft motion, current systems are not as effective, particularly when operating close to pitch resonance.

Ride-control systems (RCS) are available and have been used on many craft. The first RCS was developed by Aerojet General and used successfully on the SES-100A in 1972. Subsequent craft with RCSs have included the Bell SES-1 OOB, 1974; XR1 -D (1975), subsequently fitted with variable-flow fans; BH 110; SES 200; and others including the CIRRUS family of 105P, 115P and 120Ps which, apart from the SES 100A and 1008, used systems successfully developed by Maritime Dynamics Inc (MDI) in the United States (Reference 37).

KKrV in conjunction with SSPA in Sweden have also developed a similar ride-control system that was used successfully on the JETRIDER (Reference 17).

Other efforts to improve SES ride comfort have included the rudder-roll stabilization systems used by Hovermarine on their HM5 series of SES. This system could half the roll of the craft in rough beam seas. The stern-seal pressure-control studies by Clayton at the University College, London, (References 59, 60 and 61) and the general seakeeping studies and tests by Knupffer et. al., (Reference 19) are examples of recent efforts conducted to minimize SES pitch motions in heavy seas.

MDI has continued the development and demonstration of more effective RCSs. An advanced digital RCS involving "distributed" vent valves and a multi-input/multi-output controller has been installed on the SES 200 for evaluation in 1991.

Design for Seakeeping

It is extremely important that considerations of seakeeping be included in the earliest stages of design. Too often, designs have been developed without this consideration only to be faced with serious problems later that development in the towing tank or use of an RCS cannot necessarily solve.

It is important to start with a good knowledge of the area in which the SES is expected to operate. This knowledge must include a description of the energy-frequency spectrum of the waves, and their frequency of occurrence and direction relative to the intended route.

Foremost it is important to select a vehicle large enough and of the appropriate length and length-to-beam ratio. The size and geometry of the craft may be dictated by the size and geometry of the payload but can be dictated by seakeeping, particularly when avoiding pitch, or roll, resonance in high sea states for the operational area of interest.

Figure 68 (Reference 21), shown earlier, is an example in which seakeeping requirements have determined the minimum acceptable size of an SES.

Figure 68 was produced with the use of a whole-ship design synthesis computer model (Reference 25) from which a plot has been produced showing relative cost versus platform dimensions. Plots like Figure 68 can be used to determine the minimum cost solution for any set of requirements. Figure 68 presents a busy chart but shows how cost varies with changing length and beam for craft all designed to meet just one set of speed, payload and range requirements.

Overlaid on Figure 68, as broken lines, are two sets of curves of varying RMS vertical acceleration. There is one set for CG acceleration and another set for bow acceleration, all for operation at 35 knots while heading into a sea-state 3.

Craft which exceed the bow vertical acceleration limit (of 0.275 g rms) are below the lowest shaded area of the plot. None of the craft, however, exceed the CG vertical acceleration limit (of 0.15 g rms). A single

value, in each case, for an acceptable rms vertical acceleration at the bow and CG in head seas was selected here for convenience in early-stage design. These limiting values of rms accelerations can change depending upon operator's requirements.

Also shown are the freeboard limits for acceptable deck wetness which restrict the choice of platforms to those which are to the left of the shaded areas on the right-hand side of Figure 68. The freeboard limits used are based on the curves derived from Reference 21 developed by Savitsky and Koelbel for small monohulls and show the ratio of freeboard (at the forward perpendicular) to the length on the waterline plotted as a function of waterline length. The curve suitable for open ocean was adopted for this example and was applied to govern the minimum acceptable freeboard for SES operating hullborne.

The least-cost solution which satisfies these specific requirements is a craft having cushion dimensions of 98 ft by 39 ft, as shown on Figure 68.

Figure 86 shows all the least-cost solutions for the requirements stated on the figure. The solution taken from Figure 68 is shown at the bottom. Similar figures can be developed to describe the relationship between cost and any other set of requirements.

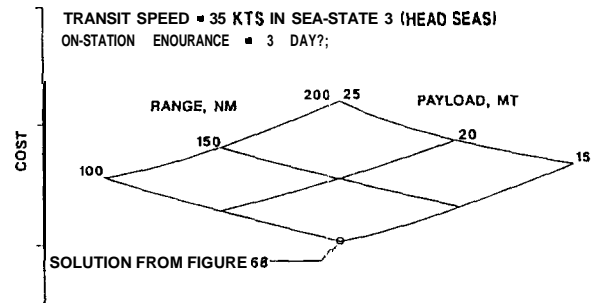

Figure 86. Cost Versus Range and Payload for Craft Designed for Acceptable Seakeeping in Sea-State 3

The results shown in Figures 68 and 86 were for operation in sea-state 3. Thus, all craft were designed with power to achieve 35 knots while heading into a sea-state 3 with acceptable ride quality.

However, for operators interested in a higher sea-state capability the effect on seakeeping of

operating these same craft in sea-state 4, at a lower speed of 25 knots, is shown in Figure 87. This is a speed that all the craft could achieve without increase in total power.

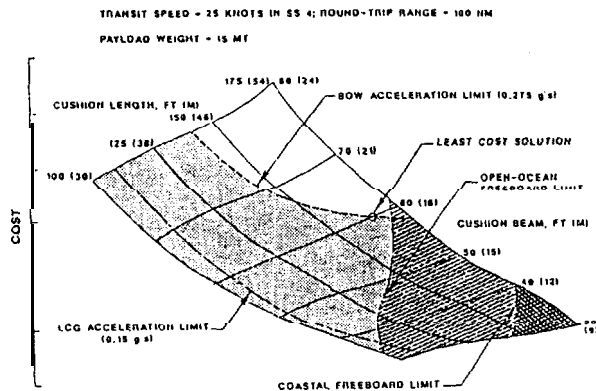

Figure 87. SES Design Selected on the Basis of Seakeeping

In this case, as shown in Figure 87, much larger craft are required to meet the requirements. Here the vertical acceleration at the bow is the controlling factor and we cannot select craft dimensions from within the shaded area of this figure.

The least-cost craft for sea-state 4 that meets the stated requirements listed at the top of this figure is, therefore, a craft with cushion dimensions of 164 ft by 59 ft as compared to 98 ft by 39 ft for sea-state 3. The corresponding cost had, in fact, doubled as a result of designing for sea-state 4 as compared to sea-state 3.

Stability

Stability Hullborne

When an SES is hullborne its stability in the intact and damaged condition is dominated by hydrostatics and can be determined and assessed using procedures and criteria which are similar to those used for conventional vessels. Predictions are most easily made using a modified version of the U.S. Navy's "Ship Hull Characteristics Program (SHCP)" or the program called "Stability of Any Arbitrary Form (STAFF)". The assessment of acceptable stability will depend on the size, gross registered tonnage and intended role of the vessel and can be governed by the classification societies such as the American Bureau of Shipping (ABS) and Det norske Veritas (DNV) and also by the International Maritime Or-

ganization's (IMO 's) regulations for dynamically supported craft, the US Coast Guard's (USCG's) requirements defined by the appropriate code of Federal Regulations and/or U.S. Navy's requirements for Advanced Naval Vehicles.

Stability On-Cushion

When an SES is underway at high speed the hydrodynamic forces acting on the sidehulls, the bow-and-stern seals, the appendages and the forces due to the waterjet inlet: and nozzle deflection, or rudder deflection, dominate the hydrostatic and aerodynamic forces. Estimates of these forces are fairly accurate if the hull parameters and vertical center-of-gravity/overall-beam ratio of the new SES design are within the range of known proven designs. Variation in hull parameters such as length/beam ratio, sidehull width/beam ratio, cushion depth/beam ratio, sidehull volume, etc.; seal geometry, fins, rudders, and fences; and propulsion parameters such as fully-submerged propellers, semi-submerged propellers and waterjets make each design unique. Towing tank stability tests of the final design are recommended to accurately predict SES stability on-cushion (References 38 through 41).

Pitch stability can be readily obtained by proper shaping of the sidehulls and bow seal as discussed earlier.

Roll stability at hover and at speed, at zero sideslip, is provided by the sidehull geometry and the ratio of vertical center-of-gravity to overall beam. Flexible bow and stern seals do not contribute much to roll stability. However, the cushion pressure acting about the roll center produces a destabilizing roll moment.

When an SES is in a turn, the centrifugal force acts at the VCG in a direction away from the center of the turn. In a steady turn, this force must be counteracted by sidehull hydrodynamic forces. These forces are a function of sidehull immersion determined by craft heave, pitch and roll and by local water sideslip angle. Proper shaping of the deadrise surface up to the chine will ensure that the planing force acts above the VCG and produces a restoring roll moment. However, hydrodynamic forces acting above the chine on the leading sidehull, and on the cushion side of the trailing sidehull, act below the VCG and produce a destabilizing roll moment.

Directional stability (yaw) is largely a function of craft attitude relative to the water surface and appendages

(fins, rudders, fences). The craft is usually designed to have a small, positive controls-fixed directional stability for the range of normal operating pitch attitudes. **Bow-down** trims from these attitudes can **lead** to directional instability requiring constant steering. However, at bow-up trims the craft can have too much directional stability and therefore poor maneuverability. Also, the craft is significantly more directionally stable when rolled out of the turn than when rolled in. SES designs with fins or rudders can also produce large changes in sideforce, roll and yaw moments at **sideslip** angles due to ventilation/cavitation effects that alter the lift coefficient. These cyclic variation in appendage forces can contribute to a "limit cycle oscillation" in pitch, roll and yaw (References 39 and 40). Therefore, by operating the craft at the proper pitch, attitude, appendages may not be required for a craft with **waterjet** propulsion.

Open sea radio-controlled SES model tests in the on-cushion mode have demonstrated (Reference 40) that, for the model tested, capsize in wind and waves occurred **at** a lower VCG than when maneuvering at maximum speed in calm water. In fact, capsizes in the latter condition only happened at very elevated **VCGs**. However, all models exhibited highly undesirable large amplitude roll/yaw oscillations in **calm-water** turns if the VCG was sufficiently high, such as to cause extreme difficulty in directional control. The ranges of VCG location for which capsizes occurred were well outside the values used in contemporary SES.

Thus, the Reference 40 tests identified two quite distinct areas for closer examination, synchronous rolling motion in beam seas and roll/yaw oscillations in high speed turns.

It has been found that an SES is most vulnerable to capsize if the rolling motion is excited near its resonant frequency, and if the roll energy imparted to the craft by the oncoming *wave cannot* be dissipated as the craft travels from trough to the next crest. Reference 40 discusses the complete critical cycle of an SES rolling in regular beam seas of resonant period, at a VCG just high enough to cause capsize.

The Reference-40 radio-controlled tests ascertained that forward speed did not affect beam-sea-capsize behavior significantly. Therefore, towing-tank tests were conducted with these models at zero speed (but free to sway) beam-on to artificially generated wind and steepness-limited waves to obtain the critical VCG. It was found that as the VCG of the model is raised, capsize first occurs in waves of approximately

resonant encounter frequency., when wave height exceeds about one third craft beam.

Also, certain models were tested with roll radius of gyration (K) varied substantially and with the transverse CG offset down-sea by 2% of beam. This offset can be due to improper loading of fuel, stores, cars, passengers and luggage. Full-scale large craft built to date have a roll **gyradius/beam** ratio (K/B) of about 0.3 while a majority of the models had a K/B ratio greater than 0.35. Limited model-test data indicate that if K/B is less than 0.35, then roll inertia has little effect on critical VCG.

Heave Stability

Heave stability can be **examined** by analyzing the cushion dynamics of the craft while hovering fully on-cushion in a stationary condition. It is not possible to predict full-scale cushion **behavior** based upon model test results. This is due to the problems presented in trying to scale cushion dynamics (References 42, 43 and 58). Because the compressibility of the cushion is governed by the gas laws, which depend upon absolute pressure rather than gauge pressure, it has been shown (Reference 42) that heave motion of an SES is more lightly damped than its corresponding model. This explains the tendency for SES to "cobblestone" at full-scale in relatively smooth seas where the predominant wave encounter frequency can excite the cushion natural frequency in heave. In rough seas the predominant encounter frequency is usually **too** low to excite heave at its resonant frequency unless the SES is extremely large (Reference 43).

Structural Design Loads

Considerable emphasis has been placed on the development of rational design loads during the design and testing of the U.S. Navy's **SES-100A**, **SES-1008** and **XR-ID** and during the very extensive design work carried out on the **3KSES** (References 44 and 45). One important development in the structural loads work for the 3KSES was the use of scale models to measure bending moments experimentally. Both rigid and structural-dynamic **grillage** models were developed and tested (Reference 45). A photograph of the **grillage** model is shown in Figure 88. It was by using these models that it was discovered that the loads experienced while operating SES at low speeds in the hullborne condition were usually higher than the loads measured at high speed on cushion.

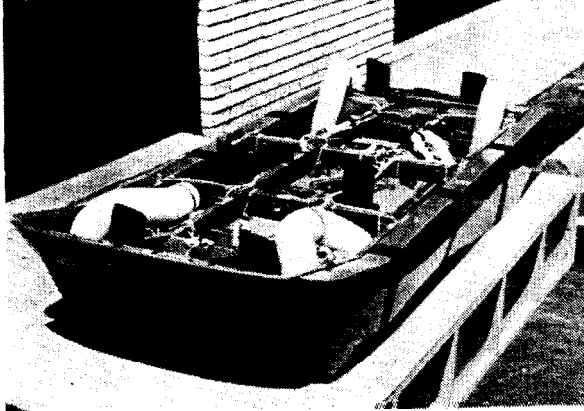

Figure 88.. Structural Dynamic Model of 3KSES

Structural loads for a new SES design are developed from a number of sources:

- The growing data base of loads used for earlier, successful designs.
- Loads measured experimentally during model tests and during full-scale trials. These loads are extrapolated by probabilistic methods to define maximum life-time loads.
- Loads specified by classification societies for high-speed craft such as those formulated by Det Norske Veritas (Reference 23), the British Civil Aeronautics Authority (Reference 46), and the American Bureau of Shipping (Reference 47, for example).
- Procedures developed by U.S. Navy activities such as NAVSEA Norfolk.

All of these sources provide information that can be used directly.

The loads of concern **are** the maximum expected lifetime values of, and fatigue-stress cycles related to the following quantities:

- Hog and sag longitudinal bending moments
- Transverse bending moments
- Vertical shear force
- Torsion about the longitudinal axis
- Hydrodynamic and hydrostatic pressures on all external surfaces

- inertia loads *on* all components, subsystems and cargo due to wave-induced accelerations
- Machinery-induced vibration.

ABS Structural Design Loads

Design loads specified by the American Bureau of Shipping (ABS) for SES are generally obtained from the ABS Proposed Guide for Building and Classing High-Speed Craft (Commercial, Patrol and Utility Craft) which is currently in publication (Reference 47). Design parameters necessary for obtaining design loads **are** to be submitted by the designer and include the following:

- Vessel Dimensions (L, L_{WL} , Beam, Draft, Molded Depth)
- Vessel Displacement
- Maximum Calm-Water Design Speed
- Vessel **Deadrise** at LCG (in degrees)
- Running Trim (in degrees)
- Vertical Acceleration at Both Wet-Deck and at Sidehulls
- Expected Operating Environment.

Wherever possible, submitted data for running trim and vertical accelerations are to be obtained from model tests.

The guidance **requirements** are augmented for bottom and cross structure loading by using, for example, bottom and cross structure design pressures obtained from Reference 48. These pressures are used in association with design allowable stresses for the materials as indicated in the ABS Proposed Guide. Other methods of obtaining design pressures may be accepted on a case by case basis.

Commercial Regulation and Classification

Fulfilling **all** regulatory, statutory and classification requirements for the safe design and operation of fast passenger craft is a challenge and must be considered early in the design process. The various statutes and regulations to be satisfied are numerous, subject to interpretation, often not conducive to the use of

light-weight systems and dependent upon the country in which (or to and from which) the craft will operate. In the United States the Coast Guard has jurisdiction over the certification of commercial craft via the general rules established by the applicable Code of Federal Regulations (CFR Title 46, for example). This code applies rules which vary depending upon the size (i.e., gross tonnage) and length of the craft and the number of passengers to be carried. Often design standards such as those defined by the American Bureau of Shipping (ABS) are referenced directly by the CFR. Until recently, neither the CFR or the ABS rules recognized the unique features of and construction methods for light-weight craft, but in 1989 ABS published, for review, their first set of applicable rules (Reference 47) which has now been issued in its final form.

Classification societies in other countries have also been very active in updating their rules for the classification of high-speed commercial craft spurred on by the rapid worldwide expansion of the fast-craft market. Most notable are the revised rules (distributed in draft form last year) to be published by Det norske Veritas (DnV) in Norway (Reference 23) and by Lloyd's Register (LR) in the UK, although UK craft are governed (at least until recently) by the rules set, in the 1960's (and periodically updated since), by the British Hovercraft Safety Requirements published by the British Civil Aviation Authority (CAA, Reference 46). Both the ABS and DnV rules follow the basic philosophy adopted initially by the British CAA and subsequently by the International Maritime Organization's (IMO's) "Code of Safety for Dynamically Supported Craft" (Resolution A 373 (X), Reference 22). This philosophy recognizes that high-speed ferries will be restricted to operate in well defined (coastal) areas where rescue services would be readily available. This restricts craft to operate within set limits such as speed and sea state.

Unlike the SOLAS 74 approach which calls for fully self-contained escape systems and onboard fire stations, the IMO Resolution A 373 (X) defines a set of more flexible requirements (and equivalences) . . . a move to ensure safety without stunting the fast-ferry industry's growth and ability to compete (Reference 49).

This recent flourish of activity by the classification societies is testimony to the recent and projected rapid expansion of the fast-ferry market. Readers interested in how these various rules are applied can refer to the respective codes or the summaries given in References 50, 51 and 52.

3.11 Hull Structure

SES hulls are being built from a variety of materials including welded marine-grade aluminum alloy, single skin or foam-cored Fiber-Reinforced Plastic (FRP), and high-strength steel. Each has its advantages and disadvantages and each yard tends to select that which they know best. Major considerations include material and construction cost, weight, strength, maintainability and fire resistance.

Aluminum Alloy

This has usually been the preferred choice in the U.S. It is readily available, its properties are well known, it can be easily formed and joined without expensive tooling, with careful design it can be reliably inspected and, more importantly, design standards and criteria are well established.

Welding is usually the preferred choice of construction. Although earlier regarded as being *more* of an art than a science, modern automated welding equipment has reached a very high level of development and is capable of economically welding much lighter gauge material, with lower thermal distortion than has hitherto been possible.

Because of the relatively low fatigue strength of welded aluminum, high-cycle fatigue of local structure is usually the greatest concern, avoidable preferably in the design stage by the avoidance of, or appropriate location of, stress concentrations, and by ensuring that the natural frequencies of structural components are not excited by predictable machinery vibrations.

The all-welded aluminum-alloy 250-ton AGNES 200 (Figure 2) is shown under construction in Figure 89. Construction began in May 1988 at CMN in Cherbourg and the ship was launched 26 months later, in July 1990. Construction proceeded initially by building four separate modules: one for the superstructure and one each for the forward, midships and aft sections of the ship.

These modules were eventually joined prior to the installation of machinery and other ship systems.

Figure 90 shows a view from behind the ship at the same stage of construction (May 1990) as in Figure 89. This view shows the unique shape of the sidehulls aft and the KaMeWa 71862 waterjet pumps in place.

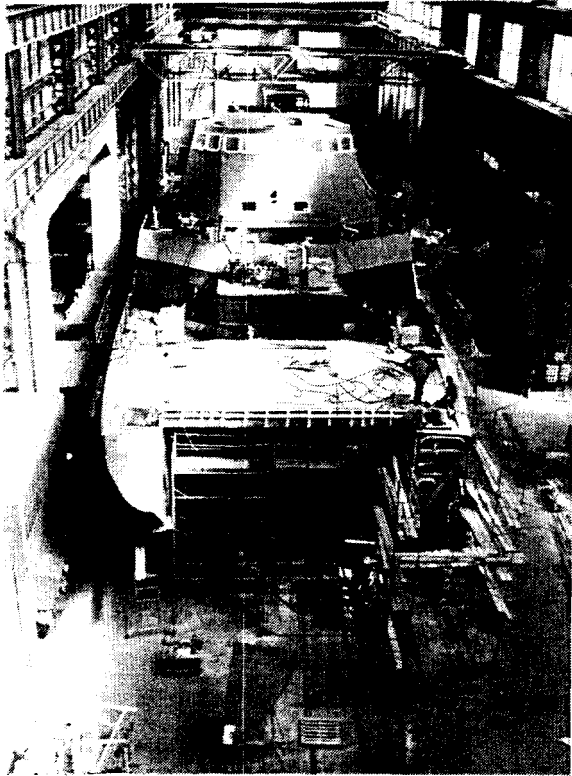

Figure 89. AGNES-200 Under Construction

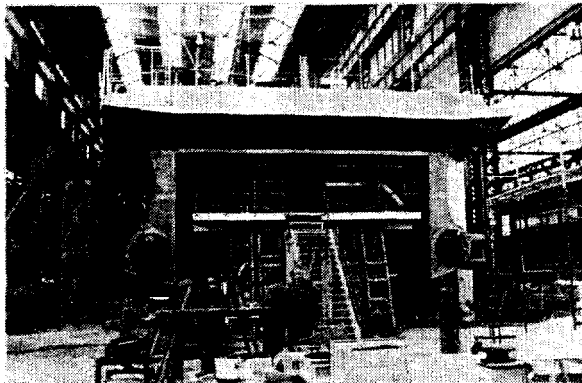

Figure 90. AGNES-200 From Astern (May 1990)

HM craft used woven and unidirectional glass rovings with polyester resin. Figures 93 through 96 show the various stages of construction of the HM 527. According to Reference 37, the structure of this craft could be built in less than four months while the cost of the molds and tooling amounted to about 15% of the total cost of the prototype. The molds were expected to be sufficiently durable to produce over 100 craft.

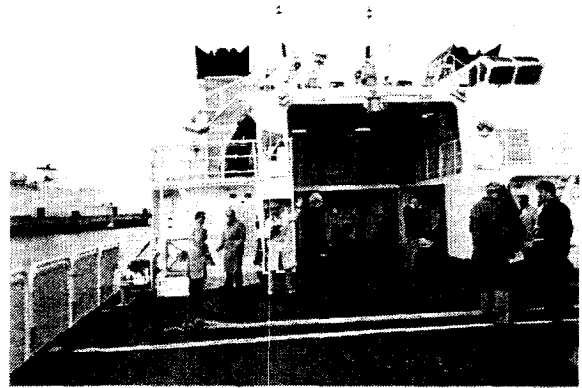

Figure 91. AGNES 200 Helicopter Flightdeck.



Figure 92. AGNES 200 Helicopter Hangar

Figures 91 and 92 show the completed superstructure including the helicopter hangar and flight deck.

Fiber-Reinforced Plastic (FRP)

The first SES ferry (the Denny D-2) was constructed of single-skin glass-fiber-reinforced plastic (GRP) as were the extensive production series of Hovermarine (HM) craft in the UK. Fiber-Reinforced Plastic (FRP) construction offers lightweight, durability, reparability, corrosion resistance, ease of construction (particularly of complex shapes) and reasonably low cost. The

Cored GRP was introduced by the U.S. Navy in 1955 (Reference 53). Over the seven years to 1962, 32 Navy GRP boats from 33 to 50 ft in length were constructed by the "core mold" method, a technique similar to that employed today in Norway and Sweden. Since the early 1960's the Royal Netherlands Navy has had many PVC-cored GRP craft constructed in lengths up to 77 ft. The 77-ft Pilot Boats, in particular, have seen nearly 30 years of extremely rough service. After many years operating off the Hook of Holland they were sold to India where they are still in operation.

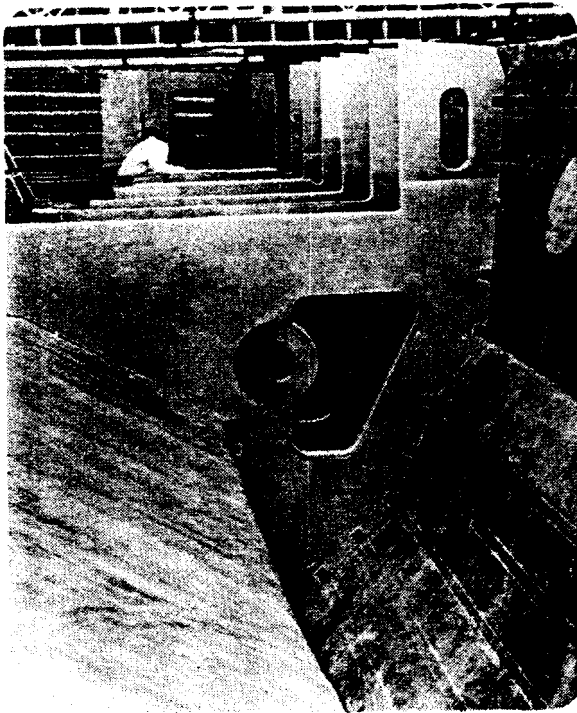

Figure 93. HM-527 FRP Interior Structure (UK)

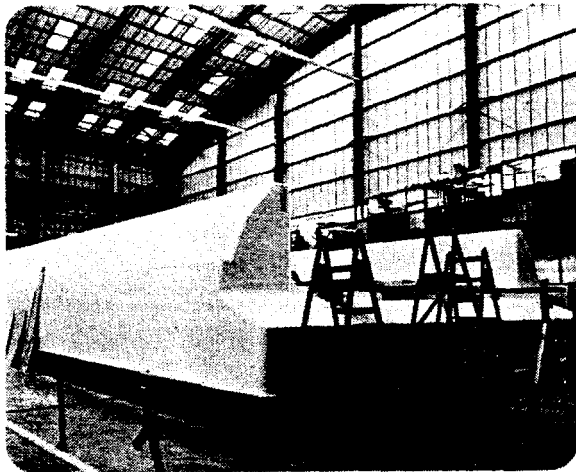

Figure 94. HM-527, FRP Hull Upside Down Viewed From Astern (UK)

Currently, the very successful series of craft designed by Cirrus and constructed by Brodrene Aa in Norway, the SES by Karlskronavarvet (KKrV) in Sweden (Figure 97, Reference 17) and the Blohm und Voss Corsair from Germany are examples of successful efforts to significantly reduce structural cost and weight using foam-cored structures.

Traditionally, glass-reinforced polyester is used for the skin, to sandwich a laid-up core of expanded cellular

PVC. With the trend toward *larger* SES the introduction of higher-modulus fibers (aramids or carbon) may be attractive to improve laminate stiffness.

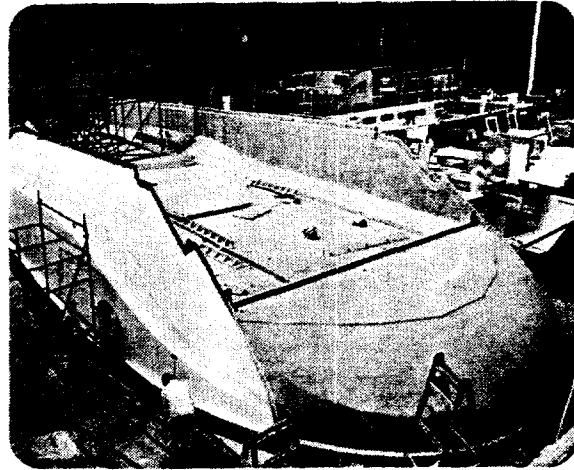

Figure 95. HM-527, FRP Hull Upside Down Viewed From Ahead (UK)

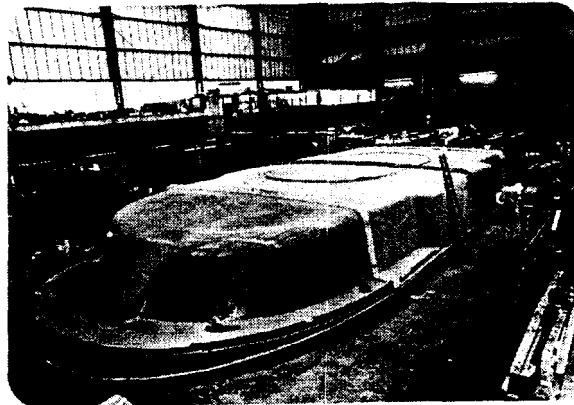

Figure 96. HM-527, FRP Superstructure (UK)

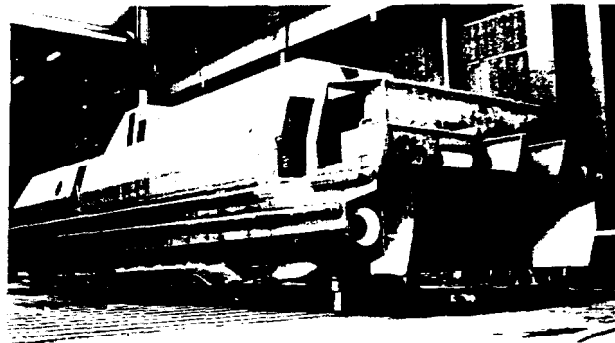

Figure 97. Norway, KKrV, Jetrider (The Complete Hull and Superstructure Built in Cored GRP-Sandwich)

Cored GRP structure also offers advantages in thermal and acoustic insulation. The Norwegian MCMs and the Swedish stealth Testrigg have emphasized the noise and vibration damping advantages along with IR reduction. In the case of the passenger ferries it is clear that cost savings played as much a role in selection of cored GRP as did weight savings.

Steel

China was the first to use steel for SES structures. The Italian shipyard, **Societa Escercizio Cantieri SpA** (SEC), now has the main hull of the world's largest SES (at 2000 ton) under construction in steel (Figure 1). **MTG's SES-700** (Figure 45) is also to be constructed of steel. High-tensile steel results in a heavier, more rugged structure, but is less expensive than aluminum alloy or FRP. It is also more fire resistant and has a higher fatigue strength than welded aluminum alloy.

As SES become larger, steel becomes more attractive since the need for minimum gauges for welding no longer presents a serious weight penalty. Also, the technology required for the design and construction/producibility of large steel structures is less of a technical risk.

Marine Propulsors

The problem of properly defining marine propulsor performance, particularly of waterjets, is relatively complicated. To reproduce **waterjet** propulsor performance maps generated by a manufacturer usually requires the selection of high values for component efficiencies such as inlet recovery, pump efficiency and nozzle efficiency, etc., unless account is taken of other factors such as hull influences. These influences include the nature and thickness of the boundary layer on the hull ahead of the inlet, changes to the hull pressure distribution due to the presence of the flowing inlet (Reference 54), changes to the hull flow field far ahead of the inlet, and factors associated with outflow from the air cushion and features of the **sidehull** shaping in way of the inlet.

KaMeWa, for example, has shown, by painstaking inlet model testing over many years that relatively small shaping changes to the inlet, particularly the inlet lip configuration, can exert a profound influence on the inlet performance. KaMeWa provides the inlet duct drawings to the shipyard for each application. They have not revealed the details of their inlet

configuration studies which led to their present designs.

KaMeWa is not alone in discovering anomalous **waterjet** inlet effects. During the waterjet-inlet model test program for the **2K/3KSES** much attention focused on inlet drag. It was found that, over a certain range of flow **parametrics**, the inlet drag coefficient appeared to be negative. Originally, this effect was thought to be due to either an instrumentation error or an accounting error. It is now believed that it may have been due, in part at least, to the hull effects postulated and investigated by KaMeWa.

Another aspect of the problem concerns the comparison with marine propeller propulsion on similar hulls. A strict comparison of propulsor performance in the two cases is **complicated** due to the influence of the appendages (shaft, **shaft** brackets, rudders) in the case of propeller propulsion, which are no longer present when waterjets are installed. It may well be that the propulsive coefficients claimed for propellers are too high due to the difficulties of properly accounting for all the appendage and wake effects. The result would be that a **waterjet** giving the same ship performance would be credited with a comparable propulsive coefficient. To verify such propulsive coefficients analytically necessitates invocation of negative inlet drag and/or hull lift effects which are otherwise difficult to **quantify**.

Air Ingestion by Waterjets

An important aspect of **waterjet** propulsion for SES concerns the phenomenon of air ingestion by the **waterjet** inlets.

Inevitably, the water approaching a **waterjet** inlet contains air bubbles. The mixture of water and air bubbles may arise from air entrainment at the forefoot, which is swept back to the inlets in the wake (boundary layer). Normally, the pump is very tolerant of this type of air/water mixture and there is minimal effect on thrust performance. However, entrainment of air exiting from the **cushion** under the sidehulls of an SES can affect pump performance. When this occurs, the usual symptoms are surging of the engine speed due to sudden loss of resisting torque when air is gulped by the inlet. In severe cases, this **over-speed** can cause the engine governor to shut down the engine. Obviously, 'the effect is likely to be more severe in waves than in Calm seas.

Steps which can be taken to minimize inlet broaching (gulping of air), and other forms of air ingestion include careful design of the sidehull ahead of the inlet (Figure 98), choice of inlet (sidehull) submergence and sometimes the provision of inboard fences to exclude cushion air, and outboard fences to minimize air ingestion directly from the atmosphere.

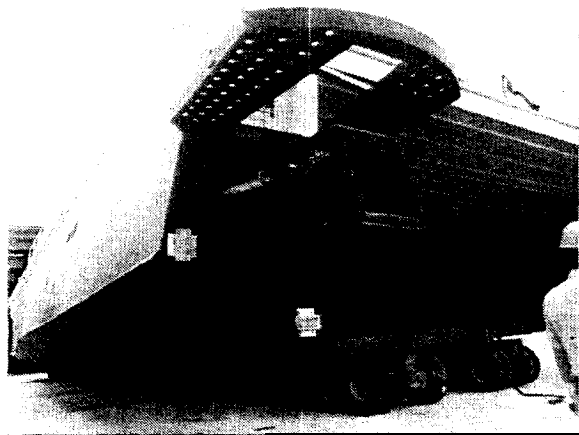

Figure 98. SES-200 New Waterjet Installation

Cavitation Limits of Waterjets

Waterjet propulsors designed for high speed cannot normally operate at full power at low ship speed due to cavitation in the impeller. A measure of the limit of cavitation-free operation of a pump is the suction specific speed:

$$N_{ss} = NQ^{1/2}/NPSH^{3/4}$$

N_{ss} = suction specific speed (a quasi-dimensionless number)

N = pump speed, rpm

Q = pump flow rate, gpm (by convention)

$NPSH$ = net positive suction head, ft.

With the above units, a mixed-flow pump without an inducer, such as the KaMeWa pump, would not be expected to operate much above a suction specific speed of 10,000. Inducer pumps such as the 2K/3KSES pumps can operate at full power with suction specific speeds up to 30,000.

KaMeWa, for example, provides guidance on the operation of its pumps in the form of limit lines on the

pump map (thrust versus ship speed for various power levels). These limit lines which divide the map into zones I, II and III, are similar to, but not coincident with, lines of constant suction specific speed, and are based on experience. Operation in Zone I is unlimited with regard to ship speed and pump power (rpm). Operation in Zone II is for rough-water operation. Sustained operation is permitted and will not noticeably affect pump performance, or life, but will not be cavitation-free. Operation in Zone III is for emergency use only and will be marked by reduced torque, severe cavitation, cavitation damage reducing pump life, vibration.

Part of the pump selection process is to superimpose the ship-resistance curves for various sea states on the pump map to see under what conditions operation in Zones II and III may occur. A speed-sea state envelope can be generated for each ship displacement of interest, limiting operation to Zone I, and to Zone I and II, for instance. Of particular interest, is hump transition in rough seas. If the hump is pronounced (depending on the length-to-beam ratio of the ship) hump transition with adequate thrust margin may necessitate intrusion into Zone II. Since the condition is transitory this is of no consequence. Use of Zone III for this purpose might be questionable, however.

Pump Performance Optimization

Some variation of the pump thrust curves is possible before or after pump installation, by choice of nozzle diameter within the normal range of nozzle ratio provided by the pump manufacturer. A larger nozzle will provide higher low-speed thrust with a steeper fall-off with speed and possibly a lower ship maximum calm-water speed. The final choice of nozzle size is a refinement in the detailed-design phase.

Marine Propellers

Marine propellers have been used on many SES including the UK HM-Series of craft, the U.S. Coast Guard WSES-Patrol Craft, the SES200 and the world's fastest ship, the SES1 OOB. Propellers may be of conventional high-speed subcavitating design, e.g. Gawn Burrill types, or of partially submerged, full ventilated supercavitating design as on the SES100(B) (Figure 99) and Corsair (Figure 100). A detailed account of propeller theory and matching to SES requirements can be found in Reference 32.

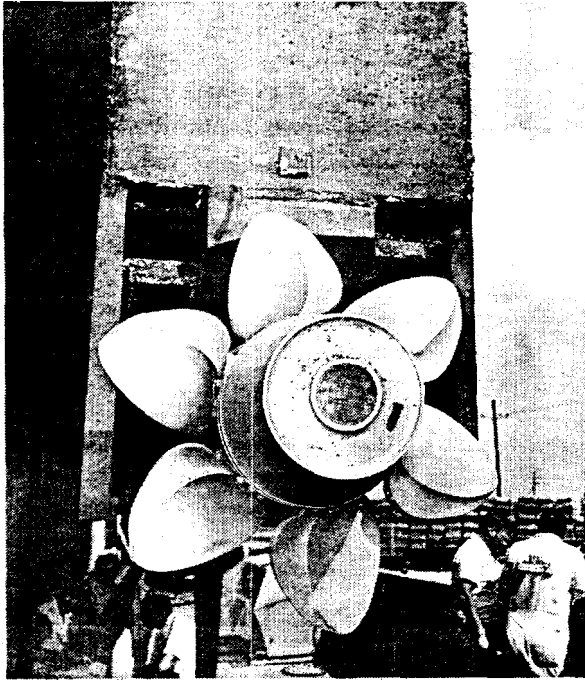

Figure 99. SES-100B Surface Piercing Propeller

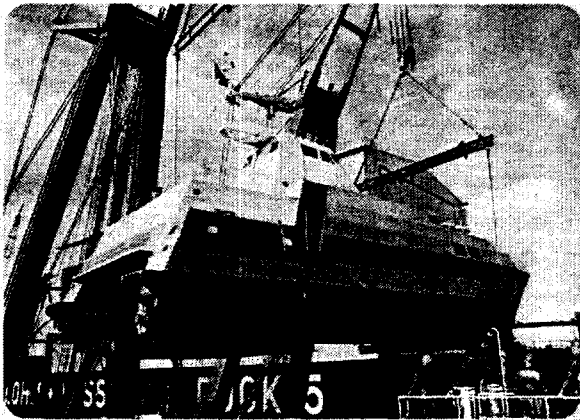

Figure 100. Blohm und Voss Corsair - Surface Piercing Props

For moderate speeds, waterjets have been preferred to propellers for recent SES because they allow operation in shallower water, have minimum appendage drag and are more easily matched to diesel engines. However, for very high speeds partially submerged propellers continue to be attractive. Generally a propeller installation will be lighter and the effective disc area allows for a high potential propulsive coefficient. Careful detail design of the propeller installation may allow a high overall propulsive efficiency to be released.

Prime Mover Characteristics

The characteristics of prime movers must be considered along with the performance of the propulsor. It is necessary to ensure that the engine has adequate torque for the propulsor and engine speeds considered. Matching of a diesel engine to a **waterjet** pump and choice of gear ratio for the transmission, is much simpler than for a propeller case. This is because the speed of the pump is almost constant for a given power over a wide range of ship speed. Never-the-less, engine-pump matching is just as important an aspect of the design of the propulsion system as is engine-propeller matching.

Propulsion System Installation

Other aspects of the propulsion system design which must be considered include propulsor installation, gearbox and engine **foundations** in the sidehulls and the necessity to ensure that there is adequate space around the machinery for operation and maintenance. To minimize noise and **vibration** the diesel engines should be **shock-mounted**. This will require the provision of suitable flexible couplings, and shafts.

Propulsion-System Performance

The prediction of the performance of the propulsion *system* is handled best by a mathematical model of the entire propulsion system. Such a model is particularly desirable if **an** integrated lift and propulsion system is to be used.

The propulsion system model combines the characteristics of the propulsor, transmission system, prime mover and any auxiliaries driven by the propulsion system engines.

THE FUTURE: SES POTENTIAL

In considering the future of SES it is useful to distinguish between those applications which are essentially profit driven (transport of people, vehicles and freight) and those which are essentially military, or non-transport, with missions where different measures of cost effectiveness are applied. For the purposes of this discussion the categories of transport, military and "other" have been chosen.

The beginning of the paper narrated the history of SES, its current **applications** and on-going development initiatives. With **the** exception of the Soviet Dergach, the Norwegian **MCMs** and the three U.S.

Coast Guard Sea Bird class SES, the military applications are still on paper.

TRANSPORT

SES have proven to be commercially competitive in the business of moving people from place to place (ferry service). Several hundred Hovermarine and Soviet SES operate at speeds below 35 knots, generally in sheltered waters where higher sea states are not routinely encountered. The new generation of SES people ferries, typified by the Cirrus **120P**, operate at speeds of 45 knots with hull configurations and/or ride-control systems that allow operation on more open-water routes.

Competition

SES are competing with planing craft, fast catamarans, wave piercers, hydrofoils (with fully-submerged or surface-piercing foil systems) and **ACVs** as well as the slower conventional ferries. More recently the FBM Fast Displacement Catamaran (SWATH), with a 30-knot-plus capability, has entered service from the island of Madeira. There appears to be considerable semantic confusion, in the minds of potential operators and builders, regarding distinctions between the various catamarans, SWATH and SES designs.

The essential parameters of a successful operation are cost, comfort and speed. "Convenience" may also be considered as a factor in the sense that amphibious **ACVs** may more effectively access shore connections and the increased draft of hydrofoils and SWATH may restrict operation in shallow waters. Generally, increased speed and/or comfort will increase the cost per passenger mile. In most applications, comfort tends to be more important than speed. The majority of current ferry routes are two hours or less in duration and are associated with traffic and queuing delays on either end which diminish the importance of small time savings. Given a choice, few passengers will return, however, after a bout of seasickness or the discomfort of a noisy cramped passage with an inability to move about the cabin. There are a number of quantitative measures (rms acceleration, roll period, etc.) which are applied to define acceptable motions but true measures of passenger satisfaction are elusive and, in the final analysis, only ridership and profit balance will determine the success of an operation.

The economic success of the new generation of 45-knot ferries is best evidenced by the number of

Cirrus **120Ps** delivered by Brodrene **Aa**. The eleventh, the Nissho, for Japan's Yasuda **Ocean Cruise Line**, has just completed builder's trials. Brodrene **Aa** is currently building the larger UT904 luxury SES in partnership with the Ulstein Group. Designs for similar craft have been developed by Royal Schelde, **Hovermarine** International and Fincantieri. The **120Ps** are operating on many routes worldwide, predominantly in Norway & the Mediterranean.

Car Ferries

The success of the people-carrying SES has led, logically, to the current wave of SES car-ferry initiatives described earlier. Potential routes around the world include the English Channel, the Mediterranean, the North Sea, Scandinavia and New Zealand. Competition **already** includes the operational **300-ton** SRN-4 **ACVs** and the 74-meter wave-piercer, Hoverspeed Great Britain (Sea Cat). SWATH car-ferry designs with speeds over 30 knots have been developed.

At this writing it appears that the Italian SEC-774 will be the first operational SES car ferry (1992) - with the others to follow.

Studies, including model tests, of a **perishable-freight-carrying** SES, of over 1000 tons, have been completed in Norway. This project is believed to be dormant at this time.

A consortium of seven Japanese shipyards is developing the design of a 50-knot **"Techno-Superliner,"** with an SES version as a principal candidate.

MILITARY

Coastal patrol (Coast Guard) missions are considered here to be military.

A significant military potential for SES has long been envisioned, as witnessed by U.S. expenditures of over \$400 million on the **3KSES** program which was closed out in 1979. The U.S. Navy's SES 200 has conducted **at-sea** trials with the Sea Vulcan and Hellfire weapon systems. The **SES-100B** successfully launched a surface-to-air missile. The NATO **SWG/6** studies, addressing ASW, MCM and Patrol missions, are discussed in Reference 21. **Many** U.S. Navy **design** studies have been conducted under the NAVSEA CONFORM and other programs addressing missions ranging from MCM and Escorts to Air-Capable

Cruisers and **Sealift**. The French AGNES 200, currently undergoing Navy trials, is intended to prove the concept of an air-capable ASW Corvette. The German SES 700, although by mission a test platform, would assess the suitability of SES for a Corvette or Frigate. The Spanish BES-50 program projects a **350-ton** patrol craft. The Blohm und Voss Corsair is being fitted with a gun module for military demonstrations and the company has developed a series of 43-meter military derivatives of this craft. Military derivatives of at least two of the SES car ferries have also been proposed. The Norwegian **Nortest, 220-ton**, Fast-Attack Craft initiative appears to be close to implementation.

Hardware

Today there are four operational "military" SES; the Soviet **Navy's 650-ton** Dergach, designated "guided-missile patrol combatant, air-cushioned," and the three U.S. Coast Guard Sea Bird class SES (140 tons). Construction is underway on the Norwegian Navy's nine-ship SES MCM class (350 tons). The French AGNES 200 and the U.S. re-engined SES 200 (both about 250 tons) are currently undergoing further test and evaluation focused on military missions.

Advantages of SES

Speed, which could exceed 60 knots but more practically would be in the 40 to 55 knot range, is the most obvious military advantage of the SES. With careful design and installation of state-of-the-art ride-control systems, SES offers significant **seakeeping** improvements over equivalent monohulls. There are other advantages, depending on the mission. For the MCM, shock attenuation is most important. In the case of the U.S. Coast Guard SES, which have operational speeds only a little over 30 knots, platform stability during long hours of loiter on drug-interdiction patrols have made these craft the most popular cutters in the fleet from a habitability standpoint (Reference 13). The twin-hull configuration and shallow draft introduce survivability/vulnerability benefits. SES deck area is particularly generous, as is enclosed volume, since SES designs are generally volume and not weight-driven. Excess volume is desirable where modular concepts are considered.

MCM

The SES concept was selected for the Norwegian MCM program as the result of a comprehensive analysis of SES, conventional and catamaran

alternatives. A key parameter in their analysis was hull material. The **MCMV** is built of cored GRP, as are all the Cirrus designs and three Karlskronavarvet (**KKrV**) designed SES. Norwegian analysis and shock tests of the Harpoon SES, and of a full-scale midship section of the Norwegian MCMV, have shown very significant shock attenuation for the SES on cushion. Shock tests conducted by Germany on the SES 200 showed similar results. The current NATO **SWG/6** studies are considering SES in competition with **ACVs**, SWATH, catamarans and conventional monohulls for the MCM mission. Several of the NATO nations are most attentive to the Norwegian SES MCMV development. U.S. interest in SES as an MCM platform was derailed by the demise of the MSH program in the mid eighties. The U.S. is, however, developing the SES MCMV design as part of the current NATO **SWG/6** studies.

ASW

The U.S. 3KSES program produced a contract design for a frigate with ASW capability and a projected maximum speed of over 80 knots. The NATO ASW studies produced conceptual designs of four air-capable SES ASW Corvettes (by the U.S., UK, France and Spain) which were designed to use sprint-search tactics. These designs had full-load displacements between 1200 and 2000 tons. The French AGNES 200 is **intended** as proof of concept for a **1250-ton** SES Corvette (EOLES). The German SES 700 design would have applicability to larger ASW escorts. In addition, several SES ASW variant designs were developed under the NAVSEA CONFORM program. The **650-ton** Soviet Dergach is apparently outfitted principally for air and surface defense.

Clearly, SES offer speed and survivability advantages for the ASW mission. The principal obstacle to developing an ASW SES at this time is simply size (displacement). To achieve acceptable ASW capability a major increment in displacement over the existing SES (**260-ton** in the U.S. and France, **650-tons** in the USSR) is required. The NATO **SWG/6** studies by the U.S. indicated that, for minimum acceptable ASW capability, an SES of at least 2000 tons (constructed of steel) would be required. The French **EOLES**, to be constructed of aluminum alloy, is close to 1250 tons.

A realistic expectation for an ASW SES would be either the French EOLES or a military derivative of one of the Italian car ferries. The Italian SEC-774

now under construction in steel, for example, has a length of 302 ft, and a full-load displacement of over 2000 tons. This ship is scheduled to be launched in 1992.

Patrol

Following a period of non-SES-related technical difficulties, the U.S. Coast Guard SES have emerged as three of the most effective cutters in the fleet (Reference 13). At this time, however, all near-term cutter replacements are expected to be conventional designs. The AGNES 200 and the Blohm und Voss Corsair are both being marketed in military variants. The Spanish BES-50 program is directed to a **350-ton** patrol craft with a **16-meter** manned model currently in evaluation. The **Nortest** initiative is particularly noteworthy. This Fast-Attack Craft promises speeds of 60 knots with an impressive armament suit. The current NATO **SWG/6** studies include SES designs for Harbor/Coastal Patrol (Figure 44), Enforcement of Laws and Treaties (**ELT**), Fast Surface-Combatant and MCM missions.

As the U.S. reevaluates the Navy's mission in the changing world arenas it is likely that the threat of a third-world conflict in areas like the Caribbean and the Persian Gulf will dictate new requirements for more expendable resources.

The risks associated with development of an effective SES patrol/attack capability, particularly as feedback on the car ferries materializes, should be most acceptable.

Sealift

The sealift issue has been very much in the news with Desert Shield and Desert Storm. The U. S. Navy's fast **sealift** ships have shuttled to and from the Gulf at **30-plus** knots. High-speed is surely a desirable feature. Several studies have been conducted of SES **sealift** ships of over 20,000 tons, or more, with speeds exceeding 40 knots in calm water. Definition of these ships is still very soft and the associated technical risks are considerable. The step from 260 tons is two orders of magnitude. At some point in the 21st century such ships could provide a feasible and cost effective option. The Japanese studies discussed earlier suggest that, as with SWATH, the Japanese may show us the way in large SES.

OTHER

The Bell-Halter 110s have been effectively used as offshore support craft for the oil industry. They offer good speed and seakeeping, a stable platform and large deck areas.

The City of Takoma in Washington state has, for some years, operated two Hovermarine SES fireboats. The City of New York is acquiring two similar craft.

The SES attributes of high-speed, good seakeeping, good platform stability, large **deck** area and shallow draft are attractive for numerous survey, supply and **workboat** applications.

CONCLUSIONS

The following conclusions are supported by this paper:

1. After 30 years of development and application, SES technology, as applied to small craft, is mature (state-of-the-art).
2. Associated design analysis, performance prediction and model--testing techniques are credible and reasonably well documented.
3. Hardware feasibility to 250 tons is established (650 tons in the case of the Soviet Dergach).
4. Potential advantages of SES are improved:
 - Speed
 - Seakeeping
 - Platform Stability
 - Deck Area
 - Enclosed Volume
 - Shock Attenuation
 - **Helo** Support.
5. Although variants and hybrids have been successfully demonstrated, a least-risk **hullform** has been established. A very consistent pattern for the selection of seals, lift systems, ride control and propulsors **has** emerged.
6. The designs of the several proposed car ferries reflect a consistency logically deriving from conclusion no. 5. Hull material is the principal variant.

7. The feasibility of steel, aluminum and single skin or cored GRP SES construction has been demonstrated.
8. National practices, economics, component manufacture and the rules of local regulatory agencies strongly influence the selection of craft materials and components.
9. The commercial viability of passenger ferries to 150 tons full-load, operating at block speeds over 40 knots, has been demonstrated.
10. The current emergence of SES car-ferry initiatives in six nations reflects a considerable confidence in the technical and economic viability of the SES concept to over 2000 tons.
11. Similarly, the appearance of the Dergach, the operation of the USCG Sea Bird class, and the development of the Norwegian **Nortest** FAC and Navy **MCMs** establish SES **as** a concept that must at least be considered for Patrol and MCM missions.
12. Many studies and designs notwithstanding, the feasibility of large (over 2000 tons) SES has not yet been credibly established. This is, realistically, dependent upon the evaluation of hardware at intermediate displacements. SES of intermediate displacements are, however, being built, or are under development in other countries by commercial concerns and by government programs.

RECOMMENDATIONS

Where do we in the U.S. maritime community go from here with SES? The design and construction capability for SES is in place in the U.S. Much of the technology was developed here. Other nations have developed the applications. The European experience is establishing the competitive viability of SES ferries, at least in their market. The military potential has been recognized and is being implemented in Norway, France, Germany, Italy, Spain and the USSR. Perhaps it is not too late for us in the U.S. to realize the economic and military potential of this technology we helped to introduce.

The following suggestions are categorized as: SES Generic, Transport, Military and Other.

SES Generic

It may be argued that., after committing major resources to the **3KSES** program, the SES community proceeded to oversell the concept for Naval missions ranging from ASW Frigates to Air Capable Cruisers and, most recently, **20,000-ton sealift** ships. The SES concepts' credibility has suffered accordingly. The problem has been that all the SES R&D investments were directed to Navy blue-water missions which did not include anything smaller than a Frigate. The Coast Guard, however, has most effectively utilized the military version of the state-of-the-art Bell-Halter **140-ton SES**.

The lesson suggested here is simply; "walk before you run". Risk must be commensurate with potential gain. Historically, advanced vehicles have only been developed, or been successful, under these terms.

1. In proposing applications, military or commercial, risks must be realistically assessed. State-of-the-art today, in the U.S., is 250 tons.
2. Based on world experience today, proposing current development of an SES, military or commercial, of 2000 tons full-load or less would be reasonable • if the design and all components are essentially state-of-the-art and the potential benefits, economic or military, justify the risk associated with simply increasing scale (and cost).
3. **SES** experiences must be credibly documented and translated into design and regulatory standards and methodology. The SNAME SD-5 Panel (Advanced Vehicles) is currently developing a T&R Bulletin for SES design. ABS and U.S. Coast Guard rules have been modified for commercial SES. Navy standards for building a **2000-ton** SES do not exist.
4. Foreign experience, particularly with the current and developing high-speed ferries and military craft, must be carefully observed and documented.

Transport

U.S. ferry operations, as long **as** they include two U.S. ports, are currently subject to the Jones Act which requires U.S. construction of the ferries. Given a route, an operator and financial backing, there are many U.S. yards well qualified to construct an SES

ferry. A design is required. Licensing of a U.S. yard for an "off-the-shelf" foreign SES ferry is one alternative. The other is to utilize the existing U.S. design capability to develop a state-of-the-art ferry specifically for U.S. shipyards, regulatory agencies and operating conditions.

The UMTA study (Reference 50), completed in 1984, was an in-depth assessment of the potential of high-speed waterborne passenger service for U.S. routes. Economics and technology have evolved in seven years but this seven-volume study offers valuable guidance for any, and all, of the participants in a present day high-speed ferry venture. Twenty-four foreign hydrofoil, SES, ACV and fast catamaran operations in Scandinavia, the Mediterranean, the Far East and South America were examined. It was concluded that these services were successful under the following conditions:

- a. Adequate numbers of passengers had a history of using public transportation and had limited access to automobiles.
- b. Competitive, reliable, high-speed ferries were readily available.
- c. Experienced operators existed with financial backing and management experience.
- d. Water transport had significant advantages over competing modes of transportation (road, rail and air).

In 1984, the most consistent detriment to successful operations was the prevalence of adverse **sea states**.

Ten potential U.S. routes were studied with the conclusion that several were feasible. A potential for 24 ferries was identified, which, in 1984, translated to a \$130 million market for U.S. shipyards.

Twenty examples of U.S. operations of high-speed ferries, largely unsuccessful, between 1962 and 1984 were examined. Several "facts" emerged from this phase of the study:

- a. A one-vehicle operation without back-up cannot succeed.
- b. Developmental vehicles are not suitable for a link in a transportation system.

- c. The financial manager must not be subordinate to the technical manager (developer).
- d. Repair and maintenance support must be adequate.
- e. Financial planning and support of the operation is vital.
- f. Competent market analysis is a prerequisite to any operation.
- g. Political considerations, particularly with respect to competing systems, are **critical**.
- h. The fast ferry must be an effective link in a transportation system, i.e., effective connections on both ends are necessary.
- i. The operation must be effectively promoted (advertised).

The issue of public (possibly subsidized) versus private ventures is **also** a consideration.

The bottom line of all this "gloom and doom" is simply that there must be a genuine need for the service and it must be economically competitive, reliable and attractive to the rider. This requires careful planning and adequate financial backing. The opportunities clearly exist.

Military

Patrol/Attack

The U.S. Coast Guard has already implemented an effective cutter role for SES in the **140-ton** size. SES could be a competitor for other cutter replacements but this is not highly probable in the near term. With respect to Navy requirements; aside from Foreign Military Sales (FMS), the only recent requirement for Navy craft in the 100 to **300-ton** range has been the PBC where requirements called for a **Non-Developmental Item (NDI)** resulting in procurement of conventional craft. Reassessment of Navy requirements in the light of **changing** world conditions could result in requirements for larger, faster and more capable patrol craft for which SES could be considered. Air capability could be a key selection factor for such a craft.

Foreign Military Sales, to Latin America in particular, may be an attractive arena for marketing of SES patrol craft. Note should be taken of the Nor-test consortium approach in Norway for a 220-ton fast-attack craft.

ASW

As previously discussed, a "small" U.S. ASW platform would likely be in the 1500 to **2500-ton** range which would represent a large step in scale for near-term consideration.

MCM

It is anticipated that performance of the Norwegian SES **MCMs** will be closely observed by the U.S. The NATO **SWG/6** SES MCM study is continuing. Current acquisition planning, however, is expected to preclude consideration of SES in the near term.

Other

Workboats, fireboats, survey boats and offshore supply craft are among the logical candidates for SES. These craft are generally within current state-of-the-art with respect to speed and displacement, so it is simply an issue of cost effectiveness.

ACKNOWLEDGEMENTS

The authors acknowledge the contributions of the following companies and government agencies. Without their contributions including photographs, preparation of this paper would not have been possible.

Companies and Government Agencies

Blohm und Voss
Brodrene **Aa**
Cirrus
Fincantieri
Hovermarine International
Karlskronavarvet
Marinetechnik **GmbH**
Royal Schelde
Societa Escercizio Cantieri, **SpA**
Service Technique Des Constructions et Armes
Navales
Trinity Marine Group
Ulstein International

The authors also acknowledge the contributions made by:

Bill Band (BLA), John Allison (BLA), John Adams (**MDI**), Charles Atchison (NAVSEA **501**), Tom Cannon (NAVSEA **50141**), Alan Ford (DTRC **12**), Chris McKesson (NAVSEA **50 141**), Jack Offutt (DTRC **12**), Pat Smith (MDI), Steve Wynn (NAVSEA **50141**), Norman **Polmar** (U.S. Naval Institute) and the technical publications effort by Linda Peters (BLA).

Mr. John Lewthwaite is also acknowledged for his review of, and valuable contributions to, the paper.

The publications: "Janes High-Speed Marine Craft" (Reference **5**), "Fast Ferry International" (Reference **6**), and "Work Boat World" (Reference **49**) are also acknowledged as very valuable sources of information used in the preparation of this paper.

REFERENCES

1. Hayward, L, "The History of Air Cushion Vehicles," Kalerghi **McCleary** Publications, London, 1963.
2. Trillo, R.L., "Marine Hovercraft Technology," book published by Leonard Hill Books, London, 1971.
3. Mantle, P.J., "Air Cushion Craft Development," book published by DTNSRDC, No. **80/012** (4727 Revised), 1980.
4. **Tattersall**, E.G., "The History and Future of the Surface Effect Ship in the United Kingdom, A Personal Account," Naval Engineers Journal, Volume **94**, Number **2**, ASNE. April 1982.
5. "Janes High-Speed Marine Craft," (Issues 1971 to **1990**), Jane's Information Group Ltd, Editor, Robert Trillo; Sentinel House, 163 Brighton Road, Coulsdon, Surrey, CR5 **2NH**, UK.
6. "Fast Ferry International," formally "High-Speed Surface Craft," and "Hovering Craft and Hydrofoil," (Issues 1961 to **1990**), High-Speed Surface Craft Ltd, Editor Alan Blunden, 24 Leaf Close Northwood, Middlesex, HA6 **2YY**, UK.
7. "Air-Cushion Vehicles," (Issues 1963 to **1971**), Horizon Publications Ltd, Somerset, UK (formally a Flight International supplement).
8. Tattersall, E.G., "The HM 500 Series of Sidewall Hovercraft," Royal Institution of Naval Architects, April 1984.

9. Ford, A.G., "Captured Air Bubble (CAB) Vehicle Progress Report," **AIAA** Journal of Hydronautics, April 1968.
10. Mantle, P.S. and Lavis, D.R., "Domain of the Air Cushion Craft," SAE Paper 680273, April 1968.
11. Chaplin, J.B., "A Rational Approach to an SES Design," **AIAA/SNAME** Advanced Marine Vehicle Conference, Paper No. 79-2032, October 1979.
12. Chaplin, J.B., "Development of the Bell Halter 110 SES," Journal of Hydronautics, Volume 15, No. 1-4, January - December 1981.
13. Sara, A. CDR, USCG, Presentation given to the U.S. Hovercraft Society on experience with U.S. Coast Guard WSES Cutters, April 1990.
14. Spaulding, K.B., Jr., "The CONFORM Program • An Update," Naval Engineers Journal, May 1984.
15. Spaulding, K.B., Jr., "SES and ACV for Naval Missions - The CONFORM Studies," presented at the 1985 Joint International Conference on Air Cushion Technology, Rockville, Maryland, September 1985.
16. "Soviet SES Combatant Joins Growing Air-Effect Fleet," Navy News and Undersea Technology, Volume 7, No. 28, 23 July 1990.
17. Gullberg, O., "Jetrider SES 300 Passenger Ferry Development," Canadian Aeronautics and Space Journal, Volume 35, No. 2, June 1989.
18. Salomonsson, L., Bergman, M. and Nilsson, J., "The 'TESTRIGG' Vessel • A Consequence of Futuristic Ideas," Karlskronavarvet (KKrV), Sweden.
19. Knupffer, K., **Frambourg**, J., **Lewthwaite**, J. and Adams, J., "SES 700: The Federal Republic of Germany's Fast Test Craft," Intersociety Advanced Marine Vehicle Conference, Arlington, Virginia, June 1989.
20. **Lewthwaite**, J., Presentation to the (UK) Hovercraft Society, Hovercraft Bulletin, February 1991, The Hovercraft Society, 24 Jellicoe Avenue, Alverstoke, **Gosport**, Hants, PO1 22PE.
21. Lavis, D.R., Rogalski, W.W. and Spaulding, K.B., "The Promise of Advanced Naval Vehicles for NATO," Marine Technology, March 1990.
22. Code of Safety for "Dynamically Supported Craft," (Resolution A 373 (X) not yet ratified by all countries), International Maritime Organization (IMO).
23. "Rules for Classification of High-Speed Craft," Det norske Veritas, **1985** (Draft Revision Issued for Review, January 1990).
24. White, W.N., "Advanced Marine Vehicles • A Review," Section III Surface Effect Ship (SES), 23rd Annual Technical Symposium, NAVSEA, Association of Scientists and Engineers, April 1986.
25. Lavis, D.R. and **Forstell**, B.G., "Computer-Aided Conceptual Design of Surface-Effect Ships," Canadian Aeronautics and Space Journal, Volume 35, No. 2, June 1989.
26. Band, E.G.U. and Lavis, D.R., "Computer-Aided Design of Air-Cushion Vehicles and Surface-Effect Ships," International High-Performance Vehicle Conference, Shanghai, Nov. 1988.
27. Lavis, D.R. and **Bagnelli**, D.G., "Computer-Aided Early-Stage Design of High-Speed Craft," Intersociety Conference, Arlington, Virginia, June 1989.
28. Durkin, J.M., "An Experimental Investigation of the Performance of the Aerojet 1/4-Scale, Variable-Geometry Centrifugal Lift Fan Under Dynamic Flow Conditions," DTNSRDC Report 76-0073, June 1976.
29. Moore, R.G. and Omega, G.T., Bell Aerospace Textron, "Large SES Design Limits," ATAA, Spring 1979.
30. Newman, J.N. and Poole, F.A., "The Wave Resistance of a Moving Pressure Distribution in a Canal," DTNSRDC Report No. 1619, March 1962.
31. Doctors, L.J., "The Wave Resistance of an Air Cushion Vehicle," University of Michigan, December 1970.

32. Allison, J., "Propellers for High-Performance Craft," SNAME Marine Technology, Volume 15, No. 4, October 1978.
33. ISO 2631, "Guide for Evaluation of Human Exposure to Whole-Body vibration," International Standard Organization (ISO) Document ISO/DIS 2631, 1972.
34. O'Hanlon, J.F. and McCauley, "Motion Sickness Incidence as a Function of the Frequency and Acceleration of Vertical Sinusoidal Motion," Human Factors Research Inc., Technical Report 1733-1, September 1973.
35. Allison, J., "Air Cushion Vehicles and Surface Effect Ships for Great Lakes and Great River Transportation," SNAME Marine Technology, November 1990.
36. Adams, J.D. and Beverly, W.F., "Technical Evaluation of the SES-200 High Length-to-Beam Surface Effect Ship," Naval Engineers Journal, Volume 96, Number 3, May 1984.
37. Butler, E.A., "The Surface Effect Ship," Chapter VI of "Modern Ships and Craft," published by The American Society of Naval Engineers as a special edition of the Naval Engineers Journal, February 1985.
38. Wilson, R.A., "Captured Air Bubble Vehicle Stability Tests," AIAA/SNAME Advanced Marine Vehicle Meeting, Norfolk, Virginia, Report No. 67-349, Macy 1967.
39. Lavis, D.R., Band, E.G.U. and Hoyt, E.D., "Development of Intact Stability Standards for Rigid Sidehull Surface-Effect Ships," USCG Report No. CG-D-53-81, December 1981.
40. Blyth, A., "Recent Research into the Ultimate Stability of Surface-Effect Ships," RINA Conference on Ship Stability and Safety, June 1986.
41. "Report of the ARB Special Committee on Hovercraft Stability and Control," Civil Aviation Authority, CAA Report 75017, June 1975.
42. Lavis, D.R., Bartholomew, R.J. and Jones, J.C., "On the Prediction of Acceleration Response of Air Cushion Vehicles to Random Seaways and the Distortion Effects of the Cushion Inherent in Scale Models," AIAA Paper 72-598, July 1972.
43. Band, E.G.U. and Lavis D.R., "Heave Stability of Air-Cushion Supported Ships," PRADS' 89 Conference, Varna, Bulgaria, October 1989.
44. Band, E.G.U., Lavis, D.R., Giannotti, "Prediction of Hydrodynamic Impact Loads Acting on SES and ACV Structures," AIAA Paper 76-868, September 1976.
45. Band, E.G.U. and Baca, A.F., "Predicting the Unpredictable - Development of Rational Design Loads for High-Performance Vessels," Hovering Craft and Hydrofoil Exhibition, Brighton, England, June 1980.
46. "British Hovercraft Safety Requirements," Civil Aviation Authority, Surrey, England.
47. "ABS Proposed Rules for High-Speed Craft," American Bureau of Shipping, Draft Issued for Review, March 9, 1989.
48. Allen, R.G. and Jones, R.R., "Considerations on the Structural Design of High Performance Marine Vehicles," New York Section, SNAME, January 1977.
49. Work Boat World, Page 10, by George Marsh. Published by Baird Publications, Eastgate House, Town Quay, Southampton, SO1 LX, UK.
50. "A Guide for Implementing High-Speed Waterborne Passenger Transportation Services," Urban Mass Transportation Administration (UMTA), Office of Technical Assistance, September 1984.
51. "Overview of Coast Guard Plan Review for High-Tech Ship Design," James A. Watson and William M. Hayden, paper presented to the Chesapeake Section of SNAME, 22 February 1989.
52. "Leisure Industries Promote Increased Activity," The Motor Ship, January 1991.
53. Spaulding, K.B., Jr., "Cored Fiberglass Reinforced Hull Construction," Conference on Fishing Vessel Construction Materials, Montreal, October 1968.
54. Svensen, R., "Experience with the KaMeWa Waterjet Propulsion System," Intersociety Advanced Marine-Vehicle Conference, Arlington, Virginia, June 1989.

55. Oehlmann, H. and Lewthwaite, J.C., "The Prediction of Resistance of Surface Effect Ships," FAST 91, Trondheim, Norway.
56. Goubault, P., Oehlmann, H., Lavis, D.R. and Goetsch, W., "Comparative Parametric Studies of **Monohull** and Surface Effect Ships," presented at FAST 91, Trondheim, Norway.
57. Knupffer, K., Reischauer, J. and Witschel, H., "SES Technology," SMM-1990 Conference, **HANSA** Sonderdruck, Germany.
58. Kaplan, P. et al, "Dynamics and Hydrodynamics of Surface Effect Ships," SNAME Transactions, Volume 89, pages 211 - 247, 1981.
59. Clayton, B.R. and Tuckey, P.R., "A Speed Control System for High-Speed and High Power-to-Weight Ratio Motors With Specific Application to Model Hovercraft **Lift Fans**," High-Speed Surface Craft, June 1982.
60. Clayton, B.R. and Tuckey, P.R., "Dynamic Response of Hovercraft to Regular Wave Excitation," High-Speed Surface Craft Conference, May 1983.
61. Clayton, B.R. and Webb, R., "The Dynamic Response of Surface Effect Ships in Regular Head Seas Using Model Simulations," Fifth International High-Speed Surface Craft Conference, May 1986.

LIST OF SYMBOLS AND ABBREVIATIONS

AALC	Amphibious Assault Landing Craft
A_c	Cushion Area (ft²)
ASW	Anti-Submarine Warfare
B	Beam Overall (ft)
B_c	Cushion Beam (ft)
B_H	Maximum Craft WL Beam Hullborne (ft)
BLA	Band, Lavis & Associates, Inc.
B_s	Sidehull Width Amidships at Hullborne Waterline (ft)
C_b	Sidehull Block Coefficient

C_p	Sidehull Prismatic Coefficient
CG	Center-of-Gravity
D	Freeboard (ft)
d	Draft (ft)
DTRC	David Taylor Research Center
g	Acceleration Due to Gravity (32.2 ft/sec²)
H_c	Cushion Height Amidships, Keel to Wet-Deck (ft)
K	Roll Radius of Gyration
KBS	Kamysh-Burun Shipyard, USSR
KG	Vertical Center-of-Gravity (VCG) Height Above Keel
KKrV	Karlskronavarvet
L	Length Overall (ft)
LACV-30	Lighter Air Cushion Vehicle (30-Ton Payload)
L_c	Cushion Length (ft)
LCAC	Landing Craft Air Cushion
L_{wl}	Sidehull Waterline Length on Cushion (ft)
MDI	Maritime Dynamics Inc.
MTG	Marinetechnik GmbH
N	Pump Speed, rpm
NAVSEA	Naval Sea Systems Command
NPSH	Net Positive Suction Head, ft
N_{ss}	Suction Specific Speed (a Quasi-Dimensionless Number)
P_c	Cushion Pressure (lb/ft²)
Q	Pump Flow Rate, gpm (by convention)
RNN	Royal Norwegian Navy

SEC **Societa** Escercizio Cantieri, SpA

SSPA Maritime Consulting AB

TCG Transverse Center-of-Gravity

VCG Vertical Center-of-Gravity

W Full-Load Displacement (L. Tons, lb)

W (1/2) Half the Full-Load Displacement (lb)

α Sidehull Outer **Deadrise** Angle Amidships (degrees)