

Adding Hydrofoils To Motorboats (Kits?)

Descriptions, Advice, Sources of Information, and Requests For Help

(Last Update: 11 Nov 03)

- This is the archive of messages posted before IHS initiated an automated BBS for correspondence
 - [Click Here to go to the Posted Messages Bulletin Board \(BBS\)](#)

Books About Hydrofoils -- [Click Here](#)

Magazine Articles About Hydrofoils -- [Click Here](#)

[Click Here](#) for info on an automatically controlled, fully submerged hydrofoil system added to a Bayliner

Note: See also, [Up-Right Hydrofoil Kits, by Tom Lang](#) (Includes advice for adding hydrofoils to motorboats)

[Suggest Additional Reference\(s\)](#)

More Hydrofoil Sources...

For Hydrofoil References in Technical Journals, Papers, and Books, [Click Here](#)

For More Bibliographies, Especially Sailing Related, Start With the [IHS Links Page](#)

Of course every IHS Newsletter is packed with articles about hydrofoils. To view an index of past articles in MS Excel format, [Click Here](#)

Posted Messages

Foil Design Tool Needed For 10-Meter Cat

[3 Feb 02] I am very interested in a hydrofoil design for a 10-10.3 meter catamaran hull design which will be used for fast surveillance and medi-vac. Do you know of any design software available that our manufacturer can purchase and use? It would be most helpful if any of your reader/contributors could point me to several sites for both Catamaran Hull and Hydrofoil design software (preferably Windows Based). -- Tom Barrett, Project Shared Services, BP West Java, Ltd. (barrett@BP.com)

Response...

[13 Feb 02] For the past 4 years I have been working just such a design tool, as I have just completed my PhD on design of hydrofoil-assisted catamarans. The tool I am talking about uses the vortex lattice method. You can look at the website: www.cl.spb.ru/taranov/. For more information on the code you should contact Prof. Nikolai Kornev: nikolai.kornev@mbst.uni-rostock.de. Recent additions to the code are models for hydrofoil-assisted catamarans that take the full vortex-wave-wake interactions between the hull and the foils into account. If you interested in only one design, you may be more interested in getting someone to do the design for you as it takes substantial time to familiarize yourself with firstly with the hydrodynamics involved and also with the use of the code. -- Günther Migeotte (gunther@cae.co.za)

[17 Feb 02] I searched the web site before and exchanged e-mail with Mr. Kornev. He has a hydrodynamic software to predict the performance of the hydrofoil and its interaction with the hull. If I remember right, the software covers some wing in ground effect design too. Cost: ~US\$6,000. -- Weimin Hu whu@JJMA.Com

Adding Foils to 46-Foot Engine-Powered Catamaran

[3 Feb 02] I own a 46-foot motor cat which I am currently wanting to fit foils to. Wondering whether you could offer foils shapes and/or design or a site where I could find relevant information to design and construct. The vessel is powered by 2x400 horse power Cummins with a current speed obtained of 17 knots and a displacement of 18 to 20 tonnes. The main foil length between the hulls will be 1.45 metres long with the 2 aft foils approximately .5 metre long each and adjustable. Appreciate any help you can offer. -- Ian Gallaway, High C Marine, Australia (highcmarine@msn.com)

Adding Foils to a Yacht

[13 Jan 02] Can anyone tell me if I could expect any additional fuel efficiency by adding foils to a mid sized displacement or semi-displacement yacht?? For example, a 55-ft yacht with roughly 60,000lb displacement. I'm considering a trans-oceanic trawler style which would normally cruise at 7-8kts for maximum range. I'm wondering if adding foils would allow me to attain the same range at a slightly higher speed. Bearing in mind the old rule that you can go fast, or you can go a long way but you can't go a long way fast (without burning inordinate amounts of fuel), I'm trying to figure out whether a hydrofoil configuration affects this tradeoff to my benefit. I understood from other posted messages that at somewhere around 15kt you can get almost anything foilborne. I'm not so much concerned about hitting 30-40 kts as I am in knowing whether I could hit the 15-20 kt mark with the same fuel efficiency that I would with a

displacement hull at just below hull speed, or at least close enough to make the trade worthwhile. This is all very advanced planning at the moment. If I want to do truly global cruising without breaking the bank I figured I'd need either some sort of cat or accept the slower speeds of a displacement hull. I'm hoping a hydrofoil option might provide an elegant compromise between speed and efficiency. The foils would have to be surface piercing because of the stability factor. Dynamic controls are just one more thing that can go wrong in the middle of nowhere. I figure I'd worry about retractability and stuff like docking if the concept proves valid. If a hydrofoil worked within my boundary conditions, the idea would be to use a semi-displacement hull powered to achieve the take-off speed for the foils. Hopefully then the power requirements would drop dramatically and I could achieve acceptable fuel efficiency. I trawled the foils.org site but was unable to locate any numbers relating to the efficiency of a hydrofoil viz a similar displacement style vessel. Do you know if anyone has some numbers relating to fuel efficiency in existing craft ?? If so, I might be able to draw some inferences that would tell me if this is worth pursuing -- Gregory Nicholls (gnycholls@bellsouth.net)

Responses...

[13 Jan 02] I don't see any way for foils to assist in this case at such low speeds - the dimensions would need to be huge to generate significant lift. You will need to do some calculations that involve looking at the rough hydrofoil dimensions, section shape and lift coefficients that might be expected. I don't see you going from 7-8 knots to 15 knots economically since the foils may not generate enough lift. Also, you will have the additional navigational draft to contend with if the foils are fixed (not retractable). If the foils are large, they will also damp out pitch motions in waves, which could cause deck wetness issues forward. -- Mark Bebar (bebar@foils.org)

[13 Jan 02] I have given your problem some thought. Fuel efficiency boils down to drag. Without going into a detailed analysis, I would say it is NOT advisable to put foils on a craft in the speed range of 7 to 15 knots. The reason for this is simply that the Lift to Drag ratio (L/D) of your current hull probably is in the range of 20 to 8 for the speeds of 7 to 15 knots respectively. A fully-submerged foil system is really best at speeds greater than 25 knots. At the lower speeds, the L/D of a fully submerged foil system will not be much better, maybe worse. For foils to provide 60,000 lb of lift at 15 knots with a lift coefficient of 0.20, the foil loading would have to be very low; like 128 lb/square foot. Normal foil loadings for 30 to 50 knot hydrofoils are up about 1000 to 1200 psf. The total foil area would have to be 468 sq ft. If you split the lift between the forward and aft foils at 0.3 and 0.7 respectively, I get foils like: Forward: Span = 28 ft, average chord = 5 ft Aft foil: Span = 41 ft; chord = 8 ft. These are very large foils for your size boat. The foils would be relatively heavy and produce a lot of friction drag. I doubt if you could get a L/D much more than 9 or 10 at 15 knots. It would be less at 8 knots. In fact it might not take off at 7 or 8 knots. Struts would have to be added of course, further increasing weight and drag. Also, you need to get the power into the water through an inclined shaft or a Z-drive. The inclined shaft would add more drag. A Z-drive introduces complexity, and special gears. Remember that Advanced Marine Vehicles (AMVs) are designed to go fast. Conventional hulls are great for low speeds, so may as well stick with it for now until you want to get up to 30 or 35 knots and are prepared to put the power into the boat. I advise purchasing (\$5) the AMV CD-ROM offered on the IHS website. It has related technical info that you can pursue as you desire. -- John Meyer (jmeyer@erols.com)

[13 Jan 02] As I see it, L/D is the issue, but it's not necessary for the foils to lift the boat out of the water. The L/D of the hull goes to infinity as the speed decreases, so below a certain speed nothing will beat a displacement hull and hydrofoils will just add drag and be a liability with their tendency to foul on anything in the water. For the trawler hull mentioned, you'd have to know how sensitive the drag was to a change in displacement at the desired cruising speed and then see if a hydrofoil could be designed to pick up part of the displacement with lower drag. The trawler hull's drag will increase rapidly with speed, but I don't know whether it will drop rapidly with a reduction in displacement. Trawler hulls have the reputation of being insensitive to weight, so I doubt the hydrofoils would be able cut the drag enough to make much of a speed difference. I ran into this issue with my hydrofoil sailboat design. I was aiming for a takeoff speed around 8 - 10 kt, but the design tradeoffs indicated that the boat had less drag hullborne than it did foilborne to a much higher speed. Those hulls are very narrow, so it's possible to drive them to the higher speeds. With their small waterplane area, they are sensitive to weight, too. So hydrofoils make more sense for that situation. If you want more speed, have you considered going to a catamaran? More speed, more room, and more comfort, too. But maybe less payload. Cheers, -- Tom Speer (me@tspeer.com); website: <http://www.tspeer.com>

[15 Jan 02] At 15 knots and 60,000 lb., you would need a minimum foil area of over 65 ft² (assuming a lift coefficient of 1.5, optimistic, 100 ft² if lift coefficient is 1, realistic). More would be required to get on foil. This is a lot of area. More important than the lift to drag ratio, these things would take up a lot of space, particularly if retractable. The structural support of these would be horrendous. All of this will take up significant space and weight on your boat. Why do you need 55 ft and 60,000 lb? If it is to carry stuff, to carry there foils you would need to increase size further (maybe 60' and 78,000 lb)? You then need to be 30% more efficient just to break even on fuel. If you don't need the extra size, cut the size and weight of the vessel to save fuel. At this size, with a well-designed semi-displacement monohull, you can cruise fairly efficiently up to 9-10 knots (although 7-8 would be even more economical). If you want to go a little faster, putting on some over sized trim tabs or a large wedge (similar to the wedges going onto the destroyers and cruisers) might help more than foils. Getting a well-designed boat for the speed you want to run can make a big difference. -- Rich Wilson

[15 Jan 02] I agree with Rich. Why 55', 60,000 lbs and 15kts? While there were hydrofoils built about that size (Hitachi PT-20, 68', 32.5 tons, surface piercing foils & Italian RHS-70, 72', 31.5 tons, surface piercing foils), their average cruise speeds were around 32 knots and not intended for global cruising. As Rich points out, there are better ways to save fuel. -- Dave Pogorzelski

Height Sensor for Automatic Control System (ACS)

[16 Dec 01] I have a question on the height sensor that is actually used on the PHM. Can you tell me what the sensor is called and who made it? I am curious as to what physical principle is the basis for the height sensor. I think that filtering was done to in essence compute the average wave height. Is anybody doing any redesign of the control laws or the redundancy management in the flight control system? Perhaps newer computers are being used. This might be of interest to me as I do consulting in the area of guidance, navigation and control for mostly aerospace applications. I used to work for Doug Fosth in the Flight Controls Group that he headed in the mid-1970s. I did my EE Master's thesis on analytic sensor fault detection via observer theory for

dissimilar sensors. I only considered the lateral/directional dynamic model. The roll gyro is the most important sensor. The objective was to save money by reducing the triple redundant system to double redundant and synthesizing the missing data through the magic of Luenberger Observers or Kalman filters. The technical paper was written on the topic in Aerospace and Electronic Systems of IEEE in about 1975. The authors were Fosth, Clark and Walton. This paper was one of the first in the area of analytic redundancy and now finds application in a similar form onboard the Boeing 777 air data inertial reference system angle of attack sensors. I still work for Boeing in Flight Controls Research in the commercial division. When I was going to college in the late 60's and early 70s both the Lockheed and Boeing hydrofoils were stationed at Puget Sound Naval Shipyard. As an engineer trainee I had an engineering assignment on the Lockheed boat. -- Vince Walton, VMW Systems Dynamics (vwalton@sprynet.com)

Responses...

[16 Dec 01] I am not a controls type, so I will try to answer your question to the best of my knowledge. The height sensors used on PHM were originally designed and built by Boeing. Basically, the output was 10 mv/ft. On the *HIGH POINT*, we tested various altimeters from different manufacturers, and concluded that the TRT radio altimeter (modified for the 10 mv/ft output) was the least susceptible to outside interference, and thus was installed on the PHMs. The Automatic Control System (ACS) had the filtering network for all the sensors, including the height sensor. The height signal was primarily compared to the height set, and input into the forward foil. Pitch and roll controlled by the aft foils primarily followed the forward foil with the vertical gyro, accelerations, and rate gyros tempering the signal. All Boeing-built hydrofoils used essentially the same principle but the filtering network was different in each class due to ship responses because of longitudinal positioning of the fore and aft foils, hydraulic control response time, sensor positioning, etc. all which were simulated in a computer to optimize the gains and filtering schemes. One of the modifications we made was to relax the control loop since the hydraulic system was being shaken to early failure. The modification was also noted in the ride, where vibration was considerably reduced and yet, no detrimental effect of control was noticed. As for the actual filtering network and gains for the PHM, the ACS drawings will provide the information. As for new designs, many hybrids are using control systems for ride control. I am not familiar with the designs, thus cannot comment on them. *HIGH POINT* did fly using an IBM 8086 computer with a program compiled from BASIC as the ACS computer. Analog to Digital and Digital to Analog devices were used to tie into the existing ACS to demonstrate that a digital control system could be used successfully. I hope I have answered your question. -- Sumiyasu Arima (arimas1@juno.com)

[24 Jan 03] Please could you tell me where I can get hold of suppliers / manufacturers of these TRT radio altimeters? We are looking to perform the same monitoring on our hydrofoil boats and have not been able to find any sensors capable of measuring the boat's height above the water's surface during test runs. -- Andrew Wade, Centre for Automotive Engineering (adwade@cae.co.za)

[24 Jan 03] I have been retired for over 13 years now and have not kept up on such things as suppliers. TRT is a French company that was represented by Sundstrand in the United States over 20 years ago. I do not know who represents this firm at the present time. I remind you that

the units used on the hydrofoils had a modification installed by TRT to provide 10mv/foot output. -- Sumi Arima (arimas1@juno.com)

[26 Jan 03] I believe the height sensor you have been referring to is a RADAR height sensor, not a RADIO sensor. I remember a report about it (I believe called ANV-20) written by HYSTU. I've seen it on my book shelf recently, but can not put my hands on it at this moment. Will let you know if I find it. -- John Meyer (jmeyer@erols.com)

[26 Jan 03] You are correct re height sensor. See pages 123 & 178 in my book *Twenty Foilborne Years*. -- [Bill Ellsworth](#) [*Editor's note: Bill Ellsworth's book is included in the Advanced Marine Vehicle (AMV) CD-ROM #1 offered for sale to the public by IHS*]

[27 Jan 03] If you do not have any luck with TRT, there may be other possibilities:

1. There is a Japanese company named TSK that produces a wave height sensor system based on the use of microwaves. This is intended mainly for wave height measurement from the bow of a ship and was not intended as part of an autopilot system so I don't know if it would meet your requirements.
2. There are many search and rescue helicopters that have radar altimeters fitted to aid in coming to a hover near to sea level at night or in poor visibility. Perhaps such a radar altimeter could be adapted for your purposes? I don't know who manufactures those.
3. The operators of Boeing Jetfoil hydrofoils would surely know a source of spare parts or maintenance for similar height sensing units. Perhaps you could contact one of them for help? A company in Hong Kong operates what would be the largest Jetfoil fleet in the world.

-- Martin Grimm (seaflyte@alphalink.com.au)

[27 Jan 03] If you read my original message, I did not specify what type of altimeter it was. I believe TRT calls it a Radio Altimeter. Additional information for Andrew Wade, during our tests, we used other aircraft altimeters to evaluate. I remember Bendix and Sundstrand had one. The TRT unit was selected for the anti-jamming capabilities. All altimeters will work if jamming or interference from other sources is not of concern. All you need is a scaling network to adapt to your control electronics. -- Sumi Arima (arimas1@juno.com)

[28 Jan 03] Thanks for the info. I've found what I was looking for at the International Institute for Advanced Aerospace Technologies (IIAAT) of State University of Aerospace Instrumentation (SUAT) in Russia, headed by Prof Alexander Nebylov and at TSKA Inc. in Washington State. The IIAAT of SUAT makes custom devices for measuring flight height (and any other parameters you might need) while TSKA makes the "TSK Remote Wave Height Meter" that measures the height of waves passing the boat, using microwaves and an accelerometer to compensate for the ship's motion. The accelerometer is optional if the height from the bow to the water's surface is required. -- Andrew Wade, Centre for Automotive Engineering (adwade@cae.co.za)

Hydrofoil Pontoon Boat Project

[11 Nov 01] I'm working full-time adapting a 28' aluminum pontoon boat with a fully-submerged hydrofoil system. I'm estimating an empty weight of 3300# plus a 10 (1500#) passenger load (max). I am to power it with a 150-220hp extended-foot outdrive. I am looking for 15-20 mph lift-offs and smooth operation in 2-2.5' chop with a 45+mph cruise. The foils are to be located fully fore & aft on the craft, with weight 40-60%, changing with the passenger loading. The rear foils will be mounted to and pivoting with the outdrive (for manual pitch adjustment) and have opposite operating trim tabs for roll control. The front foil will be steerable and use foil (and strut) incidence control to adjust the craft's height. It will use a homebrew electronic/hydraulic automatic flight controller. I've poured through every word on this site and am working my way through the CD, but still questions remain. What would be good target wing loadings? If I approximate an NACA-6 series foil, does anyone have experience "hand" machining it from alum bar stock? Is another foil shape "good enough" but significantly easier to build? (I've been unable to find manufactured foils.) What angle of attack pitch range would I likely need for each foil? Is there anyone out there who might occasionally offer me some "shoot from the hip" guidance as this project progresses? I'll gladly assemble a photo essay for others who like myself, might also follow in Harry Larsen's footsteps. -- Barry Steele (barry_steele@yahoo.com)

Responses...

07 Aug 03] Did you complete your pontoon hydrofoil? I have a 24 ft. pontoon boat that I have modified to represent my idea of a pool side, i.e. an eight-foot spiral pool slide in the rear and an oval table in front surrounded by captain's chairs. The problem is that I now have more weight up front than in the rear and it rides bow-heavy. I would like to add something like a hydrofoil to bring the bow up a little. I am not really wanting to bring the whole boat out of the water, just improve the ride. Do you have any suggestions? I have a molded plastic foil that I had on the 85hp outboard when it was on a 16ft runabout. It worked great for planing out with a skier and I thought perhaps it could be adapted to the pontoon boat problem. I could fabricate something if necessary, but it would have to be pretty simple. Any advice would be appreciated. -- Rick Fahey (Rfahey@sauer-danfoss.com)

[11 Nov 01] During the summer of 1960 while still in college, I worked for Dynamic Development Inc., which was the hydrofoil development partner with Grumman. At the time Grumman provided financial backing, and DDI provided the know-how. Grumman teamed with DDI had won the MARAD (Maritime Administration) contract for the *DENISON*, and in the summer of 1960 DDI was building a 1/5.5 scale open water test model of the future *DENISON*. The model was called *GREAT EXPECTATIONS*. The foils were hand machined from thick aluminum plate using an in house fabricated rig which used a router with a straight bit as the major cutting tool. The face plate of the router was attached to a 1/4" aluminum "runner" plate, which ran on two lengths of aluminum tube guides. The two outer edges of the runner plate each had an 8" to 10" length of larger diameter tube attached by brazing. The inner diameter of these short tubes matched the outer diameter of the guides. If I remember correctly these short tubes were sliced longitudinally to allow for adjustment of the diameter by squeezing. The router could then run back and forth on the guide tubes. At each end of the guide tubes were inserted into 1/4" plates perpendicular to the tubes. At one end they were brazed. At the other end they simply

passed through holes matching the outer diameter of the guide tubes. In each of these plates were drilled two holes for bolts. These bolts supported the rig and router between two foil section flat plate templates. The foil templates were positioned beyond the ends of the foil section being machined. Each template had a series of drilled holes with a maximum spacing not exceeding the diameter of the cutter. The hole locations were calculated using the geometry of the router rig, and the desired contour of the foil. The foil section was rough machined by manually moving the router with the cutter at a constant fixed depth along the guide tubes, and repositioning the end plates after each cut. Each pass would provide a flat cut; the center of which was on the foil final contour. Following the rough machining, the final contour between the router cuts was achieved by hand filing and sanding. The *DENISON / GREAT EXPECTATIONS* main foils were surface piercing, and using this method each section was independently produced and joined together. The method described obviously can only be used for straight or tapered constant section/variable chord foils of easily machined material. If I were to design a rig today, I would try to eliminate or modify the bolt attachment method between the end plates and the templates. On tapered foils there was a limit to how close the hole pattern could be on the template for the narrow end. This resulted in a large of hand filing on the wider end of the foil. I had thought at the time of using two series of "high/low" holes to double up on the number of router passes to next time. But this method was used on only one set of foil. Everything subsequent was NC machined. One alternative may be to use "male/female" templates, with one template attached to the end plate and the other template attached to the working surface. If the two templates were clamped in some fashion, this could provide infinitely variable spacing between router cuts, and eliminate most of the hand finishing. Hope this helpful and not too confusing. Let me know if it is, and I can send a sketch. -- Charlie Pieroth (SoundTM@ix.netcom.com)

[11 Nov 01] The plan seems almost identical to [TALARIA III](#). Just the hull is different. Planned top speed is considerably higher. (I am making some improvements to *TALARIA III* that should increase its top speed somewhat.) Some thoughts: Make sure the design has enough roll authority at takeoff. It depends on foil span, weight distribution, and control surfaces. Use gold connectors for the electronics. Work the corrosion problem. I believe the takeoff speed he has specified will dictate that the foil loading to be low. Konstantin Matveev's lift mathematics (in EXCEL) is on *TALARIA III*'s web site. He can check what load is required for take off with the program. *TALARIA III*'s aft foil was "hand" machined out of a 1" x 8" aluminum bar by rotating the milling machine's head and taking several passes. It was a long time ago, but I think it took about half a day to do the machining. I am currently investigating the shape for a new aft foil. I would be interested in your conclusions. Following are answers to specific questions that you submitted to me:

- *Q - I know you used a forward "wave skimmer". Did it exclusively control the boat height (pitch) mechanically? Did it feed back to the flight control? And what did you use for your input systems for height, roll and yaw? A - Yes, the "wave skimmer" controls the height mechanically (low feedback), exclusively. Height is not fed back to the controller. Roll uses an inclinometer. Also it has a solid state rate gyro for roll rate. Rudder (front strut) position is fed to the autopilot. The sensor is a LVDT. If you check the parts list on my web site these (some) are listed and their source.*

- *Q - I read that you were using a hydraulic steering control, but was there an interaction between that and any roll control? A - Yes, the rudder position is differentiated by the autopilot and used to anticipate the roll into a turn. The "hydraulic" steering is only used to eliminate feedback from the front strut to the helm. It is not powered.*
- *Q - What were your controlled surfaces, and how did you move them? (I'm considering Mercruiser trim/tilt motors & cylinders. or a pressurized water system & firestone bladder cylinders) A - Not sure I understand the question. Roll attitude is controlled by the flaps on the aft foil. They are actuated differentially by hydraulic actuators. They are controlled by a Moog servo valve. I did some experimenting with an electric motor/pump system on an earlier test boat. The response time was way too slow, e.g. .3 sec. When you derive your control law check to see how much lag you can have. For *TALARIA III* only a servo valve had the required response, e.g. 15+ hertz.*
- *Q - Were your outputs proportional, simply on/off, or were you controlling duty cycle? A - The output to the servo is continuous pulse width, partially smoothed. This takes care of the dither requirement of the servo. Q- Could you "set & forget" the rear foil angle of attack (was incidence control required)? Were there trim tabs for roll control? A - The rear foil angle is adjustable but this feature is seldom used (only for test purposes). The bow ski controls height. The aft foil flaps control roll angle. They are full span.*
- *Q - What parts of the control system (algorithm & hardware) gave you the most trouble or was the most sensitive? A- The ADC interface to the laptop and corrosion. Gold connectors, solder everything else.*
- *Q - What would you try to change if you were to do it again? A - I have been upgrading the boat since its first flight. Last year I replaced the belt driven hydraulic pump with one directly coupled to the engine and simplified the hydraulic manifold. I am currently working on the design of a new aft foil. I would not have changed the plan I followed. Each of the steps was necessary to get the boat flying quickly. And although I have changed parts it was not because they didn't work.*
- *Q - If I were to use a CPU for processing, how many adjustments do you think would be required per minute? A - In the mid/early 1980s, on an earlier test boat, I had a digital controller (C64). It was able to marginally fly the boat with it operating at 10 hertz. I went to an analog system because at the time there were no computers fast enough. I would suggest that the cycle rate be around 50 to 100 hertz, (.01sec lag). That added to the servo valve's lag must be kept below (depending on your design) say .03 to .05 sec. When you calculate your control law you can check to see how much lag you can have while maintaining control stability.*
- *Q - Any other suggestions? A - You could ask Malin Dixon about his controller.*

I would be pleased to hear of your progress and to respond to any further questions you may have. -- Harry Larsen (talaria@foils.org)

[11 Nov 01] The paper I wrote for the *Proceedings of the 25th Anniversary Celebration and Conference* entitled "Hydrofoil Ship Load Criteria Development: A Retrospection" (pp. 107-125) presents in Figure 2 maximum attainable loading on PHM-1 aft foil vs speed for 0 and 20 degree flap deflection. This might help determine the foil area required for take off at 15-20 mph. -- Bill Buckley (wbuckley@erols.com) [*This document is included in the Advanced Marine Vehicle (AMV) CD-ROM. See <http://www.foils.org/ihspubs.htm> for instructions on how to order - Editor*]

Hydrofoil Conversion, Need Vessel Recommendation

[2 Jun 01] I have searched as many sites as I can find, but have not really found what I am looking for... a hydrofoil for 10-15 persons I would guess. My desire is approximately 30 feet long by 9 or 10 feet wide. My only purpose is to use it as a pleasure craft like that of a Cabin Cruiser boat. I would like to buy one like this, but am more than willing to convert one to suit my desire. The nearest match to what I have been looking for is the AQUAVIT, but it does look smaller than I want. Do you know where I should start looking to find a craft with the dimensions and/or purpose that I seek? -- John Turnbull (John.Turnbull@abbott.com) phone: 847-937-1320 work; 847-828-0096 home

Responses...

[2 Jun 01] There are various resources on our website that may be of help to you:

- Previous correspondence about such vessels is posted at: <http://www.foils.org/buyferry.htm>
- Most recent offers to sell and requests to buy are on the announcements page at <http://www.foils.org/announce.htm>
- The links page includes some brokers who frequently have used hydrofoils for sale: <http://www.foils.org/linksout.htm>
- Photos of different types of hydrofoils are in our photo gallery: <http://www.foils.org/gallery/>
- If you are interested in converting a regular planing hull craft, take a look at Harry Larsen's site to see what is involved, including parts breakout and detailed estimated cost: <http://mysite.verizon.net/res6pe7p/index.htm>
- As to Aquavion products, I have posted various test reports, sales brochures, etc. Due to the files sizes, I have put these onto Freedrive.com. If you want to access them, use the following link to go to Freedrive and sign up for a free account. By using the link, IHS's folder will be visible and accessible from your free account. Here is the link: <http://www.freedrive.com/ASP/PostFolderShortcut.asp?fsc=27997828> Also, feel free to contact Vik Poremskis (email: viktor_por@yahoo.com.au), who provided this information to us and who personally has an Aquavit 10P.

As far as a source of different types of hydrofoils that have been designed and manufactured over the years, the best reference is old editions of *Jane's Surface Skimmers* dating back at least to 1968 and updated every two years at first, then every year. You may find copies in libraries, and

occasionally old copies go up for sale at <http://www.eBay.com>. You should feel free to contact any of the people by email who have posted messages on the IHS site and whose comments are of interest to you. In that event, please include webmaster@foils.org as a "copy to" addressee, and inform me of any bad email addresses that you may encounter so I can endeavor to update them (as time passes, people tend to change email addresses). Please keep us informed as to your progress; if you do a restoration, we would like to have photos and lessons learned for our newsletter and website. It is quite possible that the membership could be of help to you with specific technical questions that may arise while converting your craft. -- Barney C. Black (Please reply via the [BBS](#))

[10 Jul 01] Unistel Technologies (www.sun.ac.za/kie or www.unistel.com) offers a wide range of hydrofoil designs as retrofits to existing catamarans (hybrid systems). Feel free to contact me to put you in contact with the right persons, or clients of Unistel who have retrofitted the foils to their crafts. -- Gerard Verhoef (gv@adm.sun.ac.za)

Adding Foils To a Ski Boat

[18 Feb 00] I was reading an internet article named "the Upright Hydrofoil Kits". I was wondering if such kits were available today. I am interested in putting hydrofoils on my 1978 16' Chrysler trihull ski boat. Any info would be greatly appreciated. -- Rick Bailes (bailesrs@wirefire.com)

Response...

[18 Feb 00, updated 30 Mar 01] There are no kits offered today that I know of. [Tom Lang](#), the author of [the article you read](#), may be willing to offer answers to specific questions. I have a [1965 brochure from Supramar](#) offering a foil kit, but have no info on the kit itself. Certainly it is no longer available today, if in fact it ever was a reality. Grumman offered the Sea Wings hydrofoil kit, but that is no longer available either. Also, there were some articles several years ago in how-to magazines about adding foils. See the [IHS page on popular magazines](#). You can find copies of these magazines at certain antique stores, or you can search for them on www.ebay.com periodically... sooner or later everything turns up on eBay. The foils treated in the magazine articles are not exactly what I would call high performance. -- Barney C. Black (Please reply via the [BBS](#))

Sea Wing Hydrofoil Kit Questions

[7 Oct 00] I have a Grumman SEA WINGS kit, and a small tin (aluminum) boat which is suitable for installing the kit on. Still need a motor, finding a long shaft OB of the proper horsepower CHEAP isn't easy. Does anyone have more information, experience with the SEA WINGS kit? Can I safely exceed the rated power/speed of the kit? i.e., 55 HP. Anyone done one of these installations? I know it's been a long time since these were manufactured, but the kit is complete, and I have a copy of the installation manual. -- Peter Jacobs (pjjacobs@itol.com)

Response...

[9 Oct 00] Sorry, but I have no experience with the Sea Wings kit. As far as I know, it is a very good hydrofoil design. I would guess that these kits are very rare; so whether you use it or not, you might consider eventually offering it to some maritime museum. I wonder if relatives of Bill Carl, who developed the kit, could be of help. Also, I cannot answer the 55 hp limit question, except to say that I mounted a 65hp Mercury long shaft outboard on my Up-Right kit, and reached 46 mph without problems. Cavitation can be a problem at speeds above 45 or 50 mph; however, cavitation depends on the particular hydrofoil cross section used, and I am unfamiliar with the Sea Wings foil sections. -- Tom Lang (tglang@adelphia.net)

Interesting New Member

[22 Jul 00] Enclosed please find my check for membership in your fine society. I go back to the late 1950s for my first hydrofoil ride on a 16 foot Challenger outboard boat with a 35 hp Evinrude engine. I am a contemporary of John Gill and Company, and had the pleasure of driving their "Whisker" foil boat with Jim Wynne and Walt Walters. -- Allan L. Brown [no email address provided] 1045 N.E. 119 STREET; NORTH MIAMI FL., 33161; phones: 305- 681-7893 (office); 305- 685 -1457 (fax)

Adding Foils to 11' Whaler With Outboard Engine

[7 Jul 00] I want to put foils on my 11 ft Boston Whaler with a 25hp outboard so I can handle small waves better at cruise....how can I find such foils hopefully already made so all I have to do is mount them...or....find out if someone has already done this ...thanks. -- Matt (mattmccool@earthlink.net)

Pivoting Hydrofoils and Powered Planing Craft

[23 Jun 00, updated 28 Oct 00] The concept came about from watching my son and his friends windsurf on the Lake of Two Mountains at Hudson, Quebec. The stern of their sailboards dragged deeply in the water creating a lot of drag and I thought, "there must be a solution to that". Some years later, this thought resulted in U.S. Patent No. 4,811,674 which covers the pivoting foil concept for drag reduction of sailboards and other craft including powered planing craft. The following is a brief description of this new foil concept for drag reduction as it applies to powered planing craft:

The reduced drag of the planing craft's hull will result in its increased acceleration to higher maximum speed and more efficient operation at all speeds which translates into greater fuel economy and an extended operating range. The pivoting foils, much smaller than the foils on conventional hydrofoil craft, are installed directly on the hull

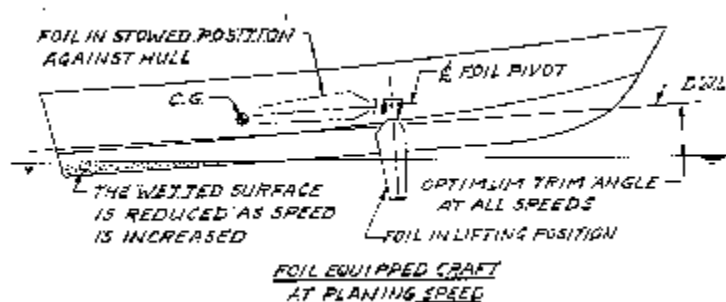

without any intervening support structure between the foils and the hull. The pivoting feature has a unique and important role in the foils' operation. By allowing the foils to pivot downward from a lifting position to a non-lifting position, the pivoting feature prevents the foils from generating the negative lift which would otherwise occur under some conditions. These small foils, by generating a lifting force that interacts hydrodynamically with the hull in a specific manner, create a synergistic effect that makes both the hull and the foils more efficient than if they were functioning separately. This synergistic action is the key to the effectiveness of this concept. The small size of the foils allows them to be rotated to a stowed or inactive position alongside the hull for operation in shallow water and for convenience in docking. The efficiency gained by using these foils will vary from craft to craft depending on a number of variable factors. However, it can be said that substantial hull drag reductions would be readily achievable - up to 50 percent in some cases. It is expected that the lower fuel consumption provided by the foils would over the life span of the craft more than pay back the original cost of the foils and thus make the foil installation a profitable investment. The rate of saving would increase over time due to the inevitable increase in the price of fuel. This is seen as an important factor in

evaluating the foil concept. The reduction of environmental pollution due to lower fuel consumption is also seen as being of importance today and of even greater importance in the future. We see a bright future for the pivoting foil concept and high financial returns for those participating in its development to a market-ready state.

Individuals or companies interested in additional information on this new concept and the possibility of investing in the development of a prototype are invited to contact us. Jim Stewart, Motion Design Creations Inc.
(jbstwrtn46.com)

Structural Impact of Adding Foils to a Motor Yacht

[29 Mar 00] If you were to somehow succeed against all odds, hydrodynamic and otherwise, in converting the typical aluminum motor yacht in the 50' to 90' range from a 10 to 15 knot vessel to a 35 to 50 knot vessel by re-powering and adding foils, would it be likely that the hull could withstand the impact from the occasional large wave? Stated another way, is it correct to presume that faster speeds demand stronger hulls, and that it is unlikely that an aluminum hull designed for lower speeds could withstand the stress at higher speeds? -- David
(ny@mindspring.com)

Responses...

[29 Mar 00] Both displacement (10-15 knots) and planing (35-50 knots) craft are designed for hydrodynamic and wave bending loads. Planing craft must additionally be designed for bottom slamming loads (and bending stresses resulting from the slams). As you note, a hydrofoil craft will experience "occasional" slams. The structure of the 10-15 knot craft would have to be analyzed for these added loads probably resulting in a requirement for strengthening - both for local slamming loads and the associated longitudinal bending. -- Ken Spaulding
(secretary@foils.org)

[29 Mar 00] According to classification society structural design rules (such as ABS, Lloyd's), the slamming pressure of a fast craft is proportional to V^2 . It will be subject to damage for a hull designed for 10-15 knots when it is re-powered to 35-50 knots. -- Weimin Hu
(whu@mapcorp.com)

[29 Mar 00] The answer to your question is: not likely because the local wave impact pressures would tend to increase with the square of the vessel speed, i.e. $(50/15)^2 = 11.1$. This problem is bad enough, but the hull would have to be extensively reinforced at the foil attachment points and a more powerful engine(s) might have to be added to go foilborne. In any case the propeller shaft(s) would have to be lengthened for the propellers to remain submerged while foilborne. On a more positive note, in 1954 a Chris Craft cabin cruiser L= 28.5 ft., B= 9 ft., displ.= about 5 tons and equipped with 235 hp. marine engine was modified to add foils. This craft, named [SEA LEGS](#), flew successfully with a vacuum tube autopilot and sonic height sensor. -- Bill Buckley (wbuckley@erols.com)

[29 Mar 00] I'm not a structures expert, but I think the answer is no. The loads will go up as the square of the speed, and if this is an aluminum hull with lower structural modulus than steel, deformation and hull failure would be expected by speed increases that are 3 to 4 times the design speed. I doubt that the hull could be modified sufficiently with additional intermediate stiffeners, since there would be potential mismatch between skin thicknesses and stresses at the stiffener/shell weldments. -- Mark Bebar (bebar@foils.org)

[29 Mar 00] This would be a very difficult generalization to make since there are widely varying design approaches for a 15 knot 50-foot motor yacht. In general, we would expect to use design pressures of about 40 psi on the forward hull of a hydrofoil where wave slamming could occur. This is higher than the normal design pressures for a traditional displacement vessel. -- Mark Rice (mrice@mapcorp.com)

[11 Jun 00] The premise of the question is wrong. Yachts are built of aluminum to be light so that they, with sufficient power, will go fast. If the premise is changed to a yacht with a planing speed, 20 + knots, and if the conversion maintains the same power, then a conversion to a hydrofoil is more feasible. The hull form will be about right, usually deep V. By maintaining the same power the hydrofoil speed will not be dramatically faster and the slamming load increase a small rather than large factor. Further, the slamming, with the proper ride pitch, will impact the finer bow section rather than at a mid section. In the case of [SEA LEGS](#) and [TALARIA III](#) perhaps the most significant (only) modification beyond the hydrofoils was in their propulsion systems. *SEA LEGS* utilized a very long V drive. *TALARIA* extended a Volvo outdrive. Although I have not personally inspected *SEA LEGS*, from the drawings I have seen, I am not aware of any significant hull modifications other than at the strut attachment points. *TALARIA* has no hull modifications other than at attachment points, For both of these boats and perhaps for larger planing craft the structural requirements of a planing design dominated the loads that would be experienced by a hydrofoil modification. By changing the craft to be converted from a slow aluminum craft, (that largely do not exist), to a fast aluminum craft (that do exist), a hydrofoil conversion, although still not easy, is at least possible. In some cases, historically, even successful. -- Harry Larsen (talaria@foils.org)

Foils For 50' Cat

[19 Jan 00] I am planning the construction of a trawler style catamaran early this year. It will be 50 feet, displacement approximately 16 tons. I would be very interested in the incorporation of hydrofoils on this boat. I am interested in economy, not speed, as this will be a live-aboard boat.

I didn't find on your website any information specific to this style boat. Any help would be appreciated. -- Bob Boyle ([sojern @ netscape.net](mailto:sojern@netscape.net))

Independent Assessment of TALARIA III

[7 Jan 99] When I was last in Seattle I had the pleasure of not only meeting Harry Larsen but actually getting to ride in his hydrofoil [TALARIA III](#). This is the first time I have been able to ride one foilborne and I can tell you it is amazing! When she is sitting in the water it is not obvious that she is very different from any other cabin cruiser. The fully submerged foil system is controlled with a custom build analog computer using an inclinometer (pendulum type device) for roll control and a front mounted ski type of mechanical height control. Mr. Larsen tells me it was an important design criteria not to use expensive aerospace equipment like gyros. Propulsion is provided by an extended I.O. The system is fully retractable and appropriate measures have been taken to minimize damage from drift strikes. Exiting the harbor was much like any other at a slow pace to minimize wake, advancing the throttle, the small block Chevy revs smoothly and then becomes slightly louder as the exhaust rises out of the water. The change from hull to foil is not felt so much as a lift sensation but more like some one let go a trailing line that was towing an anchor. The motor revs up with the reduced drag and the boat speed increases. Looking aft, the wake nearly disappears. You feel a change in the ride immediately as the waves seem to vanish. There is still some feeling but it is as though you just went from riding in a buckboard wagon to a Caddy. The slamming of waves normal to crossing the wake (we went looking) was completely gone. The real difference was when he let me drive. As the craft became foilborne the response to the helm changed from the feeling of driving a boat to that of flying an aircraft. Albeit a small aircraft that had rudder input tied to the ailerons as a few do but it I found the similarities amazing. Turning the helm banked the craft and directed the boat into a turn with a minimal of lateral acceleration. A very tight turn was possible without stalling. I was most amazed at the stability and feel of control, after becoming comfortable there is no doubt that you could cruise at speed right through most traffic with confidence which Mr. Larsen demonstrated at he took her back into the harbor. He tells me that while it is safe and there is less wake than at all but idle speed hull borne the problem with such a maneuver is that it will scare the wits out of others in the harbor to see this big cabin cruiser moving at 25 knots so close. It would result in someone immediately calling the coast guard or harbor master! Fortunately for us this was a cool fall day and there was no one else around. This would be the perfect answer to big lakes like The Lake of the Ozarks that are nearly unbearable due to the rough conditions from so much traffic. I simply find it ridiculous that there are so few hydrofoils out there. This is a gold mine I swear. For no more than it would cost to have a conversion done, after riding Mr. Larsen's boat there is no way I would spend the kind of money a cruiser of that size cost without having it fit with foils! -- Elliot S. James (esjames@cvalley.net)

Response...

[6 Mar 00] I have added more pictures of *TALARIA III* to [my web site](#). Also a parts list with approximate cost. Specifically it is a "complete" parts list with all sub assemblies. The cost is the cost of the part and all its sub parts - an indented parts list. As such, one can see the cost of any sub part, e.g. electronic, hydraulics, structure, or element of that sub part. Each part's cost includes all of its sub part costs but not its assembly labor cost on the boat. The "System" cost is

the sum of the cost for all hydrofoil-related parts in *TALARIA III*. For example, the aft foil cost is the cost to cast the foil and the labor cost to machine it. It is intended to be an estimate of what someone would pay to have that part made, ready to install on a boat. It may be useful to builders for their better understanding of the cost of the various subsystems. -- Harry Larsen (talaria@foils.org)

Adding Foils To a Motor-Driven Pontoon Boat

[12 Sep 99] I would like information, plans or a kit for the following project I want to undertake. I want to build a pontoon boat hydrofoil combination. The boat will be 12' to 18' long, made to carry 2 to 4 people with gear. A rough estimate of the payload is 400 to 800 lbs. It will be for recreational use and powered by an outboard motor. As far as speed is concerned, I'm looking for around 40 mph or so. I plan on using aluminum sheeting for the pontoons, tubing for the platform structure and nylon webbing for the deck similar to the Hobies. Everything will be done to minimize weight as I would like to use as small a power plant as possible. Building the pontoon boat will be no problem, but when it comes to the foils...I'm pretty clueless. I know I want surface piercing as they are inherently stable. I want the foils to be retractable for beaching, or at least be able to remove a few pins for their removal. It seems like 4 independent foils (one at each corner) would be a good place to start for that capability. Here are just a few of the questions I have at this time:

1. Is there an "airfoil" cross section that you would recommend for this?
2. Is there any available pre-made anything for this?
3. What kind of configuration would you recommend (the frontal view angles, dimensions, etc.)?
4. Is there anyone who could provide plans specific (or even general) to my application?
5. Would it be possible for a sheet metal shop to bend the correct airfoils and weld a bead on the leading and trailing edge to "create" the foils I'd need?
6. Approximately what engine horsepower would I need to accomplish this?

As you can see, I'm undecided on the actual size, etc of this boat as I'm not even sure what would be possible. An 18' version would be nice, but not if it needs 300 hp to operate. My goal is for a small day transport that could be used to sunbathe on, fish from, even camp on overnight. (I thought about being able to attach a small 4 person tent on the deck for inclement weather). It should be able to operate in 2' to 3' waves. Some of the information I've received has been rather technical in nature. I'm an average person with a good mechanical aptitude. "Reynolds numbers" mean nothing to me. I would appreciate practical advice for the layman if possible. I really need help on this as there seems to be no real source for anything ready made. Apparently, hydrofoils are still in the pioneering stage(?). -- Jeff Mikkelsen (mikki@softcom.net)

Response...

[12 Sep 99, updated 30 Sep 00] There is nothing ready-made for what you want to do. IHS has been contacted a couple of times in the past few years by people who had a similar project in mind, but we never heard if anyone actually carried through. You should start by reading [Tom Lang's article](#). There was another add-on hydrofoil kit offered by Baker Mfg that was a

commercial spin off of Baker's work for the Office of Naval Research, but I don't have any information on it. I will forward a copy of your inquiry to some of our engineer/designer members in the hopes that someone will comment on at least some of your questions. If you could get a copy of David Keiper's book *Hydrofoil Voyager*, it would help you even though his [WILLIWAU](#) was a sailing trimaran. He had a system of retractable, surface-piercing foils, and others have devised various ways of attaching foils to sailing catamarans and trimarans... this may be your best avenue of research. After Dave died, IHS reprinted his recent files on the subject of foil kits that he was preparing sell for catamarans; these may be of interest to you (details at <http://www.foils.org/ihspubs.htm>) Finally, I will post your inquiry on our website to see what responses that may bring. Good luck to you! -- Barney C. Black (Please reply via the [BBS](#))

PS - As to whether hydrofoils are still in the pioneering stage, you can get a sample of what pioneers have done at [our webpage on this subject](#). Pull this project off successfully, and maybe you can join their ranks!

2nd Response...

[14 Sep 99] Design guidance and a review of some of the sailing hydrofoil craft that had been built by the early 1970s are in the following book which is in an easy to read format: [Hydrofoil Sailing](#) by Alan J. Alexander, James L. Grogono and Donald J. Nigg; Published in Great Britain in 1972 by Juanita Kalerghi, ISBN 0 903238 00 4. One of the authors, James Grogono, designed and built a very neat surface-piercing hydrofoil based on a Tornado catamaran hull. From memory, this had a pair of inclined surface piercing hydrofoils forward supporting the greater portion of the weight of the boat. One was attached to the outboard side of each pontoon hull. I believe the aft foils were fully submerged and connected to the base of the rudders which were attached to the transom of each hull. In any case, the book describes the evolution of that sail boat design (named *ICARUS*) in some detail, and it is the nearest I can come up with to an 18' powered catamaran. By the way, I had a laugh when I read your belief that hydrofoils are in the pioneering stage... more like twilight if we don't do something about it! - Martin Grimm (seaflyte@alphalink.com.au)

Cabin Cruiser Foil Conversion

[29 May 99] Does anyone market a foil kit for cabin cruisers? Or is this impractical, considering the weight and HP of a typical cabin cruiser? -- (kris@cnet.com)

Response...

[29 May 99, updated 19 Mar 00] The one person I know of who has done this is Harry Larsen, a Boeing employee, who modified his Bayliner named *TALARIA III*. He is willing to correspond with others interested in doing the same. [Click Here](#) for photos, specs, contact info, cost estimates, etc. There is no kit marketed for doing this that I know of. -- Barney C. Black (Please reply via the [BBS](#))

Foils for Powershuttle 40

[15 Dec 98] I have some general questions about power boat foils: Since I'm mainly a power boater the last few years, a recent power cat design (Powershuttle 40 by Shuttleworth) caught my eye. It's a displacement type hull using twin 90 hp. 4 cycle outboards for a speed of about 20 knots. Would a similar size and weight boat using foils be able to get up on its foils using these outboard motors? Does a foiler have to plane first to achieve foiler posture? These questions assume of some method to adjust the motor height for foiling. -- Jim Montgomery
[\[AMontgo830@aol.com\]](mailto:AMontgo830@aol.com)

Response...

[16 Dec 98] Hydrofoils can be designed for nearly any boat weight for a takeoff speed of around 15 or 16 mph. Therefore, if a displacement boat without foils can reach 20 knots, then hydrofoils can be designed to lift it out of the water. The speed should increase at least 10 mph. Some of the boats shown in [my IHS article](#) could not plane when heavily loaded; but, when outfitted with hydrofoils, they would first plane, and then rise out of the water. However, boats do not have to plane to rise up on hydrofoils. -- Tom Lang [\[tglang@adelphia.net\]](mailto:tglang@adelphia.net)

David Keiper on Powerboat Foils...

[24 Aug 98 -- *Following draft email was found on David A. Keiper's hard drive. It was composed on 23 June, the day he started feeling ill. Dave died on 27 Jun 98*] Because there is some interest in powerboat hydrofoils in the IHS, I thought I should spell out some of the details of such installations. At present we can only outfit powerboats of about 1000 to 1200 pounds all-up weight, using our 3"-chord hydrofoils. About powerboat foils: we outfitted several small powerboats with foils back in the 1970s. To our knowledge, they were all successful. With our larger foils, of 3" chord, we can outfit somewhat larger craft. A powerboat of 1000 pounds +/- all-up weight would be suitable (about the same as for sailing catamarans). We figure a lower take-off speed on the powerboats, because their hulls are rather draggy compared to cats. On the powerboats, both ladder foils are fully lifting, so that results in a lower take-off speed than with sailing catamarans. Only one stern stabilizer fin is needed. Best if it is located just above the prop, to help keep the prop in the water all the time. Many previous powerboat foil designs were only good in fairly flat water, and their foils could never be used on sailboats. The ladder foils for a sailboat must perform well in rough water, and they are excellent on powerboats in rough water. The main foils on a powerboat should be located around the center of gravity of the boat. Sailboat main foils are located a bit further forward, because of the forward sail pitching moments, and lack of engine thrust that would tend to bring the bow up. If you are figuring a top speed of 40 knots, our standard foil kit should do very well for you. It uses the Clark-Y lifter section, which may suffer cavitation problems around that speed. The Clark-Y is an excellent foil section for multihull sailing hydrofoils, which are mainly sailing in the 10 to 35 knot range. Of course, it is probably also an optimum foil section for power boaters operating on rough waters, such as found on San Francisco Bay. If you are seeking to get to 50 knots, we would want to modify the main foils slightly, installing a 3"-chord NACA 16-510 lifter in the lowest rung of the ladder foil. (Our standard strut section is NACA 16-008, which is good for 60 knots.) At this point, we are not making the capital outlay for the 16-510 lifter extrusion, but it is likely in the next year or so, when sailors want to try breaking sailing-speed records, or when several power boaters approach us for foils. It would be easy to retrofit the high-speed foil on the foil units. We

will be doing our foil tests on an 18-ft Hobie Cat in October. I don't expect much testing to be necessary since we thoroughly tested this system twenty years ago, using 2"-chord foils on a one-man Hobie-14. We also successfully outfitted several lightweight power dinghies with foils. . . . We will have 3"-chord foils now for the somewhat bigger cats, carrying 2 or more crew. We expect to have our 3"-chord aluminum hydrofoil extrusions at the beginning of October '97, and shortly thereafter will be testing in our fall winds, probably on Kentucky Lake. I expect we'll be shipping foil kits in November. Yes, that was me in aluminum dinghy, but it was Auckland Harbor, NZ. The company interested in foils was too cheap to put a shaft extension on the engine, so I had to sit fairly far aft to keep the prop in the water. It was fall, and the water was getting cold. Sitting aft unloaded the main foils, which reduced lateral stability. Stern foil had no lateral stability. Made a turn, and surprise, I found myself in that cold water. -- [David A. Keiper](#)

Foils For a 17 ft. Ski Boat

[19 Mar 98] I have a 17' ski boat with a 115 hp Mercruiser I/O. Can it be retrofitted with foils and if so how do I do it or who does this kind of thing. It will go about 45 mph at wide open throttle of 4500 rpm but ride is rough when the wind brings up swells on a local lake. 2 foot waves make ride miserable going across the lake or for a long ride. It is a deep vee and rides well when trimmed up in moderate clean water, give some waves and it is rough. -- Corrie Cammack (corriec@cybertron.com)

Response...

[26 Sep 98] One of the major benefits of hydrofoils is a smooth ride in rough water. There are a few hobbyists around adding foils to speedboats, but none that I know of available off the shelf as a bolt-on commercial product. The Winter 97/98 IHS Newsletter has a [long article](#) by [Tom Lang](#) with many design tips on the subject of adding foils to small motorboats. He did extensive experimenting in the 1950s and ultimately perfected an add-on kit design that was manufactured and marketed by the Upright Scaffolding Corps (the kit was not a huge commercial success and was discontinued). If anyone thinks there is a better market today, you may be able to get the rights to manufacture his design. -- Barney C. Black (Please reply via the [BBS](#))

Response...

[23 Mar 98] IHS member Ken Grina (grina002@tc.umn.edu), who used to work for Boeing Vertol and I knew when I worked there over 25 years ago, has DONE what Corrie wants to do. Corrie, You may want to write to Ken and get some info. -- John Meyer (jmeyer@erols.com)

HydroSail Interested in Power Boats, Too

[19 Mar 98] I work with Sam Bradfield at HydroSail Inc. We are sailing hydrofoil designers (although we must admit to putting foils on power boats too). We have recently started a [web page](#) which I thought the membership might like to know about. It has a few photos, and I will continue to add info about our designs and work. -- Mike McGarry, HydroSail Inc., phone: (407)723-0733, (hydrosail@aol.com)

Foil Revolution?

[2 Jan 98, updated 3 Nov 02] Looking to your organization to get a set of L or T foils for power trimaran. Lift capacity, 600 lbs @ 21 knots with minimum drag. Foils should be 4 feet +or- and can be aluminum or glass construction. Need maximum strength, weight is not so critical. Can pay up to \$2,500 for a set that will last 26,000 miles. E-mail: shidler@revolution98.com. Revolution98 is an Around The World powerboat project that will attempt to break the existing record of 83 days set in 1960 by the US nuclear submarine *TRITON*. Official Start is from Miami FL on 28 Feb 98. Visit our website <http://www.revolution98.com> for a look at our project. -- Jack Tinsley (tinsley@revolution98.com) [*Webmaster's note: the revolution98 website has dropped off the net. The attempt to break the 83 day record was terminated early, thanks to a hidden uncharted reef off the coast of Nicaragua.*]

[6 Aug 97] I own a ski boat that I would like to fit with foils. My boat specs are: Direct drive prop, Mid engine mount, 20 foot length, 90 inch beam, 2500 lbs., 44 mph top speed, 280 horsepower; hull style is deep V bow to 10 degree V back to transom. I am desperately trying to modify the shape of the wake behind the with a single trim plate of various sizes and shapes using hydraulics to adjust the angle. But all I really achieve is pushing down the bow and creating harder wakes from all the extra hull in the water. I discovered by mounting the plate on 4" struts below the hull surface I am getting a more suitable wake. I don't really want to raise my hull completely out of the water , but if I could get my stern from 8" below waterline to a couple inches below waterline I think I might accomplish my goals. Also I do have a mounting location for a forward foil if recommended . I am a metal fabricator and welder so I am able to fabricate the foils. Could you please help me with the specs. on the foil such as the surface area needed and what the cross section of a foil should be shaped like? Currently the flat plate is 39"x11". -- Dean Yaeger (dayaeger@aol.com).

<[Back to Top of Page](#)> <[Go To IHS Main Page](#)> <[Return to Posted Messages Bulletin Board](#)>
