

FIG. 1

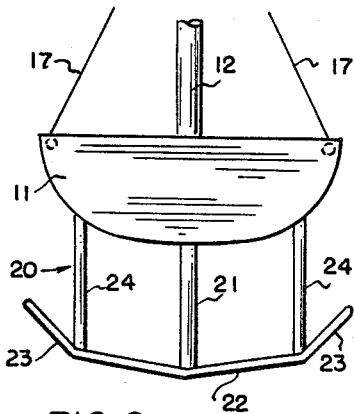
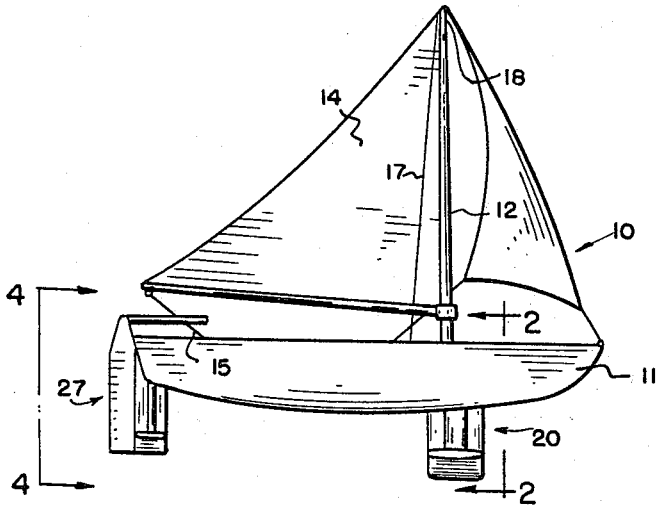

FIG. 2

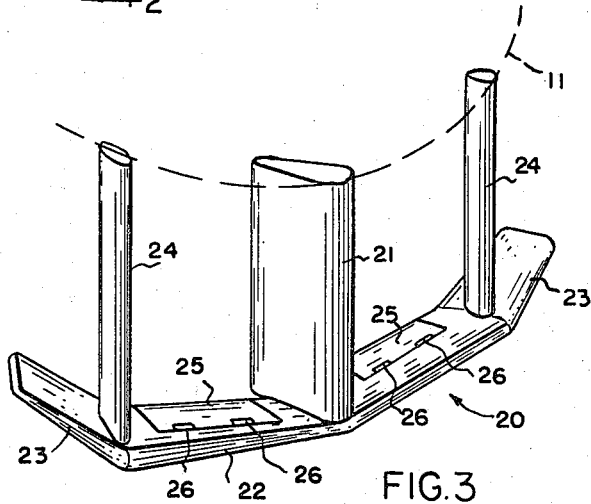

FIG. 3

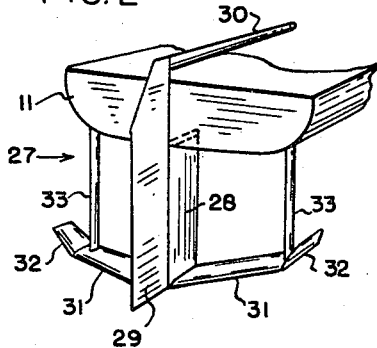

FIG. 4

INVENTOR
AMIRAM STEINBERG

BY *Sullen, Roman, & Cantor*

ATTORNEYS

FIG. 5

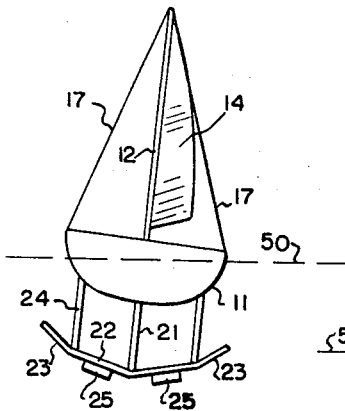
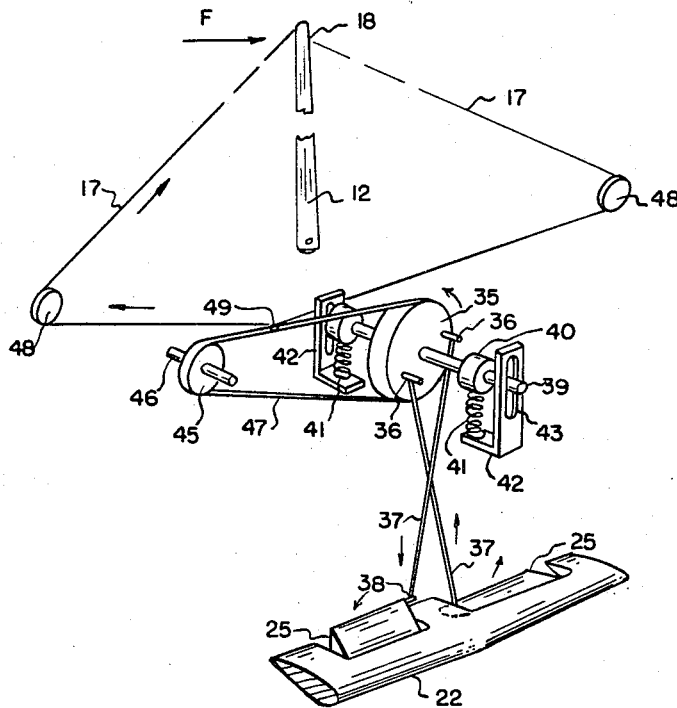

FIG. 6

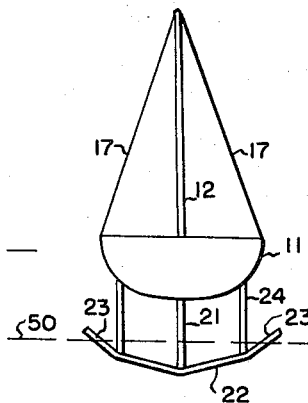

FIG. 7

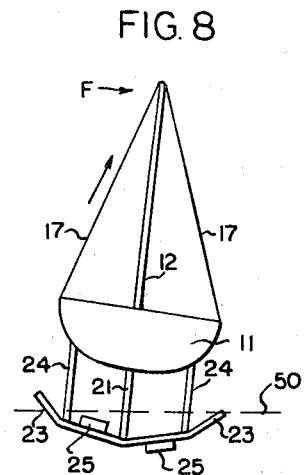

FIG. 8

INVENTOR
AMIRAM STEINBERG

BY *Gallen, Roman, & Cantor*

ATTORNEYS

1

3,373,710

HYDROFOIL BOAT

Amiram Steinberg, Ann Arbor, Mich.

(8 Vitkin St., Tel Aviv, Israel)

Filed June 1, 1966, Ser. No. 554,372

5 Claims. (Cl. 114-39)

ABSTRACT OF THE DISCLOSURE

The hydrofoils of a hydrofoil-equipped sailboat are provided with a pair of ailerons which are linkage-controlled directly from the mast shrouds. Wind forces acting upon the mainsail induce a tension in the windward shroud, which tension acts through a linkage to cause the windward aileron to produce a negative lift and the leeward foil to produce greater positive lift, thus stabilizing the boat.

This invention relates to a hydrofoil boat, and more particularly to a sailboat equipped with a hydrofoil having automatically controlled stabilizing and lift ailerons.

In the past, efforts have been made to equip sailboats and other small craft with hydrofoils which function to support the hull of the boat above water in order to reduce resistance and thereby substantially increase speed. In the case of sailboats, the transverse wind forces on the rigging, as well as the weight of the mast and sail, necessitate some sort of counterbalancing means to prevent the boat from tipping over particularly when sailing on its hydrofoil.

In order to provide such stability, hydrofoil attempts utilized extremely wide bases for support as well as various complicated mechanisms to provide stability in addition to widening the base of support. However to date, such type of hydrofoil sailboats have been impractical for many reasons, including lack of stability and insufficient maneuverability characteristics, and also size of foils needed, etc.

Hence, it is an object of this invention to provide a sailboat having hydrofoils which include ailerons which operate automatically in response to pressure on the mast, that is, such as wind pressure on the sail transmitted to the mast, to compensate for and counterbalance such pressure and stabilize the boat under all operating conditions.

A further object of this invention is to provide a hydrofoil sailboat which utilizes at least two ailerons constructed to automatically function as lift flaps before and at times during take-off of the hull from the water and thereafter to function as stabilizers to automatically counterbalance and stabilize the boat against wind forces upon the sail and against centrifugal forces during sharp turns, etc.

Yet, another object of this invention is to provide a hydrofoil sailboat having a relatively inexpensive and simple automatic control and construction for automatically compensating for wind pressures for stabilizing the boat and for providing additional lift during take-off from the water.

These and other objects and advantages will become apparent upon reading the following description of which the attached drawings form a part.

In these drawings:

FIG. 1 is an elevational view of the sailboat herein.

FIG. 2 is a cross-sectional view, enlarged, of a portion of the sailboat taken in the direction of arrows 2-2' of FIG. 1.

FIG. 3 is an enlarged perspective view of the hydrofoil construction, and,

FIG. 4 is a perspective view of the rear of the sailboat showing the rear supporting hydrofoil and rudder.

2

FIG. 5 is an enlarged schematic view showing the control mechanism for operating the ailerons.

FIGS. 6, 7 and 8 show the sailboat in three different sailing conditions and are schematic views as if taken from the bow direction.

Referring to the drawings, and particularly FIG. 1, the sailboat 10 is formed of a hull 11, with a mast 12 having a swingable boom 13 which together carry the main sail 14. As is conventional, the main sail is controlled by the conventional main sheet 15.

The usual jib 16 is shown mounted upon the forestay as is conventionally found on sloop rigged boats of the Marconi type rigging.

In addition, shrouds 17 are connected at their upper ends 18 to the mast, with the mounting of the lower ends of the shrouds to be described below.

The foregoing description describes a conventional sailboat in general constructions.

The invention herein relates to the construction of the hydrofoil, which as shown in FIG. 3 is generally designated as 20. Such hydrofoil includes a vertical center support 21 at whose lower end the hydrofoil 22 is secured. Upwardly bent stabilizer foils 23 extend outwardly and upwardly from the opposite ends of the hydrofoil 22 and side supports 24 support the sides of the hydrofoil and interconnect them with the side portions of the hull. As can be seen, the hydrofoil is relatively narrow, preferably being not much wider than the beam of the boat, and is located approximately beneath the mast.

A pair of ailerons 25 are hingedly connected at 26 to the hydrofoil 22.

Referring to FIG. 4, a similar hydrofoil may be provided at the aft or stern end of the boat, this being generally designated as 27 and comprising a center support 28 to which the rudder 29 is hingedly connected with the tiller 30 being above the deck of the boat for control. The hydrofoil 31 includes the stabilizer foils 32 at its opposite ends and side supports 33 connecting the ends of the hydrofoil to the sides of the hull.

Ailerons may be included in this construction where desired, and where necessary due to the size of the boat, but for illustrative purposes no reference to such ailerons is shown in the drawings in FIG. 4.

The two ailerons 25 (see FIG. 5) are controlled for joint movement upwardly and downwardly, particularly downwardly, to increase lift when needed as well as to operate independently, but oppositely, with one going up and the other going down, to provide transverse stabilization when the hull is out of the water. The control means for operating the stabilizers include a control drum 35 having fastener points 36 secured on one face thereof to which are connected stiff control rods 37 whose lower ends are connected by pins 38 to each of the ailerons 25.

The control drum 35 is rotatably mounted upon shaft 39 supported by bearings 40 which in turn are supported by springs 41 having their lower edges joined to brackets 42. The brackets which are fixed to the hull of the boat are provided with guide slots 43 for guiding the ends of the shaft 39 for upward and downward movement only, against the resistance of the springs 41, which normally pull the shaft downwardly.

A pulley 45 rotatably mounted upon a shaft 46, secured to the hull of the boat (by mountings not shown) is connected to the control drum 35 by means of a belt 47. Preferably, the pulley as well as the control drum is provided with teeth, like sprockets, and the belt 47 is also toothed for more positive drive.

The lower ends of the shrouds 17 pass about pulleys 48 secured at opposite sides of the hull and then extend downwardly and are connected together at 49 to a point on the belt 47.

3

In operation, referring to FIG. 5, the two control drum fastener points 36 are horizontally aligned and the springs 41 pull the control drum shaft 39 downwardly to thereby push the stiff rods 37 downwardly, which in turn forces the two ailerons simultaneously downwardly. In that position, as shown in FIG. 6, the hull of the boat is riding in the water and the two ailerons, well beneath the boat within the water, now increase lift to assist in the take off of the hull from the water as the speed of the boat increases.

As the boat picks up speed and begins to ride upon the foils, as schematically shown for example in FIG. 7, the water pressure against the ailerons force them upwardly towards complete alignment with the hydrofoil 22 and as these ailerons move upwardly, they in turn force the rods 37 upwardly to thus force the control drum 35 with its shaft 39 upwardly.

Now, with the boat riding upon its hydrofoil the force of the wind upon the sail will cause the mast 27 to shift away from the wind under the force. The movement of the mast may be accomplished by mounting the mast pivotally at its lower end for such movement or the mast may be slightly flexible so that it bends as many masts commonly do. As the top of the mast moves away from center, it exerts a pull on the shroud on the windward side while the shroud 17 on the leeward side tends to become slackened. (See the arrows in FIG. 5 and also FIG. 8.)

The difference in tension in the two shrouds, that is, the pull on the windward shroud as compared with the slackening on the leeward shroud, causes the shrouds to move and thereby causes the belt 49 to move with the shroud to which it is connected. This rotates the control drum 35 to force one of the rods 37 downwardly, while pulling the other one upwardly, thereby lowering one aileron and raising the other a sufficient amount to compensate for the force on the shroud as shown in FIG. 8, wherein one aileron is up and the other downwardly, the ailerons now counterbalance the force of the wind to stabilize the boat and permit it to sail at high speed upon the hydrofoil.

As the force upon the mast, that is the wind force upon the sail increases, the ailerons will further move apart and as the force decreases, the ailerons will automatically move towards alignment with the hydrofoil. Hence, it can be seen that the ailerons automatically and instantaneously respond to the varying force upon the mast to stabilize the boat at all times, even under gusty conditions and the like.

Even while the hull is in the water, the ailerons can also oppositely act as well as be moved jointly downwardly, to stabilize the boat as well as at the same time increasing lift for take off.

The specific hydrofoil construction illustrated above may be modified into other hydrofoil forms, but the illustrated form seemed to be preferable for maximum stability for this type of craft, namely, a relatively small sailboat, while other hydrofoil forms may be desired for other size and shape boats, but utilizing the invention herein, namely, an aileron construction as described above.

Likewise, the means for controlling the ailerons may be varied somewhat within the scope of this invention, such as controlling the ailerons by connecting the main sheet, which controls the sail, to the control means as the means of transmitting the force upon the sail to the control drum. Alternatively, the mast may be mounted so that its lower end slides transversely or sideways and is also connected to the control drum to provide movement of the drum in response to movement of the lower end of the mast.

This invention may be further developed within the scope of the following claims. Accordingly, it is desired that the foregoing description be read as being merely

4

illustrative of an operative embodiment of this invention, and not in a strictly limited sense.

Having fully described an operative embodiment of this invention, I now claim:

1. A sailboat comprising a hull having a mast upon which a sail is secured, and a hydrofoil secured to and mounted beneath and transversely of said hull;

said hydrofoil including a pair of ailerons movably fastened thereto for upwardly and downwardly movement relative thereto, with one aileron extending from the center line of the hull and towards one side edge thereof and the other aileron extending between said center line and opposite side edge of the hull; control means for raising and lowering said ailerons and means connecting said control means to each of said ailerons;

said control means being movably mounted upon said hull and being movable in one direction to simultaneously raise one aileron and lower the other and movable in an opposite direction to reversely move said ailerons;

force transmitting means interconnecting the sail and said control means for moving said control means in response to the direction and amount of force applied to said sail, wherein said control means moves in response to such force to thereby move said ailerons in directions to counteract and counterbalance the force upon the sail;

said control means being movable upwardly and downwardly in addition to its aforementioned directions of movement, to thereby move both ailerons upwardly and downwardly simultaneously in addition to oppositely moving said ailerons, and resistance means normally holding the control means in a position for moving both ailerons simultaneously downwardly for holding the ailerons in a lift angle position before the hull leaves the water during sailing;

said resistant means being formed to become relatively inoperative upon a predetermined water pressure upon the ailerons to no longer hold the ailerons in a lift position beyond a predetermined speed as determined by water pressure.

2. A sailboat comprising a hull having a mast upon which a sail is secured, and a hydrofoil secured to and mounted beneath and transversely of said hull;

said hydrofoil including a pair of ailerons movably fastened thereto for upwardly and downwardly movement relative thereto, with one aileron extending from the center line of the hull and towards one side edge thereof and the other aileron extending between said center line and opposite side edge of the hull;

control means for raising and lowering said ailerons and means connecting said control means to each of said ailerons;

said control means being movably mounted upon said hull and being movable in one direction to simultaneously raise one aileron and lower the other and movably in an opposite direction to reversely move said ailerons;

force transmitting means interconnecting the sail and said control means for moving said control means in response to the direction and amount of force applied to said sail, wherein said control means moves in response to such force to thereby move said ailerons in directions to counteract and counterbalance the force upon the sail;

said control means comprising a rotatable drum, and said means for connecting said control means to said ailerons comprising stiff rods, each connected at one end to the drum and at opposite ends to one aileron with the connection to the drum being at opposite sides of the drum axis so that rotation of the drum in one direction raises one rod and lowers the other to thereby move the ailerons in opposite directions;

said drum being movable upwardly and downwardly for thereby moving both ailerons simultaneously upwardly and downwardly for adjusting the ailerons into a substantial lift providing position while the hull is in the water for assisting the hydrofoil in lifting the hull out of the water for sailing only upon the hydrofoil;

and spring means connected to said drum for holding the drum in a position wherein both ailerons normally are in a lift providing position, but said spring means being of a predetermined value to be overcome by a predetermined water pressure upon said ailerons calibrated at approximately the speed where the hull leaves the water, for returning the drum, under pressure applied to the ailerons, to a position where it no longer moves the ailerons to a substantial lift providing position.

3. A construction as defined in claim 2, and said force transmitting means comprising shrouds connected at one end to the opposite sides of the mast and at their opposite ends to a means for rotating said drum in response to tautening of one or the other of said shrouds.

4. A construction as defined in claim 3, and said means for rotating said drum comprising a pulley mounted on said hull and connected to said drum by a belt with the shrouds connected to said belt.

5. A sailboat comprising a hull having a mast upon which a sail is secured, and a hydrofoil secured to and mounted beneath and transversely of said hull; said hydrofoil including a pair of ailerons movably fastened thereto for upwardly and downwardly move-

ment relative thereto, with one aileron extending from the center line of the hull and towards one side edge thereof and the other aileron extending between said center line and opposite side edge of the hull; control means for raising and lowering said ailerons and means connecting said control means to each of said ailerons;

said control means being movably mounted upon said hull and being movable in one direction to simultaneously raise one aileron and lower the other and movable in an opposite direction to reversely move said ailerons;

force transmitting means comprising shrouds connected to each side of the mast and extending to and connected to said control means for moving said control means in response to the direction and amount of force applied to said mast from the sail, wherein said control means automatically moves in response to such force to thereby move said ailerons in directions to counteract and counterbalance the force upon the sail.

References Cited

UNITED STATES PATENTS

2,703,063	3/1955	Gilruth	114—66.5
2,858,788	11/1958	Lyman	114—39
3,099,976	8/1963	Schwaneke et al.	114—91

MILTON BUCHLER, *Primary Examiner.*

T. M. BLIX, *Assistant Examiner.*